

GATE

Civil Engineering

(Previous Years Solved Papers 1990-1994)

Contents

1. Solid Mechanics	2
2. Structural Analysis	9
3. RCC Structures and Prestressed Concrete	17
4. Design of Steel Structures	22
5. Geotechnical Engineering	26
6. Fluid Mechanics & Fluid Machines	35
7. Environmental Engineering	42
8. Irrigation Engineering	50
9. Engineering Hydrology	54
10. Transportation Engineering	57
11. Geometrics Engineering	63
12. Engineering Mathematics	68



Solid Mechanics

UNIT

I

CONTENTS

1. Properties of Metals, Stress & Strain 3
2. Shear Force and Bending Moment 3
3. Principal Stress and Principal Strain 3
4. Bending and Shear Stresses 4
5. Deflection of Beams 4
6. Torsion of Shafts and Pressure Vessels 4
7. Theory of Columns & Shear Centre 4

Solid Mechanics

1. Properties of Metals, Stress & Strain

- 1.1 The maximum value of Poisson's ratio for an elastic material is
- (a) 0.25 (b) 0.5
(c) 0.75 (d) 0.1

[1991 : 1 Mark]

- 1.2 A cantilever beam of tubular section consists of two materials, copper as outer cylinder and steel as inner cylinder. It is subjected to a temperature rise of 20°C and $\alpha_{\text{copper}} > \alpha_{\text{steel}}$. The stresses developed in the tubes will be
- (a) compression in steel and tension in copper
(b) tension in steel and compression in copper
(c) no stress in both
(d) tension in both the materials

[1991 : 1 Mark]

2. Shear Force and Bending Moment

- 2.1 A beam having a double cantilever attached at mid span is shown in the figure. The nature of force in beam 'ab' is

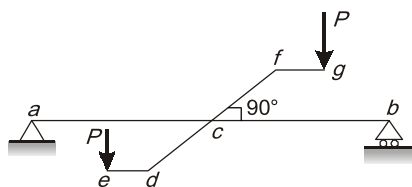

Lengths $cd = cf$, $de = fg$, $ac = cb$

- (a) Bending and shear
(b) Bending, shear and torsion
(c) Pure torsion
(d) Torsion and shear

[1991 : 1 Mark]

- 2.2 A cantilever beam curved in plane is subjected to lateral loads will develop at any section
- (a) bending moment and shearing force.
(b) bending moment and twisting moment.
(c) twisting moment and shearing force.
(d) bending moment, twisting moment and shearing force.

[1994 : 1 Mark]

3. Principal Stress and Principal Strain

- 3.1 A failure theory postulated for metals is shown in a two dimensional stress plane. The theory is called

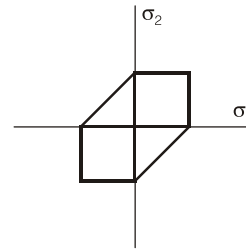

- (a) Maximum distortion energy theory
(b) Maximum normal stress theory
(c) Maximum shear stress theory
(d) Maximum strain theory

[1991 : 1 Mark]

- 3.2 Which of the following Mohr's circles qualitatively correctly represents the state of plane stress at a point in a beam above the neutral axis, where it is subjected to combined shear and bending compressive stresses?

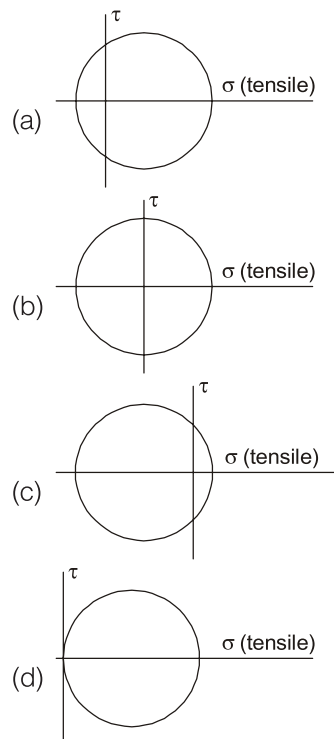

[1993 : 1 Mark]

4. Bending and Shear Stresses

- 4.1 For a given shear force across a symmetrical 'I' section, the intensity of shear stress is maximum at the
- extreme fibres
 - centroid of the section
 - at the junction of the flange and the web, but on the web
 - at the junction of the flange and the web, but on the flange

[1991, 1994 : 1 Mark]

- 4.2 The maximum bending stress induced in a steel wire of modulus of elasticity 200 kN/mm^2 and diameter 1 mm when wound on a drum of diameter 1 m is approximately equal to
- 50 N/mm^2
 - 100 N/mm^2
 - 200 N/mm^2
 - 400 N/mm^2

[1992 : 1 Mark]

5. Deflection of Beams

- 5.1 A cantilever beam of span L is subjected to a downward load of 800 kN uniformly distributed over its length and a concentrated upward load P , at its free end. For vertical displacement to be zero at the free end, the value of P is
- 300 kN
 - 500 kN
 - 800 kN
 - 1000 kN

[1992 : 2 Marks]

- 5.2 In a real beam, at an end, the boundary condition of zero slope and zero vertical displacement exists. In the corresponding conjugate beam, the boundary conditions at this end will be
- shear force = 0 and bending moment = 0
 - slope = 0 and vertical displacement = 0
 - slope = 0 and bending moment = 0
 - shear force = 0, and vertical displacement = 0

[1992 : 1 Mark]

- 5.3 A simply supported beam of span length L and flexural stiffness EI has another spring support at the centre of stiffness K as shown in figure. The central deflection of the beam due to a central concentrated load of P would be

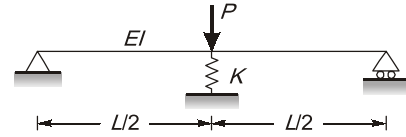

- $\frac{PL^3}{48EI + KL^3}$
- $\frac{P}{(48EI/L^3) - K}$
- $\left(\frac{PL^3}{48EI}\right)\left(\frac{P}{K}\right)$
- $\frac{P}{48EI/L^3} + K$

[1993 : 2 Marks]

- 5.4 A cantilever beam of span l subjected to uniformly distributed load w per unit length resting on a rigid prop at the tip of the cantilever. The magnitude of the reaction at the prop is

- $\frac{1}{8}wl$
- $\frac{2}{8}wl$
- $\frac{3}{8}wl$
- $\frac{4}{8}wl$

[1994 : 2 Marks]

6. Torsion of Shafts and Pressure Vessels

- 6.1 A thin cylindrical vessel of mean diameter D and of length ' L ' closed at both the ends is subjected to a water pressure ' p '. The value of hoop stress and longitudinal stress in the shell shall be respectively

- $\frac{pD}{2t}, \frac{pD}{4t}$
- $\frac{pD}{4t}, \frac{pD}{8t}$
- $\frac{pD}{8t}, \frac{pD}{8t}$
- $\frac{pD}{t}, \frac{pD}{2t}$

[1991 : 2 Marks]

7. Theory of Columns & Shear Centre

- 7.1 The kern area (core) of a solid circular section column of diameter, D , is a concentric circle of diameter, d , equal to

- $\frac{D}{8}$
- $\frac{D}{6}$
- $\frac{D}{4}$
- $\frac{D}{2}$

[1992 : 2 Marks]

- 7.2 The axial load carrying capacity of a long column of given material, cross-sectional area, A , and length, L , is governed by
- (a) strength of its material only
 - (b) its flexural rigidity only
 - (c) its slenderness ratio only
 - (d) both flexural rigidity and slenderness ratio

[1992 : 1 Mark]

- 7.3 When a column is fixed at both ends, corresponding Euler's critical load is

- (a) $\frac{\pi^2 EI}{L^2}$
- (b) $\frac{2\pi^2 EI}{L^2}$
- (c) $\frac{3\pi^2 EI}{L^2}$
- (d) $\frac{4\pi^2 EI}{L^2}$

Where L is the length of the column.

[1994 : 2 Marks]



Answers Solid Mechanics

- 1.1 (b) 1.2 (b) 2.1 (a) 2.2 (d) 3.1 (c) 3.2 (c) 4.1 (b) 4.2 (c) 5.1 (a)
 5.2 (a) 5.3 (a) 5.4 (c) 6.1 (a) 7.1 (c) 7.2 (d) 7.3 (d)

Explanations Solid Mechanics

1. Properties of Metals, Stress & Strain

1.1 (b)

The range of Poisson's ratio (μ) is,
 $0 \leq \mu \leq 0.5$

1.2 (b)

Method-I

The magnitude of extension in the beam due to change in temperature is $L\alpha T$.

where, L = length of the beam

α = coefficient of thermal expansion

T = change in temperature

as $\alpha_{\text{copper}} > \alpha_{\text{steel}}$

$\therefore (\Delta l)_{\text{copper}} > (\Delta l)_{\text{steel}}$

As free extension in copper is more than steel, so equilibrium will develop compressive stress in copper and will develop tensile stress in steel.

Note: As it is not given whether the two material form a composite section or not, so we will treat them to be connected together.

Method-II

If assumed connected:

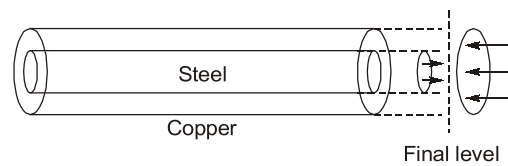

If assumed independent free expansion:

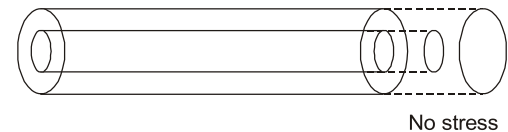

2. Shear Force and Bending Moment

2.1 (a)

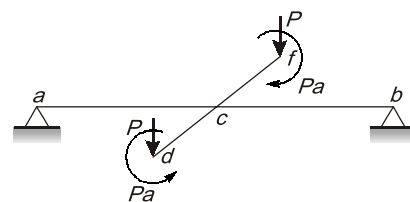

Now we transfer the load at point C , hence net force transferred is $2P$ but moments will get cancelled.

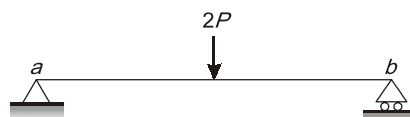

This loading can cause only bending and shear.

2.2 (d)

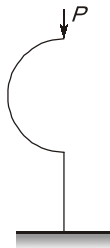

Cantilever arc \rightarrow in x - y plane
 Load ' P ' \rightarrow along z - z axis
 So bending, twisting moment and shearing force.

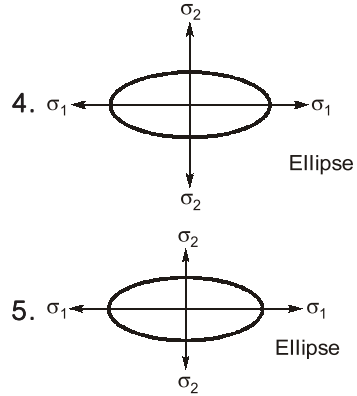

3. Principal Stress and Principal Strain

3.1 (c)

Theory

1. Maximum principal stress theory
2. Maximum principal strain theory
3. Maximum shear stress theory
4. Maximum strain energy theory
5. Maximum shear strain energy theory/
Distortion energy theory/Mises-Henky theory

Two dimensional stress plane

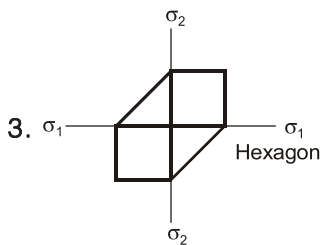
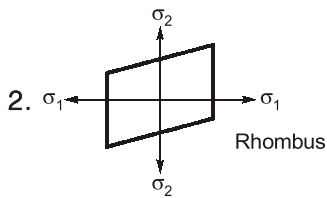
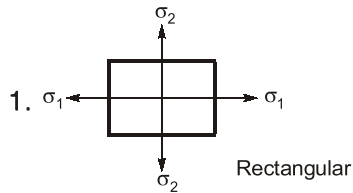

3.2 (c)

Let ' A ' be a point in a beam above the neutral axis.

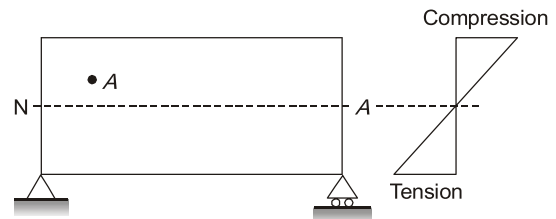

Plane stress diagram of point ' A '

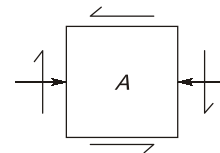

Mohr circle will be best represent as,

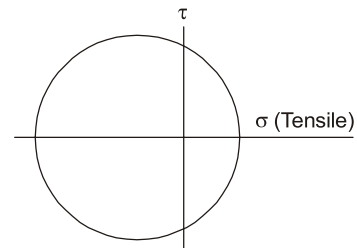

4. Bending and Shear Stresses

4.1 (b)

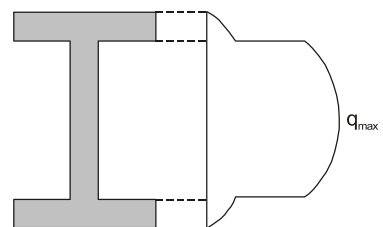

Shear stress diagram

The intensity of shear stress is maximum at centroid of the section = $\frac{3}{2} \tau_{avg}$.

4.2 (c)

As we know,

$$\frac{M}{I} = \frac{E}{R} = \frac{f}{y}$$

$$E = 200 \text{ kN/mm}^2 = 2 \times 10^5 \text{ N/mm}^2$$

$$\therefore f = \frac{Ey}{R} = \frac{2 \times 10^5}{500} \times 0.5 = 200 \text{ N/mm}^2$$

5. Deflection of Beams

5.1 (a)

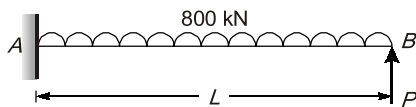

For the vertical displacement to be zero at the free end, the vertical downward displacement due to UDL should be equal to upward displacement due to load P.

$$\therefore \frac{wL^4}{8EI} = \frac{PL^3}{3EI}$$

$$\Rightarrow P = \frac{3}{8}wL = \frac{3}{8} \times 800 = 300 \text{ kN}$$

5.2 (a)

The end conditions in a conjugate beam will be such that if a real beam at a support has non zero slope or deflection, the conjugate beam will have non zero SF or BM respectively.

Slope = 0, SF = 0
 Deflection = 0, BM = 0

5.3 (a)

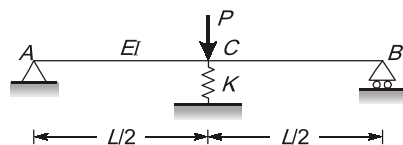

Let reaction due to the spring be R
 Now,

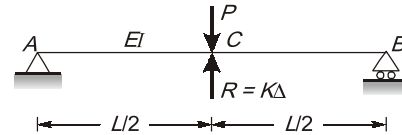

By compatibility condition

$$\therefore \frac{PL^3}{48EI} - \frac{RL^3}{48EI} = \Delta_{\text{spring}}$$

$$\Rightarrow \frac{PL^3}{48EI} - \frac{RL^3}{48EI} = \frac{R}{K}$$

$$\Rightarrow R \left(\frac{1}{K} + \frac{L^3}{48EI} \right) = \frac{PL^3}{48EI}$$

$$\Rightarrow R \left(\frac{48EI + KL^3}{48EIK} \right) = \frac{PL^3}{48EI}$$

$$R = \frac{PL^3K}{48EI + KL^3}$$

$$\therefore \Delta_{\text{spring}} = \frac{R}{K} = \frac{PL^3}{48EI + KL^3}$$

5.4 (c)

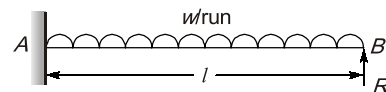

Let R is the prop-reaction at the tip of a cantilever beam.

\therefore Deflection at B = 0

$$\Rightarrow \frac{wl^4}{8EI} - \frac{Rl^3}{3EI} = 0$$

$$\Rightarrow R = \frac{3}{8}wl$$

6. Torsion of Shafts and Pressure Vessels

6.1 (a)

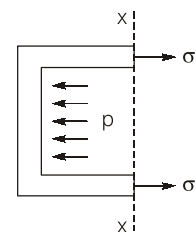

Longitudinal stress, $\sigma_L = \frac{pD}{4t}$

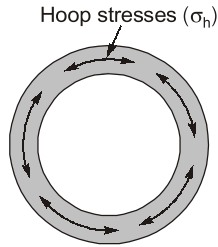

$$\text{Hoop stress, } \sigma_h = \frac{pD}{2t}$$

7. Theory of Columns & Shear Centre

7.1 (c)

Kern of a column is that area through which if resultant load passes then there will be no resultant tension anywhere on the section of column.

For a solid circular column section, kern is also a circular section with diameter of kern, $d = \frac{D}{4}$ and maximum eccentricity = $\frac{D}{8}$.

7.2 (d)

$$\therefore P_{cr} = \frac{\pi^2 EI}{L^2}$$

$$\Rightarrow P_{cr} = \frac{\pi^2 EA r_{\min}^2}{L^2}$$

$$\Rightarrow P_{cr} = \frac{\pi^2 EA}{\lambda^2}$$

\therefore The axial load carrying capacity of long column depends on both slenderness ratio and flexural rigidity.

7.3 (d)

$$\text{Eulers critical load, } P_c = \frac{\pi^2 EI}{l_{\text{eff}}^2}$$

If both end of a column is fixed as shown in figure,

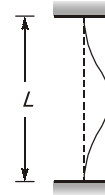

$$\text{Then, } l_{\text{eff}} = L/2$$

$$\therefore P_c = \frac{4\pi^2 EI}{L^2}$$



Structural Analysis

UNIT

II

CONTENTS

1. Determinacy and Indeterminacy 10
2. Influence Line Diagram and Rolling Loads 10
3. Methods of Structural Analysis 11
4. Matrix Method of Structural Analysis 11

Structural Analysis

1. Determinacy and Indeterminacy

1.1 The beam supported by 3 links and loaded as shown in the figure is

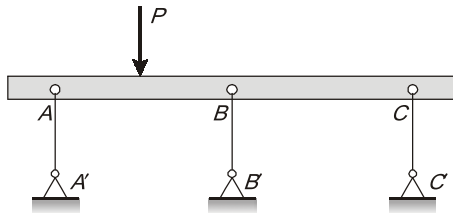

- (a) stable and determinate
- (b) unstable
- (c) stable and indeterminate
- (d) unstable but determinate

[1991 : 1 Mark]

1.2 A plane structure shown in the figure is

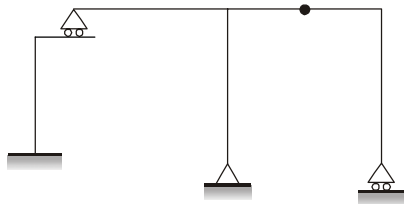

- (a) stable and determinate
- (b) stable and indeterminate
- (c) unstable and determinate
- (d) unstable and indeterminate

[1992 : 1 Mark]

1.3 A plane frame $ABCDEFGH$ shown in figure has clamp support at A , hinge supports at G and H , axial force release (horizontal sleeve) at C and moment release (hinge) at E . The static (D_s) and kinematic (D_k) indeterminacies are

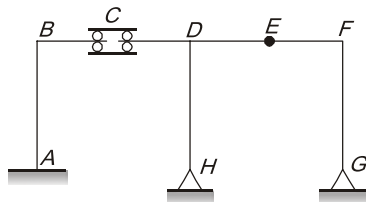

- | | D_s | D_k |
|-----|-------|-------|
| (a) | 4 | 9 |
| (b) | 3 | 11 |
| (c) | 2 | 12 |
| (d) | 1 | 14 |

[1992 : 2 Marks]

1.4 The plane frame shown in figure is

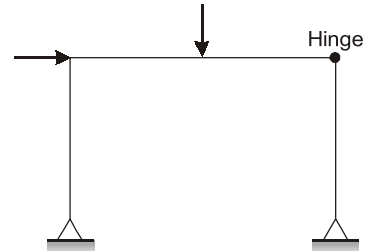

- (a) stable and statically determinate
- (b) unstable and statically determinate
- (c) stable and statically indeterminate
- (d) unstable and statically indeterminate

[1993 : 2 Marks]

1.5 The kinematic indeterminacy of the plane frame shown in figure is (disregarding the axial deformation of the members)

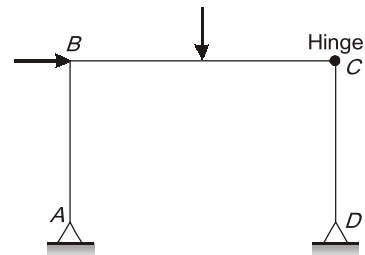

- (a) 7
- (b) 5
- (c) 6
- (d) 4

[1993 : 1 Mark]

1.6 The kinematic indeterminacy of single bay portal frame fixed at the base is

- (a) One
- (b) Two
- (c) Three
- (d) Zero

[1994 : 1 Mark]

1.7 A beam fixed at the ends and subjected to lateral loads only is statically indeterminate and the degree of indeterminacy is

- (a) One
- (b) Two
- (c) Three
- (d) Four

[1994 : 1 Mark]

2. Influence Line Diagram and Rolling Loads

2.1 Influence line for redundant structures can be obtained by

- (a) Castigliano's theorem
- (b) Muller Breslau principle

- (c) Unit load theorem
- (d) Maxwell-Betti's reciprocal theorem

[1994 : 1 Mark]

3. Methods of Structural Analysis

3.1 The moments at the ends *A* and *B* of a beam *AB* where end *A* is fixed and *B* is hinged, when the end *B* sinks by an amount Δ , are given as

- (a) $\frac{6EI\Delta}{l^2}, \frac{6EI\Delta}{l^2}$ (b) $\frac{6EI\Delta}{l^2}, 0$
- (c) $\frac{3EI\Delta}{l^2}, \frac{3EI\Delta}{l^2}$ (d) $\frac{3EI\Delta}{l^2}, 0$

[1991 : 1 Mark]

3.2 A cantilever beam of span *L* is subjected to a load *W* at a distance 'a' from support. It is desired to obtain the vertical displacement at the free end by unit load method. The expression for deflection is

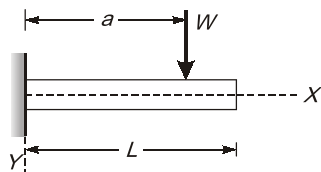

- (a) $y = \int_0^a \frac{W(a-x)(a-x)}{EI} dx$
- (b) $y = \int_0^a \frac{W(a-x)(L-x)}{EI} dx$
- (c) $y = \int_0^a \frac{W(x-a)(L-x)}{EI} dx$
- (d) $y = \int_0^a \frac{W(L-x)(L-x)}{EI} dx$

[1992 : 2 Marks]

3.3 Methods of indeterminate structural analysis may be grouped under either force method or displacement method. Which of the groupings given below is correct?

Group-I (Force Method)	Group-II (Displacement Method)
(a) Moment distribution method Consistent deformation method	1. Method of three moments Slope deflection method
(b) Method of three moments Consistent deformation method	2. Moment distribution method Slope deflection method
(c) Slope deflection method Consistent deformation method	3. Moment distribution method Method of three moment
(d) Moment distribution method Method of three moments	4. Slope deflection method Consistent deformation method

[1993 : 2 Marks]

3.4 The fixed end moment of uniform beam of span *l* and fixed at the ends, subjected to a central point load *P* is

- (a) $\frac{Pl}{2}$ (b) $\frac{Pl}{8}$
- (c) $\frac{Pl}{12}$ (d) $\frac{Pl}{16}$

[1994 : 2 Marks]

3.5 A single bay portal frame of height *h* fixed at the base is subjected to horizontal displacement Δ at the top. The base moments developed is proportional to

- (a) $\frac{1}{h}$ (b) $\frac{1}{h^2}$
- (c) $\frac{1}{h^3}$ (d) None of these

Consider all members are prismatic.

[1994 : 2 Marks]

3.6 Match the following methods with appropriate analysis

- (a) Strain energy method
- (b) Complementary energy method
- (c) Muller Breslau Principle
- (d) Kani's method of analysis
- (i) Influence for redundant structures
- (ii) Deflection of linear structures
- (iii) Deflection of non-linear structures
- (iv) Analysis of multistoreyed frames

[1994 : 2 Marks]

4. Matrix Method of Structural Analysis

4.1 In a linear elastic structural element

- (a) stiffness is directly proportional to flexibility
- (b) stiffness is inversely proportional to flexibility
- (c) stiffness is equal to flexibility
- (d) stiffness and flexibility are not related

[1991 : 1 Mark]

4.2 The ratio of the stiffness of a beam at the near end when the far end is hinged to the stiffness of the beam at the near end when the far end is fixed is

- (a) 1/2 (b) 3/4
- (c) 1 (d) 4/3

[1994 : 2 Marks]

4.3 In a linear structural element
 (a) stiffness is directly proportional to flexibility
 (b) stiffness is inversely proportional to flexibility
 (c) stiffness is equal to flexibility
 (d) stiffness and flexibility are not related
 [1994 : 1 Mark]

4.5 Flexibility of structure may be defined as the displacement caused for.....force and stiffness of structure may be defined as the force caused for.....displacement
 [1994 : 1 Mark]

4.4 In flexibility method, the unknown quantities are whereas in stiffness method the unknown quantities are.....
 [1994 : 1 Mark]

Answers Structural Analysis

- 1.1 (c) 1.2 (a) 1.3 (c) 1.4 (a) 1.5 (d) 1.6 (c) 1.7 (b) 2.1 (b) 3.1 (d)
 3.2 (b) 3.3 (b) 3.4 (b) 3.5 (b) 3.6 (*) 4.1 (b) 4.2 (b) 4.3 (b) 4.4 (Sol.)
 4.5 (Sol.)

Explanations Structural Analysis

1. Determinacy and Indeterminacy

1.1 (c)

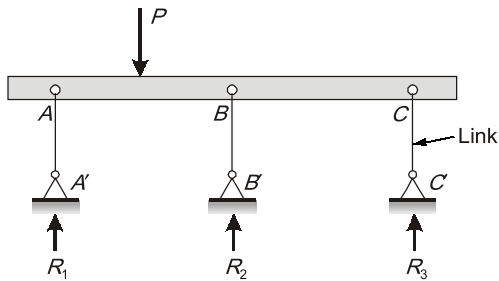

$$D_{se} = 3 - 2 = 1$$

$$\sum F_y = 0 \text{ \& } \sum M = 0$$

$$D_{si} = 0$$

$$\therefore D_s = 1$$

(Indeterminate of degree 1)

Note : Link will carry only axial force (AA', BB', CC')

FBD :

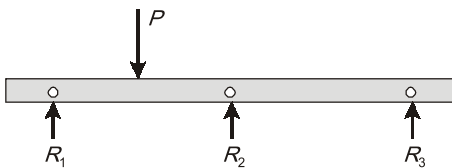

All reactions are parallel, but the structure is stable only for vertical loading.

Note : For general loading the structure is unstable.

1.2 (a)

Method-I (By Formula)

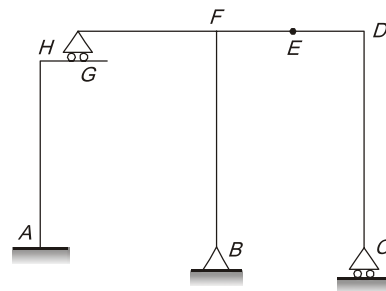

Static determinacy

$$D_s = 3m + r_e - 3j - r_r$$

$$= (3 \times 7) + (3 + 2 + 1) - (3 \times 8)$$

$$- [1 \text{ (at E)} + 2 \text{ (at G)}]$$

$$= 0$$

⇒ The structure is stable and determinate.

Method-II (By Cantilever Method)

$$D_s = 3C - R$$

Where 'R' is the number of release in a structure

$$= 3 \times 2 - [1 \text{ (at B)} + 2 \text{ (at C)}$$

$$+ 1 \text{ (at E)} + 2 \text{ (at G)}]$$

$$= 0$$



POINTS TO REMEMBER

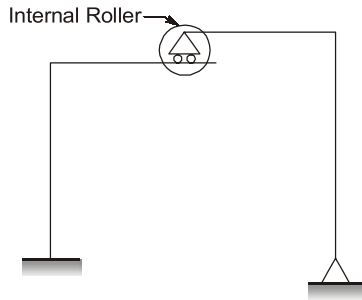

Two internal forces are released at internal roller (bending moment and axial force)
 $R = 2$

1.3 (c)

Method-I (By Cantilever method)

Degree of static indeterminacy,

$$D_s = 3C - R$$

$$D_s = 3 \times 2 - 1 \text{ (at H)} - 1 \text{ (at G)}$$

$$- 1 \text{ (at E)} - 1 \text{ (at C)}$$

$$D_s = 2$$

(D_k by simple counting of DOF's of joint)

Degree of kinematic indeterminacy,

$$D_k = 3 \text{ (at B)} + 3 \text{ (at D)} + 3 \text{ (at F)}$$

$$+ 1 \text{ (at H)} + 1 \text{ (at G)} + 4 \text{ (at C)}$$

$$+ 4 \text{ (at E)}$$

$$D_k = 19$$

If members are considered **inextensible**, then
 $D_k = 19 - \text{Number of inextensible members}$
 $\therefore D_k = 19 - 7 = 12$

Hence best possible option is (c)

Method-II (By Formula)

Static indeterminacy,

$$D_s = 3m + r_e - 3j - r_r$$

$$= (3 \times 7) + (3 + 2 + 2) - (3 \times 8)$$

$$- [1 \text{ (at C)} + 1 \text{ (at E)}] = 2$$

Kinematic indeterminacy,

$$D_k = 3j - r_e - m'' + r_r$$

Considering all the member are rigid, $m'' = 7$

$$D_k = (3 \times 8) - (3 + 2 + 2) - 7$$

$$+ [1 \text{ (at C)} + 1 \text{ (at E)}]$$

$$= 12$$

1.4 (a)

Method-I (By Formula)

The degree of static indeterminacy, D_s is given by,

$$D_s = 3m + r_e - 3j - r_r$$

Where, m = number of members = 3

r_e = number of external reactions = 4

j = number of joints = 4

r_r = total member of internal reactions released due to the presence of hybrid joints = $\Sigma(m^i - 1)$

m^i = number of members meeting at a joint

$$\therefore r_r = 2 - 1 = 1$$

$$\Rightarrow D_s = 3 \times 3 + 4 - 3 \times 4 - 1 = 0$$

\therefore The frame is **stable** and **statically determinate**.

Method-II (By Cantilever method)

$$D_s = 3C - R$$

$$= 3 \times 1 - [1 \text{ (at A)} + 1 \text{ (at C)}$$

$$+ 1 \text{ (at D)}]$$

$$= 0$$

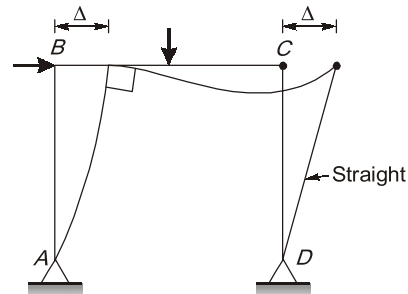

Hence, the structure is stable and determinate. Stability can be established by visual inspection.

1.5 (d)

Total DoF = ($\theta_A, \theta_D, \theta_B, \theta_{CB}, \theta_{CD}, \Delta_{xB}$)

But for the given loading, the elastic curve can be represented as,

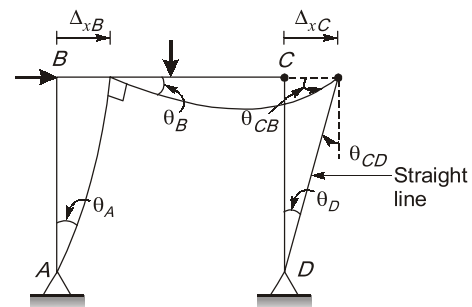

Kinematic indeterminacy = 4 ($\theta_A, \theta_B, \Delta_{xB}, \theta_{CB}$) because others displacements are dependent on Δ_{xB} .

$$\Delta_{xC} = \Delta_{xB}$$

$$\theta_{CD} = \theta_D = \frac{\Delta_{xC}}{L} = \frac{\Delta_{xB}}{L}$$

1.6 (c)

The degree of **kinematic indeterminacy** is given by,

$$D_k = 3j - r_e - m'' + r_r$$

Where, j = number of joints = 4

r_e = number of external reactions = 6

m'' = number of rigid members = 3

r_r = total member of internal reactions released due to the presence of hybrid joints = $\Sigma(m' - 1) = 0$

$$\therefore D_k = 3 \times 4 - 6 - 3 + 0 = 12 - 6 - 3 = 3$$

Note:

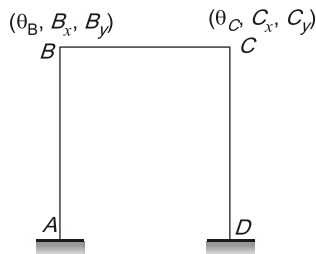

AB Rigid $B_y = 0$
 CD Rigid $C_y = 0$
 BC Rigid $B_x = C_x = \Delta$

$$\therefore \text{Total independent } D_K = 3 (\theta_B, \theta_C, \Delta)$$

1.7 (b)

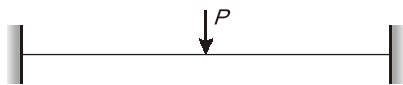

The degree of external indeterminacy is given by,

$$D_{se} = r_e - \text{no. of available equilibrium equations.}$$

Where, r_e = number of external reactions = 4

($\because H = 0$ as the beam carries only lateral loads)

No of available equations = 2 ($\Sigma F_y = 0, \Sigma M = 0$)

$$\therefore D_{se} = 4 - 2 = 2$$

Internal indeterminacy = 0

Note : (Beam are always internally determinate)

\therefore Total degree of **static indeterminacy**,

$$D_s = D_{se} + D_{si}$$

$$= 2 + 0 = 2$$



AVOID MISTAKE

$$D_s = r_e - 3 = (3 + 3) - 3 = 3$$

As only lateral loads are acting on the beam, horizontal reactions and $\Sigma H = 0$ equation will not be considered.

2. Influence Line Diagram and Rolling Loads

2.1 (b)

Muller Breslau principle is used to determine influence line for redundant structures whereas other three methods in option (a), (c) and (d) are useful for determining deflection in the structure.



POINTS TO REMEMBER

The muller-Breslau principle is a method to determine influence lines. The principle states that the influence lines of an action (force or moment) assumes the scaled form of the deflection or displacement.

This principle also states that "ordinate of ILD for a reactive force is given by ordinate of elastic curve if a unit deflection is applied in the direction reactive force."

3. Methods of Structural Analysis

3.1 (d)

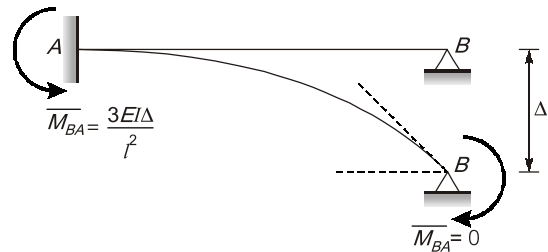

3.2 (b)

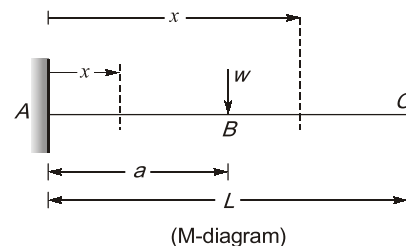

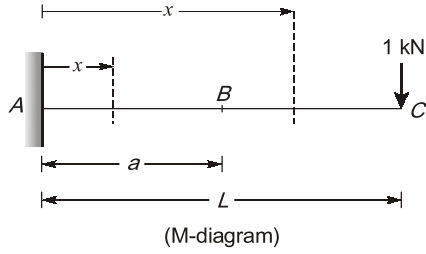

	M	m	Limit of x
AB	$-W(a-x)$	$-(L-x)$	0 to a
BC	0	$-(L-x)$	a to L

Vertical displacement at free end,

$$\delta_v = \int \frac{Mm dx}{EI}$$

$$= \int_0^a \frac{W(a-x)(L-x)}{EI} dx$$

In conjugate beam slope = SF, deflection = BM.

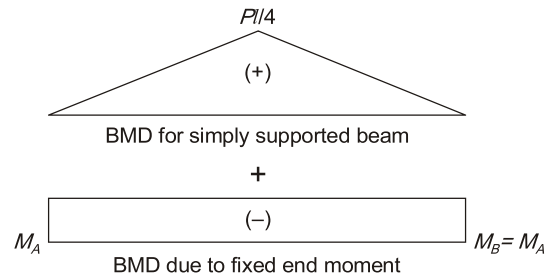

Using moment area method,

$\delta_{B/A}$ = deflection of point B w.r.t. tangent at A = 0

$$\Rightarrow \left(\frac{1}{2} \times \frac{Pl}{4} \times l \times \frac{l}{2} \right) - \left(M_A \times l \times \frac{l}{2} \right) = 0$$

$$\Rightarrow M_A = \frac{Pl}{8}$$

3.3 (b)

Force methods are:

- (i) Unit load method
- (ii) Virtual work method
- (iii) Clapeyron's three moment theorem
- (iv) Column analogy method
- (v) Castigliano's theorem
- (vi) Minimum potential energy method
- (vii) Flexibility matrix method

Displacement methods are:

- (i) Moment distribution
- (ii) Slope deflection
- (iii) Kani's method
- (iv) Stiffness matrix method

3.4 (b)

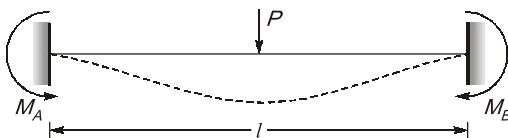

M_A, M_B : Fixed end moments at support A and B.
As the loading is symmetrical $M_A = M_B$

3.5 (b)

As per statement the portal frame is as shown in fig.

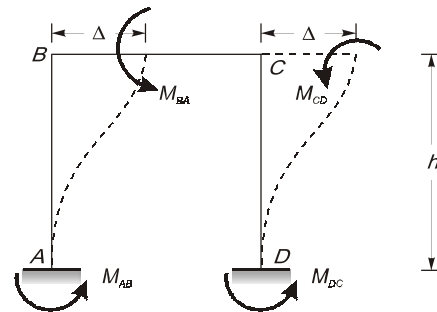

$$M_{AB} = M_{BA} = M_{CD} = M_{DC} = \frac{6EI\Delta}{h^2}$$

\therefore Base moment developed $\propto \frac{1}{h^2}$

3.6 (*)

- (a) **Strain energy method** : (ii) and (iii) Deflection of both non-linear and linear structures.
- (b) **Complementary energy method** : (ii) and (iii) Deflection of non-linear structures and linear structures.
- (c) **Muller Breslau principle** : (i) Influence for redundant structures
- (d) **Kani's method of analysis** : (iv) Analysis of multistoreyed frames.

4. Matrix Method of Structural Analysis**4.1 (b)**

Stiffness is defined as the force/moment required to produce unit deflection/unit rotation.

Flexibility is defined as the displacement/rotation required to produce unit force/unit moment.

4.2 (b)

Stiffness of the beam at near end, when far end

hinged is $\frac{3EI}{l}$

Stiffness of the beam at near end, when far end

fixed is $\frac{4EI}{l}$

$$\therefore \text{required ratio} = \frac{3EI/l}{4EI/l} = \frac{3}{4}$$

4.4 Sol.

Force/Moment, Deflection/Rotation

4.5 Sol.

Unit, Unit



RCC Structures and Prestressed Concrete

UNIT III

CONTENTS

1. Working Stress & Limit State Method 18
3. Footing, Columns, Beams and Slabs 18
4. Prestressed Concrete 19

RCC Structures and Prestressed Concrete

1. Working Stress & Limit State Method

1.1 The total compressive force at the time of failure of a concrete beam section of width 'b' without considering the partial safety factor of the material is

- (a) $0.36 f_{ck} b X_u$ (b) $0.54 f_{ck} b X_u$
 (c) $0.66 f_{ck} b X_u$ (d) $0.8 f_{ck} b X_u$

Where, X_u is depth of neutral axis,
 f_{ck} is cube strength of concrete.

[1991 : 2 Marks]

1.2 A floor slab of thickness, t , is cast monolithically transverse to a rectangular continuous beam of span, L , and width, B . If the distance between two consecutive points of contraflexure is, L_0 , the effective width of compression flange at a continuous support is

- (a) B (b) $L/3$
 (c) $B + 12t$ (d) $B + 6t + L_0/6$

[1992 : 1 Mark]

1.3 A reinforced concrete member is subjected to combined action of compressive axial force and bending moment. If ϵ_c is the least compressive strain in the member, f_y the yield stress of steel and, E_s , the modulus of elasticity of steel, the maximum permissible compressive strain in concrete member will be

- (a) 0.002
 (b) $0.002 + f_y / (1.15 E_s)$
 (c) $0.0035 - 0.75 \epsilon_c$
 (d) 0.0035

[1992 : 1 Mark]

1.4 The factored loads at the limit state of collapse for DL + LL, DL + WL and DL + LL + WL combinations, according to IS 456 : 1978 are respectively.

- (a) 1.5 DL + 1.5 LL, 1.2 DL + 1.2 WL, 1.5 DL + 1.5 LL + 1.5 WL
 (b) (0.9 or 1.5) DL + 1.5 LL, 1.5 DL + 1.5 WL, 1.2 DL + 1.2 LL + 1.2 WL
 (c) 1.2 DL + 1.2 LL, 1.5 DL + 1.5 WL, 1.5 DL + 1.5 LL + 1.5 WL
 (d) 1.5 DL + 1.5 LL, (0.9 or 1.5) DL + 1.5 WL, 1.2 DL + 1.2 LL + 1.2 WL

[1993 : 1 Mark]

2. Footing, Columns, Beams and Slabs

2.1 Axial load carrying capacity of a RC column of gross area of concrete A_c , area of steel A_s , and permissible stresses σ_c in concrete and σ_s in steel, m-modular ratio is given as

- (a) $\sigma_c A_c + (m - 1) \sigma_c A_s$
 (b) $\sigma_s A_s + m \sigma_c A_s$
 (c) $\sigma_c A_s + \sigma_c A_s$
 (d) $\sigma_c (A_c - A_s) + \sigma_c A_s$

[1991 : 1 Mark]

2.2 (i) Interaction diagram of a rectangular reinforced concrete beam column is shown in the figure. With reference to this figure, which of the following statements in (i) and (ii) below are correct?

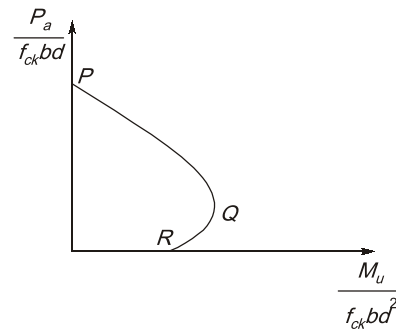

- (a) Point Q represents balanced failure
 (b) Point R represents balanced failure
 (c) Point P represents balanced failure
 (d) Point Q represents balanced failure under maximum eccentric compression

- (ii) (a) PQ corresponds to the primary tension failure range
 (b) QR corresponds to the primary tension failure range
 (c) QR corresponds to the primary compression failure range
 (d) PQ corresponds to the range of increase in axial force capacity with increase in bending moment capacity

[1993 : 2 Marks]

3. Prestressed Concrete

3.1 A prestressed concrete beam has a cross-section with the following properties:

Area $A = 46,400 \text{ mm}^2$

$I = 75.8 \times 10^7 \text{ mm}^4$

$y_{\text{bottom}} = 244 \text{ mm}, y_{\text{top}} = 156 \text{ mm}$

It is subjected to a prestressing force at an eccentricity 'e' so as to have a zero stress at the top fibre. The value of 'e' is given by

- (a) 66.66 mm
- (b) 66.95 mm
- (c) 104.72 mm
- (d) 133.33 mm

[1991 : 2 Marks]

3.2 The loss of prestress due to elastic shortening of concrete is least in

- (a) one wire pre-tensioned beam
- (b) one wire post-tensioned beam
- (c) multiple wire pre-tensioned beam with sequential cutting of wires
- (d) multiple wire post-tensioned beam subjected to sequential prestressing

[1992 : 1 Mark]

3.3 A uniformly distributed load intensity, w , acting on a simply supported prestressed concrete beam of span, L , producing a bending moment, M , at mid-span is to be balanced by a parabolic tendon with zero eccentricity at ends and eccentricity, e , at mid-span. The prestressing force required depends on

- (a) w and e
- (b) w and L
- (c) L and e
- (d) M and e

[1992 : 1 Mark]



Answers RCC Structures and Prestressed Concrete

- 1.1 (b) 1.2 (a) 1.3 (c) 1.4 (d) 2.1 (a) 2.2 (i) (a), (ii) (b) 3.1 (c) 3.2 (b)
 3.3 (d)

Explanations RCC Structures and Prestressed Concrete

1. Working Stress & Limit State Method

1.1 (b)

According to IS : 456, Clause No. 38.1.C The relationship between the compressive stress distribution in concrete and the strain in concrete may be assumed to be rectangle, trapezoid, parabola or any other shape which results in prediction of strength in substantial agreement with the results of test. An acceptable stress-strain diagram is given below:

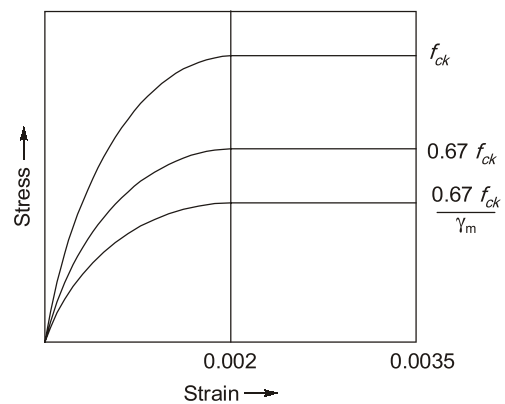

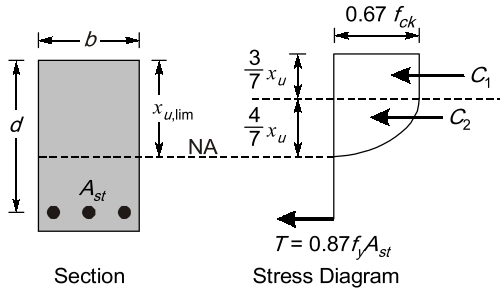

Total compressive force =
 (Area of stress block × width)

$$= \left(0.67 f_{ck} \cdot \frac{3}{7} X_u \right) b + \left(\frac{2}{3} \times 0.67 \cdot f_{ck} \cdot \frac{4}{7} X_u \right) b$$

$$= (0.29 f_{ck} \cdot X_u + 0.25 f_{ck} \cdot X_u) b$$

$$= 0.54 f_{ck} \cdot b X_u$$

1.2 (a)

At continuous, due to negative bending moment web will be in compression so effective width of web = B.

1.3 (c)

According to **clause 39.1** of **IS 456 : 2000** the maximum compressive strain at the highly compressed extreme fibre in concrete subjected to axial compression and bending and when there is no tension on the section shall be 0.0035 minus 0.75 times the strain at the least compressed extreme fibre.

1.4 (d)

According to IS 456 : 2000, values of partial safety factor γ_f for loads

Load combination	Limit stage of collapse			Limit stage of serviceability		
	DL	IL	WL/EL	DL	IL	WL/EL
1. DL + IL	1.5	1.5	1.0	1.0	1.0	—
2. DL + WL	1.5 or 0.9	—	1.5	1.0	—	1.0
3. DL + EL	1.5 or 0.9	—	1.5	1.0	—	1.0
4. DL + IL + WL/EL	1.2	1.2	1.2	1.0	1.0	0.8

Value of 0.9 is to be used with D.L. when stability against overturning or stress reversal is critical.

2. Footing, Columns, Beams and Slabs

2.1 (a)

Since A_c = Gross cross-section area of concrete. Suppose load P is applied on the column. It will be carried by concrete and the steel bars:

$$\therefore P = P_s + P_c$$

Strain will be equal in both

\therefore From the compatibility requirements

$$\frac{P_s}{A_s E_c} = \frac{P_c}{A_c E_c}$$

We know, $\frac{E_s}{E_c} = m$ = modular ratio and $\frac{P}{A} = \sigma$.

$$\therefore P = \sigma_s A_s + \sigma_c A_c$$

here A_c = gross cross-section area of concrete

$$= \sigma_s A_s + \sigma_c (A_c - A_s)$$

$$= \sigma_s A_s + \sigma_c A_{cv} - \sigma_c A_s \quad \text{From (i)}$$

$$= (m - 1) \sigma_c A_s + \sigma_c A_c$$

2.2 (i) (a), (ii) (b)

When the compression axial load is zero, represented by point R, the column section behaves as a doubly reinforced beam and its moment capacity is given as M_0 . As compressive axial load increases the moment carrying capacity increases. The increase in moment carrying capacity continues until the balanced section is reached, represented by point Q.



POINTS TO REMEMBER

- A column interaction curve is a graphical representation of the combined loads (bending and axial) that will cause the column to fail. An interaction curve defines the different combination of (M_u, P_u) for all possible eccentricities of loading $0 \leq e < \infty$.

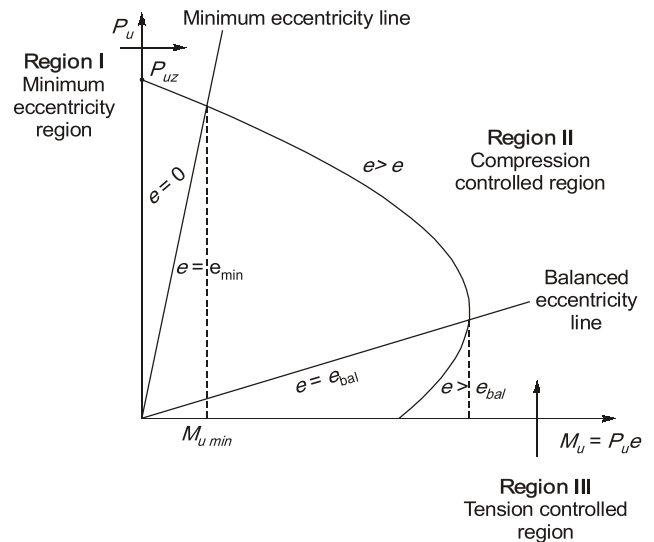

Region-I:

Region-I is known as minimum eccentricity region with $e < e_{min}$.

Note : P_{uz} = Maximum axial load with zero moment.

Mostly the column shall be in compression only when moment $< M_{u min}$.

Region-II

Region-II is called as compression controlled region. It shows when the load on column is reduced, maximum moment capacity of the column will be increasing.

When the loading eccentricity is greater than e_{min} and less than that corresponding to the 'balanced failure' condition is $e < e_b$ yielding of longitudinal steel intension doesnt takes place and failure occurs at the ultimate limit state by crushing of concrete at the highly compressed edge.

Region-III

Region-III is called tension controlled region. Here tensile stresses are developed and moment effect is more than the load effect. When the load on column is reduced moment capacity also get reduced due to which the curve turns inwards. When $e > e_b$ failure will be initiated by the yielding of tension steel.

Note: When $e = e_b$, both crushing of concrete and yielding of steel occur simultaneously.

$$\Rightarrow \frac{1}{46,400} - \frac{e}{75.8 \times 10^7} \times 156 = 0$$

$$\Rightarrow e = 104.72 \text{ mm}$$

3.2 (b)

In post-tensioned, one wire loss due to elastic shortening will be zero.

In case of **multiple wire post-tensioning**, usually tendons are not stretched simultaneously. Moreover, the first tendon that is stretched is shortened by the subsequent stretching of all the other tendons, and the last tendon is not shortened by any subsequent stretching. Therefore in multiple wire, stress loss of prestressing is more if the wires are tensioned one after another.

3.3 (d)

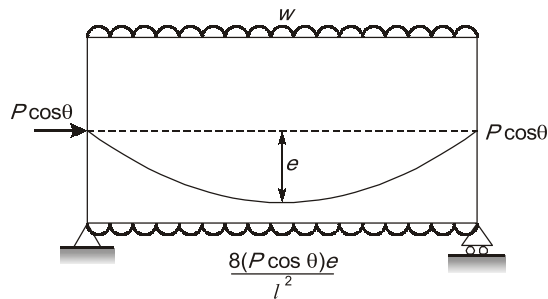
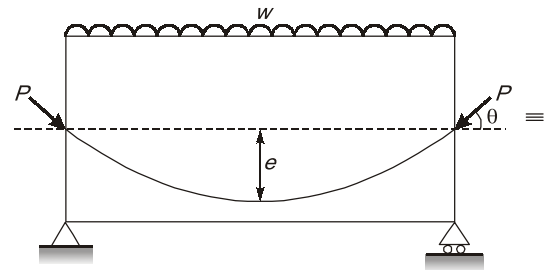

For fully counteract the effect of external load.

$$M = Pe \cos \theta$$

$$\therefore P = \frac{M}{e \cos \theta}$$

Hence prestressing force (P) depends upon M and e.



3. Prestressed Concrete

3.1 (c)

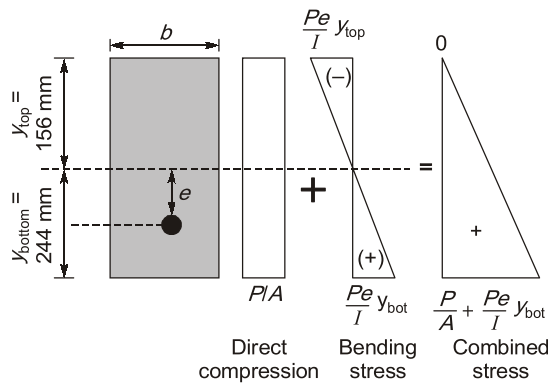

$$\frac{P}{A} - \frac{Pe}{I} y_{top} = 0$$

Design of Steel Structures

UNIT IV

CONTENTS

1. Structural Fasteners 23
2. Compression Member 23
3. Beams 23
4. Plate Girders and Industrial Roofs 23
5. Plastic Analysis 23

Design of Steel Structures

1. Structural Fasteners

- 1.1 The effective section of a fillet weld is represented by a triangle ABC with sides S_1 , S_2 and S_3 such that $S_3 > S_2 > S_1$. If the allowable shear stress in weld material is τ , the resistance of weld per unit length is

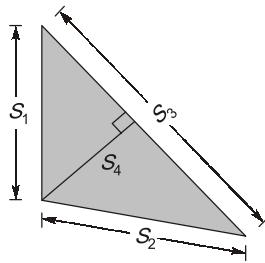

- (a) $S_1\tau$ (b) $S_2\tau$
 (c) $S_3\tau$ (d) $S_4\tau$

[1992 : 1 Mark]

- 1.2 A group of rivets at a joint is subjected to in plane torsion moment M . The rivets have finished areas of cross-section $A_i (i = 1, 2, \dots, n)$ and distances $r_i (i = 1, 2, \dots, n)$ from CG of the rivet group as shown in figure. The shear force developed in i^{th} rivet is proportional to

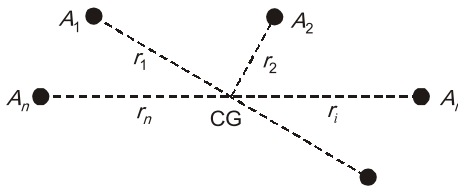

- (a) area of cross-section, A_i only
 (b) distance from CG of group, r_i only
 (c) both A_i and r_i
 (d) Polar moment of inertia of group of area A_i

[1992 : 1 Mark]

2. Compression Member

- 2.1 The width to thickness ratio limitations on the plate elements under compression in steel members are imposed by **IS 800 : 1984** in order to avoid
- (a) too large a deflection of the element before reaching yield stress
 (b) too large a deflection of the member before reaching yield stress

- (c) local buckling of the element before reaching the yield stress
 (d) fabrication difficulties

[1993 : 1 Mark]

3. Beams

- 3.1 Which one of the following factors does not affect the lateral buckling strength of a steel I-section undergoing bending about its major axis?
- (a) Boundary conditions at the ends
 (b) Radius of gyration about the minor axis of the section
 (c) Radius of gyration about the major axis of the section
 (d) Laterally unsupported length of the compression flange

[1993 : 1 Mark]

4. Plate Girders and Industrial Roofs

- 4.1 A plate girder I-section is made by groove welding stress-free web plate to two stress-free flange plates. After cooling of the welds to the room temperature, the residual stress would be
- (a) tensile at the free edges of the flanges
 (b) compressive at the free edges of the flanges
 (c) compressive at the flange web intersection
 (d) zero everywhere

[1993 : 1 Mark]

5. Plastic Analysis

- 5.1 Number of independent displacement modes (sway mechanisms) for the given frame with the load shown in figure is/are

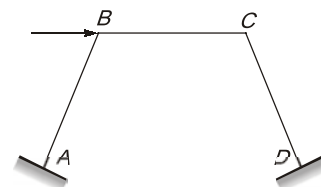

- (a) 4 (b) 1
 (c) 3 (d) 2

[1991 : 1 Mark]

- 5.2 Equilibrium condition, yield conditions ($M \leq M_p$) and mechanism condition (formation of a plastic collapse mechanism) are the conditions to be satisfied by any correct plastic analysis results. Which of the above conditions does the statical methods of plastic analysis consider?
- (a) Equilibrium condition alone
 (b) Equilibrium and mechanism conditions
 (c) Yield and mechanism conditions
 (d) Equilibrium and yield conditions

[1993 : 1 Mark]

- 5.3 The shape factor for a rectangular section is
- (a) 1.00 (b) 1.50
 (c) 2.00 (d) 2.50

[1994 : 2 Marks]



Answers Design of Steel Structures

1.1 (d) 1.2 (c) 2.1 (c) 3.1 (c) 4.1 (b) 5.1 (b) 5.2 (d) 5.3 (b)

Explanations Design of Steel Structures

1. Structural Fasteners

1.1 (d)

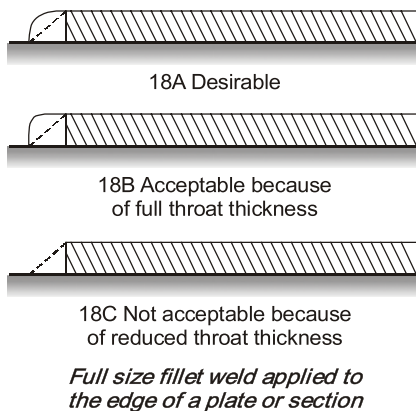

Effective throat thickness is the shortest distance from the root of fillet weld to the hypotenuse of the inscribed right triangle with the weld. Fillet weld is always assumed to resist the load by shearing action on its throat.

\therefore Throat thickness = S_4 (From figure)
 and resistance of weld per unit length = τS_4

2. Compression Member

2.1 (c)

Plate elements of a cross-section may buckle locally due to compressive stresses. The local buckling can be avoided before the limit state is reached by limiting the width to thickness ratio of each element of a cross-section subjected to compression due to axial force, moment or shear.

The limiting width to thickness ratio for rolled section where compression element is outstanding elements of compressive flange is

$$\frac{b}{t_f} < 9.4\epsilon \quad \text{for plastic section}$$

$$\frac{b}{t_f} < 10.5\epsilon \quad \text{for compact section}$$

$$\frac{b}{t_f} < 15.7 \quad \epsilon \text{ for semi-compact section}$$

3. Beams

3.1 (c)

As per IS : 800-1984.

The maximum deflection of a beam should not exceed $1/325$ of span in general. This may be exceeded in case where greater deflection does not affect the strength or crack the floor finishing.

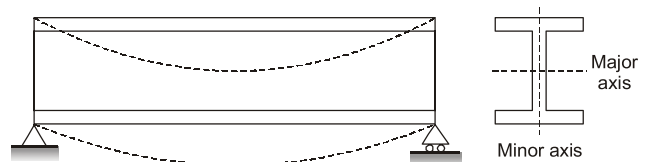

Buckling takes place about minor axis and minimum radius of gyration governs the central buckling strength. Hence, radius of gyration about major axis of section does not affect the lateral buckling strength.

4. Plate Girders and Industrial Roofs

4.1 (b)

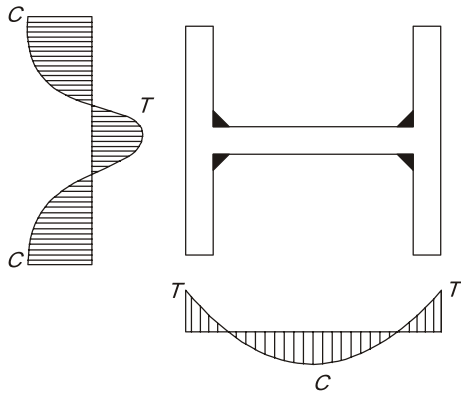

5. Plastic Analysis

5.1 (b)

N = No. of possible location of plastic hinges
 = 4 (A, B, C and D)

D_s = Degree of static indeterminacy
 = $3m + r_e - 3j = 3 \times 3 + 6 - 3 \times 4$
 = 3

No. of independent displacement modes,
 = $N - D_s = 4 - 3$
 = 1

5.2 (d)

The statical method of analysis is based on the lower bound theorem. The objective is to find an equilibrium bending moment diagram in which $M \leq M_p$. Then the ultimate load is computed by solving equilibrium equation.

5.3 (b)

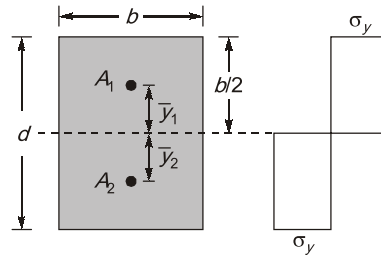

Consider a rectangular section of width 'b' and depth 'd'.

$$\begin{aligned} \text{Shape factor} &= \frac{\text{Plastic section modulus}}{\text{Elastic section modulus}} \\ &= \frac{Z_p}{Z_e} \end{aligned}$$

Elastic section modulus,

$$Z_e = \frac{I}{y_{\max}} = \frac{\frac{bd^3}{12}}{\frac{d}{2}} = \frac{bd^2}{6}$$

Plastic section modulus,

$$\begin{aligned} Z_p &= A_1 \bar{y}_1 + A_2 \bar{y}_2 \\ &= \frac{A}{2} (\bar{y}_1 + \bar{y}_2) \\ &= \frac{b \cdot d}{2} \left[\frac{d}{4} + \frac{d}{4} \right] = \frac{bd^2}{4} \end{aligned}$$

$$\therefore \text{Shape factor} = \frac{\frac{bd^2}{4}}{\frac{bd^2}{6}} = \frac{6}{4} = \frac{3}{2} = 1.5$$



CONTENTS

1. Properties of Soils 27
2. Classification of Soils and Clay Minerals 27
3. Effective Stress and Permeability 27
4. Seepage Analysis 27
5. Compaction of Soil 28
6. Consolidation of Soils 28
7. Shear Strength of Soil 28
8. Retaining Wall/Earth Pressure Theories 28
9. Stability Analysis of Slopes 29
10. Shallow Foundation and Bearing Capacity 29
11. Deep Foundation 29
12. Soil Stabilization and Soil Exploration 30

Geotechnical Engineering

1. Properties of Soils

1.1 For sand of uniform spherical particles, the void ratios in the loosest and the densest states are..... and respectively.

[1991 : 2 Marks]

1.2 A saturated sand sample has dry unit weight of 18 kN/m^3 and a specific gravity of 2.65. If $\gamma_w = 10 \text{ kN/m}^3$, the water content of the soil is....

[1991 : 2 Marks]

1.3 The atterberg limits of a clay are 38%, 27% and 24.5%. It's natural water content is 30%. The clay is in state.

[1994 : 2 Marks]

1.4 The void ratio of a soil sample is 1, the corresponding porosity of the sample is

[1994 : 1 Mark]

2. Classification of Soils and Clay Minerals

2.1 The maximum possible value of Group Index for a soil is.....

[1991 : 2 Marks]

2.2 Write True/False in the answer book.
The charge on kaolinite is due to one aluminium substitution for every four hundredth silicon ion.

[1992 : 1 Mark]

2.3 The description 'sandy silty clay' signifies that
(a) the soil contains unequal proportions of the three constituents, in the order, sand > silt > clay

(b) the soil contains equal proportions of sand, silt and clay

(c) the soil contains unequal proportions of the three constituents such that clay > silt > sand

(d) there is no information regarding the relative proportions of the three

[1992 : 1 Mark]

2.4 Write True/False in the answer book.

The 'A' line in the plasticity chart separates organic clays from inorganic clays.

[1992 : 1 Mark]

2.5 Write True/False in the answer book.
A soil having a uniformity coefficient smaller than about 2 is considered 'uniform'.

[1992 : 1 Mark]

2.6 The swelling nature of black cotton soil is primarily due to the presence of

- (a) Kaolinite (b) Illite
(c) Montmorillonite (d) Vermiculite

[1993 : 1 Mark]

3. Effective Stress and Permeability

3.1 The coefficient of permeability of a soil is $5 \times 10^{-5} \text{ cm/sec}$ for a certain pore fluid. If the viscosity of the pore fluid is reduced to half, the coefficient of permeability will be

- (a) $5 \times 10^{-5} \text{ cm/sec}$ (b) $10 \times 10^{-5} \text{ cm/sec}$
(c) $2.5 \times 10^{-5} \text{ cm/sec}$ (d) $1.25 \times 10^{-5} \text{ cm/sec}$

[1991 : 1 Mark]

3.2 The difference between the free water levels in two wells 48 m apart in an aquifer is 0.6 m. It took an interval of 8 hours between detecting the traces of a tracer material at the two wells in succession. The porosity of the aquifer is 25%. The coefficient of permeability of the aquifer is cm/sec.

[1991 : 2 Marks]

3.3 Write True/False in the answer book.
Effective stresses in a sand layer below a lake do not alter as the level fluctuates.

[1994 : 1 Mark]

4. Seepage Analysis

4.1 Along a phreatic line in an earth dam
(a) the total head is constant but not zero
(b) the total head is everywhere zero
(c) the pressure head is everywhere zero
(d) None of the above

[1991 : 1 Mark]

4.2 The number of flow channels and head drops is 4 and 12 respectively. If the difference in the upstream and downstream water levels is 3 m, what is the discharge per meter width of a sheet pile wall, if $k = 0.1$ m/s?

[1992 : 2 Marks]

4.3 Write True/False in the answer book.
Flow lines and equipotential lines in a flow net are orthogonal to each other.

[1994 : 1 Mark]

4.4 Write True/False in the answer book.
Water pressure is atmospheric at all points on a phreatic line. Phreatic line is, therefore, an equipotential line.

[1994 : 1 Mark]

5. Compaction of Soil

5.1 The zero-air voids curve is non-linear owing to

- the standard proctor test data of dry density and corresponding water content plotting as a non-linear curve
- the dry density at 100% saturation being a non-linear function of the void-ratio
- the water content altering during compaction
- the soil being compacted with an odd number of blows

[1992 : 1 Mark]

6. Consolidation of Soils

6.1 Terzaghi's one-dimensional consolidation theory assumes that

- e vs. p relationship is linear
- e vs. $\log_{10} p$ relationship is linear
- p vs. $\log_{10} e$ relationship is linear
- e vs. $\log_{10} \frac{p}{p_0}$ relationship is linear

[1991 : 1 Mark]

6.2 The coefficient of consolidation is used for

- establishing the duration of primary consolidation
- estimating the amount of settlement for a load increment
- determining the depth to which the soil is stressed when loads are applied on the surface of a soil deposit
- determining the preconsolidation pressure for soil deposits known to be over consolidated

[1992 : 1 Mark]

6.3 Write True/False in the answer book.
Fifty per cent of the consolidation at a site subjected to a stress level of 200 kPa occurred in two months. If the site had been loaded to 400 kPa, fifty per cent of the consolidation would occur in four months.

[1994 : 1 Mark]

7. Shear Strength of Soil

7.1 Write True/False in the answer book.
If the Mohr circle for a given state of stress lies entirely below the Mohr envelope for a soil, then the soil will be unstable for that state of stress.

[1992 : 1 Mark]

7.2 An unconfined compression test yielded a strength of 0.1 N/mm². If the failure plane is inclined at 50° to the horizontal, what are the values of the shear strength parameters?

[1992 : 2 Marks]

7.3 In a drained triaxial compression test conducted on dry sand, failure occurred when the deviator stress was 218 kN/m² at a confining pressure of 61 kN/m². What is the effective angle of shearing resistance and the inclination of failure plane to major principal plane?

- | | |
|--------------------------|--------------------------|
| (a) $34^\circ, 62^\circ$ | (b) $34^\circ, 28^\circ$ |
| (c) $40^\circ, 25^\circ$ | (d) $40^\circ, 65^\circ$ |

[1993 : 2 Marks]

8. Retaining Wall/Earth Pressure Theories

8.1 The earth pressure for the design of bridge abutments is taken as

- active thrust
- passive thrust
- thrust in at rest condition
- None of the above

[1993 : 1 Mark]

8.2 A vertical wall 6 m high above the water table, retains a 20° soil slope, the retained soil has a unit weight of 18 kN/m³, the appropriate shear strength parameters are $C = 0$ and $\phi = 40^\circ$. The coefficient of active earth pressure to be used in estimating the active pressure acting on the wall is

[1994 : 2 Marks]

9. Stability Analysis of Slopes

9.1 For the trial slip circle shown in figure, calculate the factor of safety. [(Given: weight of the soil = 346 kN/m, unit weight of soil = 19 kN/m³, $C_u = 20$ kN/m²)]

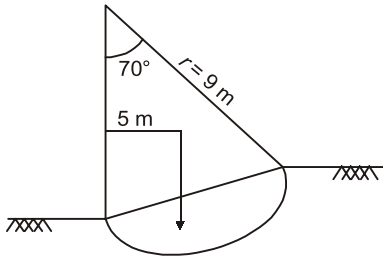

[1993 : 2 Marks]

9.2 Write True/False in the answer book. The problem of slope stability analysis assuming circular slip surfaces and considering equilibrium of the free body as a whole is statically determinate.

[1994 : 1 Mark]

10. Shallow Foundation and Bearing Capacity

10.1 The ultimate bearing capacity of a surface strip footing on clay, according to Terzaghi's theory, is

- (a) $5.7 C$
- (b) $5.14 C$
- (c) $q_u B$
- (d) $9 C$

Where,

C – Unit cohesion

q_u – Unconfined compressive strength, and

B – Width of footing

[1991 : 1 Mark]

10.2 Match the following

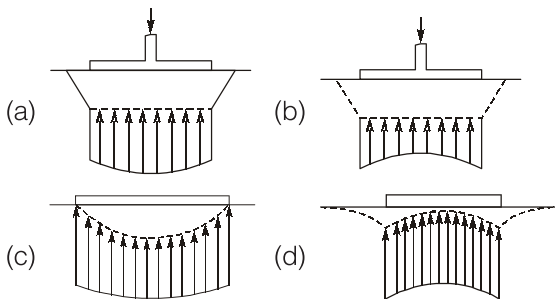

1. Flexible footing on Cohesive soil
2. Rigid footing on Cohesive soil
3. Rigid footing on Cohesionless soil
4. Flexible footing on Cohesionless soil

Codes:

	A	B	C	D
(a)	3	2	1	4
(b)	3	2	4	1
(c)	2	3	1	4
(d)	2	3	1	4

[1991 : 2 Marks]

10.3 Write True/False in the answer book.

The derivation of the ultimate bearing capacity of a strip footing is an extension of the case of passive earth pressure on a rough wall.

[1992 : 1 Mark]

10.4 Increasing the depth of foundation in saturated clays results in an increased ultimate bearing capacity for strip footings

- (a) because the bearing capacity factor, N_q decreases
- (b) because the bearing capacity factor, N_c , increases as the depth increases
- (c) the term in the bearing capacity equation, qN_q , increases with depth
- (d) because the angle of internal friction decreases as the depth of foundation increases

[1992 : 1 Mark]

11. Deep Foundation

11.1 In which one of the following conditions, is the pile system as shown in figure highly inappropriate?

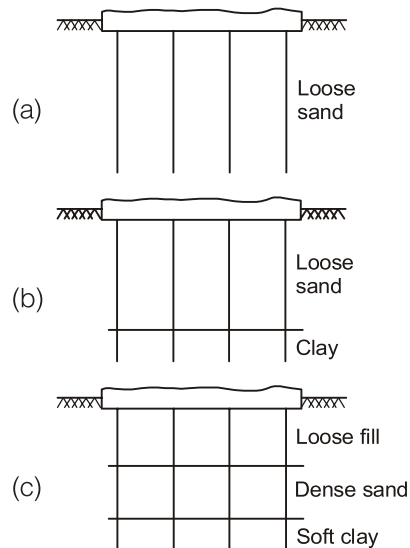

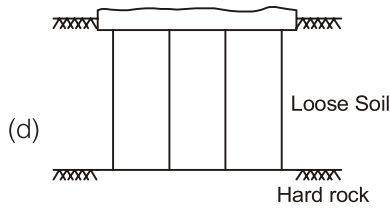

[1993 : 1 Mark]

12. Soil Stabilization & Soil Exploration

12.1 A sampling tube has an inner diameter of 72 mm and an outer diameter of 75 mm. The area ratio is.....

[1991 : 2 Marks]



Answers Geotechnical Engineering

- 1.1 (Sol.) 1.2 (Sol.) 1.3 (Sol.) 1.4 (Sol.) 2.1 (Sol.) 2.2 (Sol.) 2.3 (Sol.) (c) 2.4 (Sol.)
 2.5 (Sol.) 2.6 (c) 3.1 (b) 3.2 (Sol.) 3.3 (Sol.) 4.1 (c) 4.2 (Sol.) 4.3 (Sol.)
 4.4 (Sol.) 5.1 (b) 6.1 (a) 6.2 (a) 6.3 (Sol.) 7.1 (Sol.) 7.2 (Sol.) 7.3 (d)
 8.1 (c) 8.2 (Sol.) 9.1 (Sol.) 9.2 (Sol.) 10.1 (a) 10.2 (a) 10.3 (Sol.) 10.4 (c)
 11.1 (c) 12.1 (Sol.)

Explanations Geotechnical Engineering

1. Properties of Soils

1.1 Sol.

In loosest state

Solids are to be arranged in cubical array in which each solid surrounded by 6 spheres

Total volume of solids

$$= n \times \frac{4}{3} \pi \left(\frac{d}{2}\right)^3 = \frac{n\pi d^3}{6} \quad [\text{Solid diameter} = d]$$

Assume 1 m × 1 m × 1 m cube

$$\text{Total number of spheres} = \frac{1}{d} \cdot \frac{1}{d} \cdot \frac{1}{d} = \frac{1}{d^3}$$

Total volume of cube = 1 m³

$$\text{Total volume of solids} = \frac{\pi}{6} = 0.523$$

Total volume voids (V_v) = 1 - 0.523 = 0.477

$$e = \frac{V_v}{V_s} = \frac{0.477}{0.523} = 0.91$$

For densest state

Solids are arranged Rhombohedral array in which each solid is surrounded by 12 neighbouring solids

$$e = 0.35$$

1.2 Sol.

$$\therefore \gamma_d = \frac{G\gamma_w}{1+e}$$

$$\Rightarrow 18 = \frac{2.65 \times 10}{1+e}$$

$$\Rightarrow e = 0.47$$

$$wG = es$$

$$\Rightarrow w \times 2.65 = 0.47 \times 1$$

$$\Rightarrow w = 0.17$$

1.3 Sol.

It is given that, **Atterberg limits** of clay such as shrinkage limit (w_s), plastic limit (w_p) and liquid limit (w_L) are 24.5%, 27% and 38% respectively.

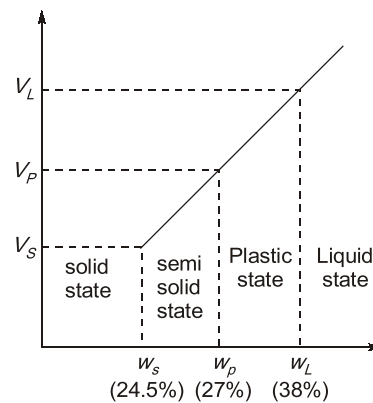

∴ Consistency index,

$$I_C = \frac{w_L - w}{w_L - w_p} = \frac{38 - 30}{38 - 27} = 0.727$$

Also, Liquidity index,

$$I_L = \frac{w - w_p}{w_L - w_p} = \frac{30 - 27}{38 - 27} = 0.2727$$

Consist.	Description	I_C	I_L
Liquid	Liquid	<0	>1
Plastic	Very soft	0-0.25	0.75-1.00
	Soft	0.25-0.5	0.50-0.75
	Medium stiff	0.50-0.75	0.25-0.50
	Stiff	0.75-1.00	0.0-0.25
Semi-solid	Very stiff	>1	<0
	OR Hard	>1	<0
Solid	Hard OR	>1	<0
	Very hard	>1	<0

∴ Soil is in plastic state.

1.4 Sol.

We know that porosity,

$$n = \frac{e}{1+e}$$

$$\Rightarrow n = \frac{1}{1+1} = \frac{1}{2} = 0.5$$

2. Classification of Soils and Clay Minerals

2.1 Sol.

$$\text{Group index} = 0.2a + 0.005ac + 0.01 bd$$

$$\%P - 35 \ngtr 40 = a$$

$$\%P - 15 \ngtr 40 = b$$

$$\omega_L - 40 \ngtr 20 = c$$

$$I_p - 10 \ngtr 20 = d$$

$$\left. \begin{matrix} a_{\max} = 40 \\ b_{\max} = 40 \\ c_{\max} = 20 \\ d_{\max} = 20 \end{matrix} \right\} GI_{\max} = 20$$

Where %P is the percentage of soil passing 75 μ sieve.

Note: The group index value of soils vary in line range of 0-20.

2.2 Sol.

Substitution of silica by aluminum does not occur in kaolinite clay mineral. Such substitution only occur in Illite clay mineral.

Hence it is **false**.

2.3 (c)

It is a general nomenclature, if we write 'Silty Sand' then it means sand content is more than the silt. Similarly in case of 'sandy silty clay' clay > silt > sand

2.4 Sol.

TRUE

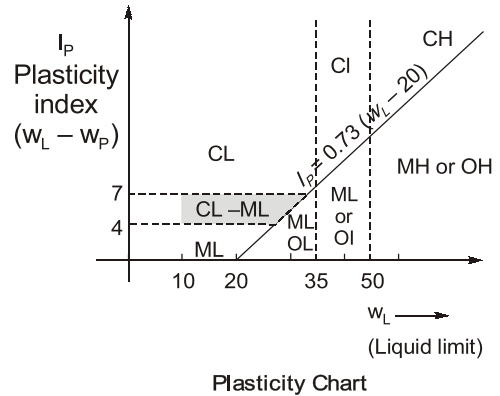

2.5 Sol.

TRUE

For soil to be well graded $C_u > 4$ for gravels and greater than 6 for sand. A poorly graded soil is either uniform or gap graded.

If uniformity coefficient (C_u) < 2, soil is uniformly graded. This means curves will become almost vertical depicting same size of all grains in the soil.

2.6 (c)

Montmorillonite has a large affinity for water, because of this, clay soil containing montmorillonite mineral are susceptible to substantial volume changes. They swell as the water gains entry into the lattice structure and shrink if the water is removed. In a moist state, montmorillonite is highly plastic and has little internal friction. In India clay soils containing montmorillonite mineral, are known as **Black Cotton Soil**.

Note: Montmorillonite is also called Smectite.

3. Effective Stress and Permeability

3.1 (b)

$$\begin{aligned} \therefore k &= \frac{1}{c} \cdot \frac{1}{s^2} \cdot \frac{\gamma_w}{\mu} \cdot \frac{e^3}{1+e} \\ \Rightarrow k &\propto \frac{1}{\mu} \\ \Rightarrow \frac{k_2}{k_1} &= \frac{\mu_1}{\mu_2} \\ \Rightarrow k_2 &= 5 \times 10^{-5} \times \frac{\mu}{\mu/2} \\ &= 10 \times 10^{-5} \text{ cm/sec} \end{aligned}$$

3.2 Sol.

According to **Darcy's law**, $V \propto i$

$$V = ki$$

V = flow velocity

i = hydraulic gradient = h/L

$$\therefore V = \frac{kh}{L} = k \times \frac{0.6}{48}$$

We know that,
Seepage velocity,

$$V_s = \frac{V}{n}$$

$$\Rightarrow n \times V_s = V$$

$$\Rightarrow n \times V_s = k \times \frac{0.6}{48}$$

$$\Rightarrow 0.25 \times \frac{48}{8 \times 60 \times 60} = k \times \frac{0.6}{48}$$

$$\begin{aligned} \Rightarrow k &= 0.033 \text{ m/sec} \\ &= 3.33 \text{ cm/sec} \end{aligned}$$

3.3 Sol.

TRUE

4. Seepage Analysis

4.1 (c)

It is top flow line which follows the path of base parabola. It is a stream line. The pressure on this line is atmospheric (zero) and below this line pressure is hydrostatic. So pressure head is zero everywhere.

4.2 Sol.

$$N_f = 4, N_d = 12;$$

$$h = 3 \text{ m}, k = 0.1 \text{ m/s}$$

$$\begin{aligned} \therefore q &= kh \frac{N_f}{N_d} = 0.1 \times 3 \times \frac{4}{12} \\ &= 0.1 \text{ m}^3/\text{s/m} \end{aligned}$$

4.3 Sol.

True

4.4 Sol.

False

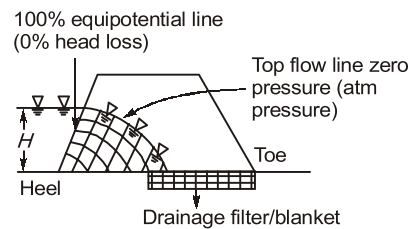

It is top flow line which follows the path of base parabola. It is a stream line. The pressure on this line is atmospheric (zero) and below this line pressure is hydrostatic.

6. Consolidation of Soils

6.1 (a)

Terzaghi's assumes that coefficient of compressibility is constant. Hence e vs. p relationship is linear.

6.2 (a)

As we know,

$$T_v = \frac{C_v t}{H^2}$$

$$\therefore t = T_v \frac{H^2}{C_v}$$

For a given degree of consolidation U , time factor T_v has a certain value, depending upon the boundary conditions governing the problem.

\therefore The time required for a soil to reach a given degree of consolidation can be calculated by knowing the length of drainage path and coefficient of consolidation.

6.3 Sol.

False

7. Shear Strength of Soil

7.1 Sol.

FALSE

If the Mohr circle for a given state of stress lies entirely below the Mohr envelope for a soil, then the soil will be stable for that state of stress.

7.2 Sol.

For unconfined compression test,

$$\sigma_3 = 0$$

$$\therefore q_u = \sigma_1 = 2c \tan\left(45^\circ + \frac{\phi}{2}\right)$$

$$\text{Now, } \theta_c = 50^\circ$$

$$\text{Now, } \theta_c = 45^\circ + \frac{\phi}{2}$$

$$\Rightarrow 50 = 45^\circ + \frac{\phi}{2}$$

$$\therefore \phi = 10^\circ$$

$$\text{Now, } q_u = 0.1 \text{ N/mm}^2$$

$$\therefore 0.1 = 2c \tan(50^\circ)$$

$$\Rightarrow c = \frac{0.1}{2 \tan 50^\circ} = 0.0419 \text{ N/mm}^2$$

\therefore Shear strength parameters c and ϕ are 0.0419 N/mm^2 and 10° respectively.

7.3 (d)

$$\sigma_1 = \sigma_3 \tan^2\left(45^\circ + \frac{\phi}{2}\right) + 2c \tan\left(45^\circ + \frac{\phi}{2}\right)$$

$$\text{Now, } \sigma_1 = \sigma_3 + \sigma_d$$

$$\sigma_d = 218 \text{ kN/m}^2$$

$$\sigma_3 = 61 \text{ kN/m}^2$$

$$\therefore \sigma_1 = 218 + 61 = 279 \text{ kN/m}^2$$

$$\text{Also, } c = 0$$

$$\therefore \sigma_1 = \sigma_3 \tan^2\left(45^\circ + \frac{\phi}{2}\right)$$

$$\Rightarrow 279 = 61 \tan^2\left(45^\circ + \frac{\phi}{2}\right)$$

$$\Rightarrow 4.5738 = \tan^2\left(45^\circ + \frac{\phi}{2}\right)$$

$$\Rightarrow \tan\left(45^\circ + \frac{\phi}{2}\right) = 2.139$$

$$\Rightarrow 45^\circ + \frac{\phi}{2} = 64.94$$

$$\Rightarrow \phi = 39.88^\circ \cong 40^\circ$$

$$\text{and } \theta_c = 45^\circ + \frac{\phi}{2} = 45^\circ + \frac{40^\circ}{2}$$

$$\cong 65^\circ$$

8. Retaining Wall/Earth Pressure Theories

8.1 (c)

'At rest' earth pressure exist when wall earth system is rigid that is when no movement is occurring as in case of deep basement wall or the U-shaped abutment of bridge.

8.2 Sol.

$$H = 6 \text{ m}$$

$$\beta = 20^\circ$$

$$\gamma = 18 \text{ kN/m}^3$$

$$c = 0; \alpha = 40^\circ$$

$$k_a = \cos\beta \left[\frac{\cos\beta - \sqrt{\cos^2\beta - \cos^2\alpha}}{\cos\beta + \sqrt{\cos^2\beta - \cos^2\alpha}} \right]$$

$$k_a = \cos\beta \left[\frac{\cos 20^\circ - \sqrt{\cos^2 20^\circ - \cos^2 40^\circ}}{\cos 20^\circ + \sqrt{\cos^2 20^\circ - \cos^2 40^\circ}} \right]$$

$$k_a = 0.9397 \times \frac{0.39545}{1.484} = 0.25$$

9. Stability Analysis of Slopes

9.1 Sol.

As we know, Factor of safety,

$$F = \frac{C_u L r}{w \bar{x}} = \frac{\text{Resisting moment}}{\text{Actuating moment}}$$

$$\text{Now, } C_u = 20 \text{ kN/m}^2$$

$$L = \frac{2\pi r \times \theta}{360^\circ} = \frac{2 \times \pi \times 9 \times 70^\circ}{360^\circ}$$

$$= 10.995 \text{ m}$$

$$\therefore \text{FOS} = \frac{20 \times 10.995 \times 9}{346 \times 5} = 1.144$$

9.2 Sol.

True

10. Shallow Foundation and Bearing Capacity

10.1 (a)

Ultimate bearing capacity for a strip footing is

$$q_u = CN_c + \gamma D_f N_q + 0.5 \gamma B N_\gamma$$

But for C -soil,

$$q_u = CN_c$$

Here, $N_c =$ bearing capacity factor = 5.7

$$\Rightarrow q_u = 5.7 C$$

10.3 Sol.

TRUE

[It is Rankine's Theory which is not in syllabus now]

10.4 (c)

The bearing capacity factors, N_c , N_q have no relation with depth and depend upon angle of internal friction only.

As per Terzaghi's theory

$$q_u = cN_c + qN_q + \frac{1}{2} B_\gamma N_\gamma \quad \dots(i)$$

For clay,

$$N_c = 5.7$$

$$N_q = 1$$

$$N_\gamma = 0$$

From (i)

$$\begin{aligned} q_u &= 5.7 c + q \\ &= 5.7c + \gamma D_f \end{aligned}$$

Hence, ultimate bearing capacity for strip footing increases with depth because $qN_q = \gamma D_f N_q$, increases with depth.

11. Deep Foundation

11.1 (c)

Negative skin friction may occur in option (c) because of presence of loose fill.

12. Soil Stabilization & Soil Exploration

12.1 Sol.

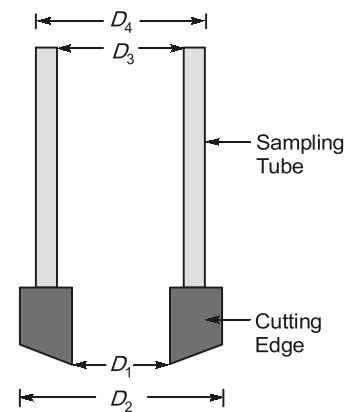

Area Ratio,

$$A_r = \frac{D_2^2 - D_1^2}{D_1^2} \times 100 = \frac{75^2 - 72^2}{72^2} = 8.5\%$$



Fluid Mechanics & Fluid Machines

UNIT

VI

CONTENTS

1. Fluid Kinematics 36
2. Fluid Dynamics & Flow Measurements 36
3. Flow Through Pipes 36
4. Boundary Layer Theory, Drag and Lift 36
5. Turbulent Flow 36
6. Dimensional Analysis 36
7. Impact of Jets and Turbines 37
8. Hydraulic Pumps 37
9. Open Channel Flow 37

Fluid Mechanics & Fluid Machines

1. Fluid Kinematics

- 1.1 Let the x and y components of velocity in steady, two dimensional, incompressible flow be linear function of x and y such that

$$V = (ax + by) i + (cx + dy) j$$

where a , b , c and d are constants. The condition for which the flow is irrotational is.....

[1994 : 2 Marks]

2. Fluid Dynamics & Flow Measurements

- 2.1 In a nominal 90° triangular notch discharging under invariant head, the error in the estimated discharge due to 2% error in the vertex angle is.....

[1991 : 2 Marks]

3. Flow Through Pipes

- 3.1 The head loss due to sudden expansion is expressed by

$$(a) \frac{V_1^2 - V_2^2}{2g} \quad (b) \left(\frac{V_1 - V_2}{2g} \right)^2$$
$$(c) \frac{(V_1 - V_2)^2}{g} \quad (d) \frac{(V_1 - V_2)^2}{2g}$$

[1992 : 1 Mark]

- 3.2 The procedure to follow in solving for discharge when h_f (head loss) L (pipe length), D (inside diameter), ν (kinematic viscosity) and k (wall roughness) are given, is to

- assume a f (friction factor), compute V , R (Reynolds number), k/D , look up for f and repeat if necessary
- assume a R , compute f , check k/D , etc.
- assume a V , compute R , look up for f , compute V again etc.
- assume a O , compute V , R , look up, etc.

[1994 : 1 Mark]

- 3.3 Branching pipe problems are usually solved
- by assuming the head loss is the same through each pipe

(b) by equivalent lengths

(c) by assuming the elevation of the hydraulic grade line at the junction point and trying to satisfy continuity

(d) by assuming a distribution which satisfies continuity and computing a direction

[1994 : 1 Mark]

4. Boundary Layer Theory, Drag and Lift

- 4.1 A smooth flat plate is in a parallel flow stream. The ratio of the drag over the upstream half of the plate to that over the entire plate is..... Assume the average skin friction coefficient is proportional to $(Re_x)^{-1/2}$.

[1994 : 1 Mark]

5. Turbulent Flow

- 5.1 An old pipeline which has relative roughness of $k/D = 0.005$ operates at a Reynold's number which is sufficiently high for the flow to be beyond the range of viscous influence and the corresponding $f = 0.03$. If through further aging, the relative roughness is doubled and the corresponding $f = 0.0375$, the power increase required to maintain the same rate of flow would be about

- 25%
- 50%
- 75%
- 100%

[1993 : 2 Marks]

6. Dimensional Analysis

- 6.1 An 1 : 50 model of an ogee spillway crest records an acceleration of 1.5 m/sec^2 at a certain location. The homologous value of acceleration in the prototype is.....

[1991 : 2 Marks]

- 6.2 The number of π parameters needed to express the function $F(A, V, t, \mu, L) = 0$ are

- 5
- 4
- 3
- 2

[1994 : 1 Mark]

7. Impact of Jets and Turbines

- 7.1 An impulse turbine
- (a) always operates submerged
 - (b) makes use of a draft tube
 - (c) operates by initial complete conversion to kinetic energy
 - (d) converts pressure head into velocity head throughout the vanes

[1994 : 1 Mark]

8. Hydraulic Pumps

- 8.1 Water is to be lifted by a net head of 150 m. Identical pumps each with specific speed of 30 and rotational speed of 1450 rpm with design discharge of $0.2 \text{ m}^3/\text{sec}$ are available. The minimum number of pumps required is

[1991 : 2 Marks]

9. Open Channel Flow

- 9.1 The conjugate depths at a location in a horizontal rectangular channel, 4 m wide, are 0.2 m and 1.0 m. The discharge in the channel is m^3/sec .

[1991 : 2 Marks]

- 9.2 The discharge from a spillway on a horizontal floor is 8 cumecs per meter width. If the depth before the jump is 50 cm, the depth after the jump in metres will be

[1992 : 2 Marks]

- 9.3 A discharge of 1 cumec is flowing in a rectangular channel one meter wide at a depth of 20 cm. The bed slope of the channel is

- (a) mild
- (b) critical
- (c) steep
- (d) adverse

[1992 : 2 Marks]

- 9.4 A right angled triangular notch is used to measure the flow in a flume. If the head measured is 20 cm and $C_d = 0.62$, neglecting the velocity of approach, the discharge in litres/second is

[1992 : 2 Marks]

- 9.5 Water flows in a rectangular channel at a depth of 1.20 m and a velocity of 2.4 m/s. A local rise in the bed of 0.60 m will cause

- (a) the surface to rise
- (b) the surface to fall
- (c) a stationary jump to form
- (d) a surge to travel upstream

[1993 : 1 Mark]

- 9.6 The hydraulic jump always occurs from

- (a) a M_2 curve to a M_1 curve
- (b) a H_3 curve to a H_1 curve
- (c) below normal depth to above normal depth
- (d) below critical depth to above critical depth

[1994 : 1 Mark]



Answers Fluid Mechanics & Fluid Machines

1.1 (Sol.) 2.1 (Sol.) 3.1 (d) 3.2 (a) 3.3 (d) 4.1 (Sol.) 5.1 (a) 6.1 (Sol.) 6.2 (d)
 7.1 (c) 8.1 (Sol.) 9.1 (Sol.) 9.2 (Sol.) 9.3 (c) 9.4 (Sol.) 9.5 (a) 9.6 (d)

Explanations Fluid Mechanics & Fluid Machines**1. Fluid Kinematics****1.1 Sol.**

$$\text{Given } \vec{V} = (ax + by)\hat{i} + (cx + dy)\hat{j}$$

$$\Rightarrow u = ax + by \text{ and } v = cx + dy$$

$$\omega_z = \frac{1}{2} \left[\frac{\partial v}{\partial x} - \frac{\partial u}{\partial y} \right]$$

$$\Rightarrow \omega_z = \frac{1}{2} [c - b]$$

For irrotational flow, the rotational component of velocity should be zero.

$$\Rightarrow \omega_z = 0$$

$$\Rightarrow c = b$$

\therefore required condition is $c = b$

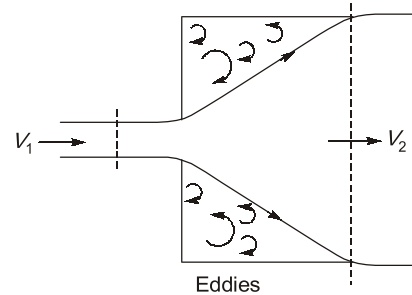

The head loss due to sudden expansion h_e is given by,

$$h_e = \frac{(V_1 - V_2)^2}{2g}$$

Where V_1 and V_2 are velocities at sections before and after enlargement respectively.

2. Fluid Dynamics & Flow Measurements**2.1 Sol.****Method-I**

$$Q = \frac{8}{15} C_d \sqrt{2g} \cdot \tan\left(\frac{\theta}{2}\right) \cdot H^{5/2}$$

$$\frac{dQ}{Q} = \frac{\sec^2(\theta/2)}{2 \tan(\theta/2)} \cdot d\theta$$

$$\theta = 90^\circ; d\theta = 1.8^\circ$$

$$= \frac{1.8 \times \pi}{180} \text{ rad}$$

$$\frac{dQ}{Q} = \frac{\sec^2(45^\circ)}{2 \tan 45^\circ} \times \left(\frac{1.8 \pi}{180} \right)$$

$$= \frac{\pi}{100} = 0.0314$$

$$\therefore \text{Error} = \frac{dQ}{Q} \times 100 = 3.14\%$$

3.2 (a)

Given, h_f, L, D, v & k

Step-1: Assume f

Step-2: Calculate V from $h_f = \frac{fLV^2}{2gD}$

Step-3: Calculate $Re = \frac{VD}{\nu}$

Now on the basis of value of Re , determine if the flow is laminar or turbulent.

Step-4: Now determine, discharge and by back substitution, check the value of f .

Step-5: Assume f value closer to actual and repeat.

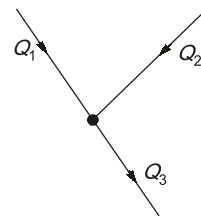
3.3 (d)

Here we have a 3 pipe branch network.

Continuity equation $Q_1 + Q_2 = Q_3$

3. Flow Through Pipes**3.1 (d)**

4. Boundary Layer Theory, Drag and Lift

4.1 Sol.

Given average skin friction coefficient

$$C_D \propto Re_x^{-1/2}$$

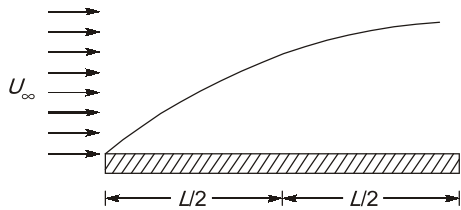

As same width = B

F_{D1} = Drag force on upstream half of the plate

$$\begin{aligned} F_{D1} &= \frac{C}{(Re_L)^{1/2}} \times \frac{1}{2} \rho \times A_1 \times U_\infty^2 \\ &= \frac{C}{\left(\frac{\rho U_\infty L}{\mu}\right)^{1/2}} \times \frac{1}{2} \times \rho \times A_1 \times U_\infty^2 \\ &= \frac{C}{\left(\frac{\rho U_\infty}{\mu}\right)^{1/2}} \times \rho \times A_1 \times U_\infty^2 \times \frac{\sqrt{2}}{\sqrt{L}} \quad \dots(i) \end{aligned}$$

Let F_D = Total drag force on the plate

$$\begin{aligned} &= \frac{C}{(Re_L)^{1/2}} \times \frac{1}{2} \times \rho \times A_2 \times U_\infty^2 \quad (A_2 = 2A) \\ &= \frac{C}{\left(\frac{\rho U_\infty}{\mu}\right)^{1/2}} \times \rho \times A_1 \times U_\infty^2 \times \frac{2}{\sqrt{L}} \quad \dots(II) \end{aligned}$$

Divide eq. (i) and (ii)

$$\frac{F_{D1}}{F_D} = \frac{\frac{\sqrt{2}}{\sqrt{L}}}{\frac{2}{\sqrt{L}}} = \frac{1}{\sqrt{2}}$$

5. Turbulent Flow

5.1 (a)

$$\begin{aligned} h_f &= \frac{fV^2}{2gd} \\ h_f &\propto f \end{aligned}$$

$$\therefore \frac{h_1}{h_2} = \frac{f_1}{f_2} = \frac{0.03}{0.0375} = 0.8$$

$$\Rightarrow h_1 = 0.8 h_2$$

% increase in power required

$$\begin{aligned} &= \frac{P_2 - P_1}{P_1} \times 100 \quad (P \propto h_f) \\ &= \frac{h_2 - h_1}{h_1} \times 100 \\ &= \frac{h_2 - 0.8h_2}{0.8h_2} \times 100 = 25 \end{aligned}$$

6. Dimensional Analysis

6.1 Sol.

According to Froude Law

$$(F_r)_m = (F_r)_p$$

$$\left(\frac{V}{\sqrt{Lg}}\right)_m = \left(\frac{V}{\sqrt{Lg}}\right)_p$$

$$\frac{V_m}{V_p} = \left(\frac{V}{\sqrt{Lg}}\right)_p$$

$$V_r = \sqrt{L_r} \quad \dots(i)$$

$$\frac{L_r}{T_r} = \sqrt{L_r}$$

$$T_r = \sqrt{L_r} \quad \dots(ii)$$

$$a_r = \frac{V_r}{T_r}$$

By eq. (i) and (ii)

$$a_r = \frac{\sqrt{L_r}}{\sqrt{L_r}}$$

$$a_r = 1$$

$$\frac{a_m}{a_p} = 1$$

$$\frac{1.5}{a_p} = 1$$

$$a_p = 1.5 \text{ m/s}^2$$

6.2 (d)

$$f(A, V, t, \mu, L) = 0$$

where

Number of variables, $m = 5$

number of fundamentals dimension, $n = 3$

$$\begin{aligned}\therefore \text{Number of } \pi\text{-terms} &= m - n \\ &= 5 - 3 \\ &= 2\end{aligned}$$

7. Impact of Jets and Turbines

7.1 (c)

In impulse turbine, all the available energy is converted into kinetic energy or velocity head by passing it through a contracting nozzle at the end of penstock.

In a reaction turbine however, only a part of total energy is converted to kinetic energy before the runner is reached. Option (a), (b) and (d) correspond to reaction turbine.

8. Hydraulic Pumps

8.1 Sol.

Total head, $H = 150$ m, Specific speed, $N_s = 30$,
 $N = 1450$ rpm, $Q = 0.2$ m³/s
 Number of pumps, $n = ?$

$$N_s = \frac{N\sqrt{Q}}{H^{3/4}}$$

$$\therefore 30 = \frac{1450\sqrt{0.2}}{H^{3/4}}$$

$$\therefore H = 60.21 \text{ m}$$

Head lift capacity of each pump,
 $H = 60.21$ m

Number of pumps required,

$$n = \frac{150}{60.21} = 2.49 \approx 3 \text{ pumps}$$

9. Open Channel Flow

9.1 Sol.

The relation between critical depth and conjugate depths for a rectangular channel.

$$\frac{2q^2}{g} = y_1 y_2 (y_1 + y_2)$$

$$2y_c^3 = y_1 y_2 (y_1 + y_2)$$

$$y_c^3 = y_1 y_2 \frac{(y_1 + y_2)}{2}$$

$$\Rightarrow \frac{q^2}{g} = \frac{1 \times 0.2 \times 1.2}{2}$$

$$\begin{aligned}\Rightarrow q &= 1.0849 \\ \therefore Q &= q \times b \\ &= 1.0849 \times 4 \\ &= 4.339 \text{ m}^3/\text{sec}\end{aligned}$$

Note: For critical flow condition,

$$F_r = 1$$

$$\frac{Q^2 T}{g A^3} = 1$$

$$\frac{Q^2 B}{g B^3 y_c^3} = 1$$

$$q = \frac{Q}{B}$$

$$\frac{q^2}{g y_c^3} = 1$$

$$\Rightarrow y_c = \left(\frac{q^2}{g} \right)^{1/3}$$

This formula for critical depth is valid only for rectangular section.

9.2 Sol.

$$\frac{2q^2}{g} = y_1 y_2 (y_1 + y_2)$$

$$\frac{2 \times 8^2}{9.81} = 0.5 y_2 (0.5 + y_2)$$

$$\Rightarrow y_2^2 + 0.5 y_2 - 26.095 = 0$$

$$y_2 = 4.864 \text{ m}, -5.364 \text{ m}$$

$$\text{So, } y_2 = 4.864 \text{ m}$$



AVOID MISTAKE

$$\frac{y_1}{y_2} = \frac{1}{2} \left[-1 + \sqrt{1 + 8Fr_1^2} \right]$$

$$\frac{0.5}{y_2} = \frac{1}{2} \left[-1 + \sqrt{1 + 8 \times 7.22^2} \right]$$

$$y_2 = 0.05 \text{ m} \quad \text{[WRONG]}$$

$$\frac{y_2}{y_1} = \frac{1}{2} \left[-1 + \sqrt{8Fr_1^2} \right] \quad \text{[CORRECT]}$$

9.3 (c)

$$F_r^2 = \frac{Q^2 T}{g A^3}$$

$$F_r = \left(\frac{1 \times 1}{9.81 \times 0.2^3} \right)^{1/2} = 3.569 \quad (\text{Supercritical})$$

∴ Steepslope.

$$y_c = \left(\frac{q^2}{g} \right)^{1/3}$$

$$q = \frac{1}{1} = 1 \text{ m}^3/\text{s/m}$$

$$\therefore y_c = \left(\frac{1^2}{9.81} \right)^{1/3} = 0.467 \text{ m}$$

$$y_n = 0.2 \text{ m}$$

Since $y_c > y_n$ hence steep slope.

Note: For $y_c > y_n$, $s_0 > s_c$

$$1. y_c \propto q \quad 2. y_n \propto q \text{ and } \frac{1}{\sqrt{s_0}}$$

9.4 Sol.

$$Q = \frac{8}{15} C_d \sqrt{2g} H^{5/2} \tan 45^\circ$$

Now, $H = 20 \text{ cm} = 0.2 \text{ m}$

$$C_d = 0.62$$

$$\therefore Q = \frac{8}{15} \times 0.62 \times \sqrt{2 \times 9.81} \times (0.2)^{5/2} \times 1 = 0.0262 \text{ m}^3/\text{s} = 26.2 \text{ lps}$$

9.5 (a)

$$F_{r1} = \frac{V_1}{\sqrt{gy_1}} \quad (\because \text{Rectangular channel})$$

$$= \frac{2.4}{\sqrt{9.81 \times 1.2}} = 0.7 < 1$$

So, the flow before the hump is subcritical

$$E_1 = 1.2 + \frac{2.4^2}{2 \times 9.81} = 1.4936 \text{ m}$$

For a given u/s specific energy, (E_1)

$$Q = \frac{1}{n} AR^{2/3} S^{1/2}$$

$$\Delta z \rightarrow (\Delta z)_{\max}$$

$$E_2 \rightarrow E_c$$

$$E_c = \frac{3}{2} y_c = \frac{3}{2} \left(\frac{q^2}{g} \right)^{1/3}$$

$$E_1 = E_2 + \Delta z$$

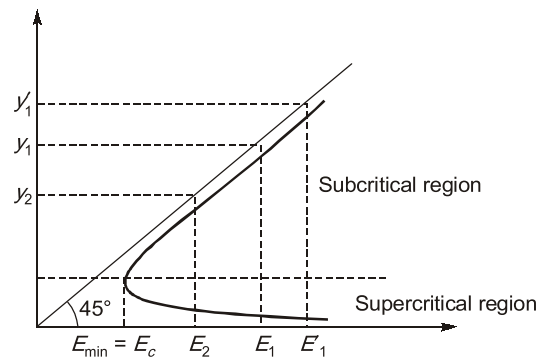

Whenever CDL is crossed to achieve a higher NDL there must be a hydraulic jump.

9.6 (d)

When flow condition changes from supercritical ($Fr > 1$) to subcritical ($Fr < 1$), hydraulic jump occurs. Hydraulic jump always occur from below critical depth to above critical depth.



CONTENTS

1. Water Demand 43
2. Quality Characteristics of Water 43
3. Water Treatment 43
4. Sources of Water Supply, Distribution System
and Well Hydraulics 43
5. Quality and Characteristics of Waste Water 44
6. Design of Sewers and Sewerage System 44
7. Treatment of Waste Water 44
8. Air and Noise Pollution 44

Environmental Engineering

1. Water Demand

- 1.1 The population of a city at previous consecutive census year was 4,00,000, 5,58,500, 7,76,000 and 10,98,500. The anticipated population at the next census to the nearest 5,000 would be.....

[1991 : 2 Marks]

2. Quality Characteristics of Water

- 2.1 The pH of water admitted into a treatment plant was 6.0 in the morning. Consequent to inflow of raw water from a different source, it changed to 8.0 in the next 24 hours. Assuming linear variation in time of the hydrogen ion concentration, the time mean pH value of the water over this 24 hour period is.....

[1991 : 1 Mark]

- 2.2 Methemoglobinemia, the 'blue baby' syndrome is caused by consuming water containing excess of

- (a) fluoride (b) phosphate
(c) nitrate (d) nitrite

[1992 : 1 Mark]

- 2.3 Hardness of water is caused by the presence of which of the following in water?

- (a) Chlorides and Sulphates
(b) Calcium and Magnesium
(c) Nitrites and Nitrates
(d) Sodium and Potassium

[1992 : 1 Mark]

- 2.4 Bacteriological examination of drinking water for Escherichia Coliforms (E.Coli) is performed because

- (a) they are pathogenic causing intestinal diseases
(b) their presence indicates viral contamination of water
(c) they are used as indicator organisms for probable presence of pathogens
(d) they represent unique indicator organism for sewage pollution

[1993 : 1 Mark]

3. Water Treatment

- 3.1 The clariflocculator is the unit in which of the following things will occur
- (a) Floc formation and its subsequent removal by filtration
(b) Floc formation and its subsequent removal by sedimentation
(c) Floc formation and its subsequent removal by decantation
(d) Removal of bacteria by filtration and chlorination

[1992 : 1 Mark]

- 3.2 A small filter of 0.05 m depth removes 90% of particles present in water. If the particles removal required is 99%, what should be the depth of filter?

- (a) 0.10 m (b) 0.50 m
(c) 0.75 m (d) 1.00 m

[1992 : 2 Marks]

4. Sources of Water Supply, Distribution System and Well Hydraulics

- 4.1 The volume of water that can be released by gravitational effects from a unit volume of an aquifer is its
- (a) specific storage (b) specific yield
(c) specific capacity (d) specific porosity

[1991 : 1 Mark]

- 4.2 The difference between the free water levels in two wells 48 m apart in an aquifer is 0.6 m. It took an interval of 8 hours between detecting the traces of a tracer material at two wells in succession. The porosity of the aquifer is 25%. The coefficient of permeability of the aquifer is _____ cm/sec.

[1991 : 2 Mark]

- 4.3 The actual volume of water that can be extracted by the force of gravity from a unit volume of aquifer material is known as _____.

[1994 : 1 Mark]

5. Quality & Characteristics of Waste Water

- 5.1 The reoxygenation coefficient K of stream is 0.30 at 20°C. Its K value at 32°C is likely to be.....
[1991 : 1 Mark]
- 5.2 A rapid test to indicate the intensity of pollution in river water is
(a) Biochemical Oxygen Demand
(b) Dissolved Oxygen
(c) MPN
(d) Total Dissolved Solids
[1992 : 1 Mark]
- 5.3 The ultimate BOD of the waste water whose 5 day BOD $(BOD)_5$ and rate constant (base e) are respectively 150 mg/L and 0.23/day is
(a) 80 mg/L (b) 150 mg/L
(c) 180 mg/L (d) 220 mg/L
[1992 : 2 Marks]
- 5.4 High COD to BOD ratio of an organic pollutant represents
(a) high biodegradability of the pollutant
(b) low biodegradability of the pollutant
(c) presence of free oxygen for aerobic decomposition
(d) presence of toxic material in the pollutant
[1993 : 1 Mark]

6. Design of Sewers and Sewerage System

- 6.1 A combined sewer is one which transports
(a) domestic sewage and storm water
(b) domestic sewage and industrial wastes
(c) domestic sewage and over head flow
(d) domestic sewage, industrial wastes and storm water
[1991 : 1 Mark]
- 6.2 A 20 cm diameter sewer is laid at a slope of 0.004 and is designed to carry a discharge at a depth of 10 cm with Manning's $n = 0.014$, the design discharge is.....
[1991 : 2 Marks]

7. Treatment of Waste Water

- 7.1 A township is to treat 5,00,000 litres of sewage per day which has a 5 day BOD of 150 ppm. An oxidation pond is used for the purpose. The effluent can have a BOD of 15 ppm. The loading

is to be 40 kg of 5 day BOD per hectare per day. The required area of the pond is...

[1991 : 2 Marks]

- 7.2 Trickling filters are used to remove
(a) suspended solids
(b) colloidal solids
(c) organic matter
(d) pathogenic bacteria
[1992 : 1 Mark]
- 7.3 Symbiosis, the beneficial association between algae and bacteria is used for treatment of waste water in the following unit?
(a) Activated sludge
(b) Rotating biological disc
(c) Anaerobic digester
(d) Oxidation pond
[1992 : 2 Marks]
- 7.4 Activated sludge is the
(a) aerated sludge in the aeration unit
(b) sludge settled in the humus tank
(c) sludge in the secondary tank after aeration and rich in microbial masses
(d) sludge in the secondary tank after aeration and rich in nutrients
[1993 : 1 Mark]

8. Air and Noise Pollution

- 8.1 In an atmosphere under super-adiabatic lapse rate conditions, the emission from a chimney produces a plume described as
(a) Coning (b) Lofting
(c) Looping (d) Fumigation
[1991 : 1 Mark]
- 8.2 During temperature inversion in atmosphere, air pollutants tend to
(a) accumulate above inversion layer
(b) accumulate below inversion layer
(c) disperse laterally
(d) disperse vertically
[1993 : 1 Mark]



Answers Environmental Engineering

- 1.1 (Sol.) 2.1 (Sol.) 2.2 (c) 2.3 (b) 2.4 (c) 3.1 (b) 3.2 (a) 4.1 (b) 4.2 (Sol.)
 4.3 (Sol.) 5.1 (Sol.) 5.2 (b) 5.3 (d) 5.4 (b) 6.1 (d) 6.2 (Sol.) 7.1 (Sol.) 7.2 (c)
 7.3 (d) 7.4 (c) 8.1 (c) 8.2 (b)

Explanations Environmental Engineering

1. Water Demand

1.1 Sol.

Since the method is not mentioned in the question, hence the question is solved by *incremental increase method*. This is done because

- This method gives results between the results given by the arithmetic increase method and the geometric increase method.
- The method is considered to be the best for any city, whether old or new.

Census year	Population	Population Increment	Incremented Increase
1	4,00,000	1,58,500	59000
2	5,58,500		
3	7,76,000		
4	10,98,500		
		$\bar{X} = \frac{\sum X}{3}$ = 232833.33	$\bar{Y} = \frac{\sum Y}{2}$ = 82000

$$P_n = P_0 + n \cdot \bar{X} + \frac{n(n+1)}{2} \bar{Y}$$

For $n = 1$

$$P_5 = P_0 + 1 \cdot \bar{X} + \frac{1(1+1)}{2} \bar{Y}$$

$$= 10,98,500 + 232833.33 + 82000$$

$$= 1413333.33$$

∴ The anticipated population at the next census to the nearest 5000 would be 1415000.

2. Quality Characteristics of Water

2.1 Sol.

Given, initial pH value = 6.0
 after 24 hour, pH = 8.0

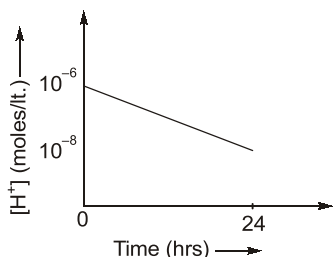

$$[H^+]_{at\ t=0} = 10^{-6}$$

$$[H^+]_{t=24\ hr.} = 10^{-8}$$

$$\therefore \text{Mean of } [H^+] = \frac{10^{-6} + 10^{-8}}{2}$$

$$= \frac{10^{-6}(1 + 10^{-2})}{2}$$

$$= \frac{1.01 \times 10^{-6}}{2}$$

$$= 0.505 \times 10^{-6}$$

So, Mean of pH = $-\log_{10}(0.505 \times 10^{-6})$

$$= -\log_{10}(0.505) + 6$$

$$= 0.2967 + 6 = 6.296$$

2.2 (c)

The nitrates represent the fully oxidized organic matter, and such waters may not be harmful. However, the presence of too much of nitrate in water may adversely affect the health of infants, causing a disease called **methemoglobinemia** called "**blue baby disease**".



POINTS TO REMEMBER

Type	Indication	Permissible limit (mg/l)
1. Free ammonia	Indicates recent pollution.	0.15
2. Organic ammonia	Indicates quantity of nitrogen before decomposition has started.	0.3
3. Nitrite	Indicates partly decomposed condition.	NIL
4. Nitrate	Indicates old population (fully oxidised)	45 mg/l

- Free ammonia + Organic ammonia = K_je[_dah] Ammonia

2.3 (b)

Hardness is caused by the presence of salts of multivalent cations in water. But for all practical purposes, it is attributed to Ca⁺⁺ and Mg⁺⁺ only.

It is because the presence of other cations in most of the waters is generally negligible.

2.4 (c)

Pathogenic bacteria are tested and counted with great difficulty hence coliform bacteria are tested and counted which themselves are harmless aerobic lactose fermenters but their presence or absence indicates the presence or absence of pathogenic bacteria.

3. Water Treatment

3.1 (b)

Clariflocculator is a unit in which the floc formation and its subsequent removal by sedimentation takes place.



POINTS TO REMEMBER

The coagulation sedimentation plant is known as clariflocculator. It consists of 4 units:

- 1. Feeding device:** For addition of waguant into raw water.
- 2. Mixing basin:** For thorough mixing and agitation.
- 3. Flocculation tank:** For consolidation of the flocs formed.
- 4. Sedimentation tank:** For settlement of flocculated particles.

3.2 (a)

Efficiency of small filter is given by

$$\eta = 100(1 - e^{-\lambda d})$$

$$\lambda = \text{constant}$$

$$d = \text{depth of filter}$$

$$\Rightarrow 90 = 100(1 - e^{-\lambda \times 0.05})$$

$$\lambda = 46.05$$

$$\Rightarrow 99 = 100(1 - e^{-46.05 \times d})$$

$$d = 0.1 \text{ m}$$

4. Sources of Water Supply, Distribution System and Well Hydraulics

4.1 (b)

Specific yield is defined as volume of water released under gravity effect to the total volume of water.



POINTS TO REMEMBER

- 1. Specific storage:** It is the volume of water removed from a unit volume of a confined aquifer for a unit drop in hydraulic head [L^{-1}].
- 2. Specific yield:** It is the ratio of volume of water released under gravity effect by saturated soil to the total volume of soil.
- 3. Specific capacity:** It is the discharge per unit drawdown in the well.
- 4. Specific porosity:** Porosity is the fraction of volume of voids over the total volume of a material. And there is no term called as specific porosity.

4.2 Sol.

Seepage velocity,

$$V_s = \frac{\text{Distance between wells}}{\text{Time of tracer}}$$

$$= \frac{48}{8} = 6 \text{ m/hr}$$

$$\text{Also, } V_s = \frac{V}{n}$$

Where, $V =$ discharge velocity

and $n =$ porosity

$$\therefore V = 6 \times 0.25$$

$$\Rightarrow V = 1.5 \text{ m/hr}$$

Now, according to Darcy's law

$$V = ki$$

$$\Rightarrow 1.5 = k \times \left(\frac{h_L}{L} \right)$$

$$\Rightarrow k = 1.5 \times \left(\frac{48}{0.6} \right)$$

$$\Rightarrow k = 120 \text{ m/hr}$$

$$\Rightarrow k = 3.33 \text{ cm/sec}$$

4.3 Sol.

Specific yield.

The **specific yield** of an unconfined aquifer is the ratio of volume of water which will flow under saturated condition due to gravity effect to the total volume of aquifer (V).

5. Quality & Characteristics of Waste Water

5.1 Sol.

$$k_{R(T^\circ\text{C})} = k_{R(20^\circ\text{C})} [1.016]^{T-20^\circ\text{C}}$$

$$= 0.30 (1.016)^{32-20}$$

$$k_{R(32^\circ\text{C})} = 0.36$$

5.2 (b)

Dissolved oxygen is used as an indicator of the health of a water body, where high dissolved oxygen concentration mean high productivity and less pollution.

Test used to measure DO of freshwater systems is Winkler's method. This test is performed on site as delay between sample collection and testing may result in an alteration in oxygen content of sample. Hence it is a rapid test to indicate the intensity of pollution.



REFERENCE MATERIAL

1. For detailed experimental procedure of Winkler's Method, *Environmental Engineering, Vol. 1. SK Garg, CH 15 (Laboratory Experiments)*

5.3 (d)

$$\begin{aligned} \text{BOD}_5 &= L(1 - e^{-kt}) \\ 150 &= L(1 - e^{-0.23 \times 5}) \\ \Rightarrow L &= 219.5 \text{ mg/l} \approx 220 \text{ mg/l} \end{aligned}$$

5.4 (b)

COD corresponds to biodegradable and non-biodegradable while BOD corresponds to biodegradable pollutants. So high COD to BOD ratio implies low biodegradability of the pollutant.

6. Design of Sewers and Sewerage System

6.1 (d)

A combined sewer refers to a single sewer of a larger diameter which transports domestic sewage, industrial wastes and storm water.



POINTS TO REMEMBER

1. It is economical because two separate sets of conduits are required in case of separate sewerage system.
2. During non-monsoon season, silting may take place in combined sewers.
3. In combined sewerage system, the capacity of treatment plant required in more.
4. In case of flooding, more insanitary conditions will prevail in case of combined sewers.

6.2 Sol.

Given, depth of partial flow, $d = 0.10 \text{ m}$

$$\begin{aligned} \therefore d &= \frac{D}{2} \left(1 - \cos \frac{\alpha}{2} \right) \\ \Rightarrow 0.10 &= \frac{0.20}{2} \left(1 - \cos \frac{\alpha}{2} \right) \\ \therefore \alpha &= 180^\circ \end{aligned}$$

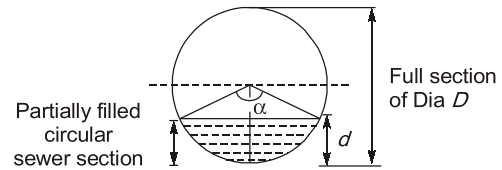

Area of partially filled circular, Sewer section,

$$\begin{aligned} a &= A \left(\frac{\alpha}{360^\circ} - \frac{\sin \alpha}{2\pi} \right) \\ &= \frac{\pi D^2}{4} \left(\frac{\alpha}{360^\circ} - \frac{\sin \alpha}{2\pi} \right) \\ &= \frac{\pi (0.20)^2}{4} \left(\frac{180^\circ}{360^\circ} - \frac{\sin 180^\circ}{2\pi} \right) \\ &= \frac{\pi (0.20)^2}{4} \times \frac{1}{2} \\ &= 0.0157 \end{aligned}$$

$$\begin{aligned} \therefore \text{Design discharge,} \\ q &= av \\ &= a \cdot \frac{1}{n} \cdot (r)^{2/3} \cdot (s)^{1/2} \quad \dots \text{(iii)} \end{aligned}$$

Now, $\frac{p}{P} = \frac{\alpha}{360^\circ}$ and $\frac{r}{R} = \frac{a/P}{A/P}$

$$\Rightarrow \frac{r}{R} = \frac{a}{A} \times \frac{P}{p}$$

$$\Rightarrow \frac{r}{R} = \left[1 - \frac{360^\circ \sin \alpha}{2\pi \alpha} \right]$$

$$\begin{aligned} \Rightarrow r &= R \left[1 - \frac{360^\circ \sin 180^\circ}{2\pi \times 180^\circ} \right] \\ &= R = \frac{D}{4} = \frac{0.20}{4} = 0.05 \end{aligned}$$

$$\begin{aligned} \therefore \text{Design discharge,} \\ q &= a \cdot v \\ &= a \cdot \frac{1}{n} \cdot (r)^{2/3} \cdot (s)^{1/2} \end{aligned}$$

$$\begin{aligned} \therefore q &= 0.0157 \times \frac{1}{0.014} (0.05)^{2/3} (0.004)^{1/2} \\ &= 9.626 \times 10^{-3} \text{ m}^3/\text{sec} = 9.626 \text{ lit/sec} \end{aligned}$$

7. Treatment of Waste Water

7.1 Sol.

Sewage produced = 500000 lit/day
 5 day B.O.D of sewage = 150 mg/lit
 B.O.D. of effluent = 15 mg/lit
 B.O.D. removed by pond
 $= (150 - 15) = 135 \text{ ppm}$
 \therefore Sewage removed, per day
 $= 5,00,00 \times 135 \text{ mg}$
 $= 67.5 \times 10^6 \text{ mg} = 67.5 \text{ kg}$
 It is given that organic loading
 $= 40 \text{ kg/Ha/day}$

$$\begin{aligned} \therefore \text{Required area} &= \frac{\text{Sewage consumed}}{\text{organic loading}} \\ &= \frac{67.5}{40} = 1.6875 \text{ Ha} \end{aligned}$$

7.2 (c)

The **trickling fillers** are now almost universally adopted for giving secondary treatment to sewage. These are used to remove the organic matter present in the sewage.

7.3 (d)

- In oxidation pond, the algae (which are microscopic plants) while growing in the presence of sunlight produce oxygen by the action of photosynthesis, and this oxygen is utilized by bacteria for oxidizing the waste organic matter.
- The end products of organic matter oxidized by bacteria (viz. CO_2 , NH_3 , PO_4 , H_2O) are required by algae to grow and produce oxygen.
- Hence, there exist a beneficial association between algae and bacteria, known as symbiotic relationship.

7.4 (c)

The settled sludge, secondary settling tank, contains a large concentration of highway active aerobic micro-organisms, hence it is known as

activated sludge.

A portion of activated sludge is recycled to the head of the aeration tank to be mixed again with the sewage being treated.

8. Air and Noise Pollution

8.1 (c)

(i) Looping plume

Occurs in super adiabatic environment. Which produces highly unstable environment because of rapid mixing.

Higher stacks are needed.

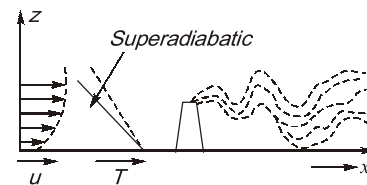

(ii) Neutral plume

Upward vertical rise when $\text{ELR} = \text{ALR}$

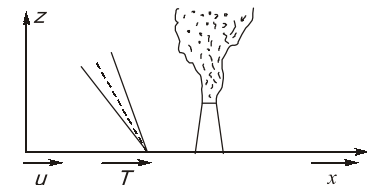

(iii) Coning plume

When wind velocity $> 32 \text{ km/hr}$ & when clouds are present.

Also occurs under sub-adiabatic condition. ($\text{ELR} < \text{ALR}$)

Environment is **slightly stable**.

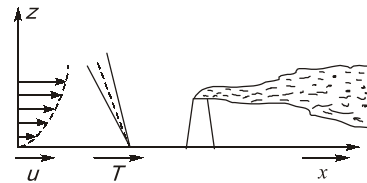

(iv) Fanning plume

Under extreme inversion conditions Emission will spread only horizontally High rising stacks are needed.

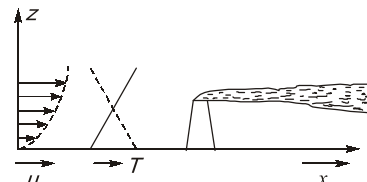

(v) Lofting plume

When there exists a strong super adiabatic L.R. above surface inversion.

Such plume has minimum downward mixing as its downward motion is prevented by inversion but upward mixing will be rapid and turbulent.

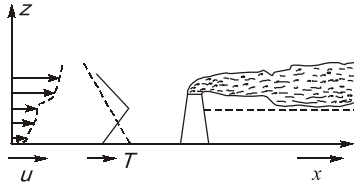
**(vi) Fumigating plume**

When inversion layer occurs at a short distance above the top of the stack and super adiabatic conditions prevail below the stack. Pollutants can not escape above the top of the stack because of inversion layer.

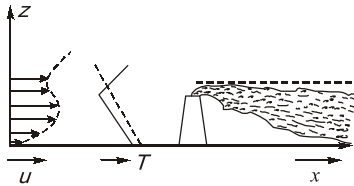
**(vii) Trapping plume**

When inversion layer exists above the emission source as well as below the source. Naturally the emitted plume will neither go up nor down.

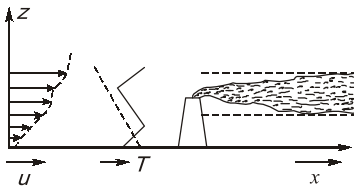
**POINTS TO REMEMBER**

- **ELR:** The Environment Lapse Rate (ELR), is the rate of decrease of temperature with altitude in the stationary atmosphere at a given time and location.
- **ALR:** When a pocket of artificially heated air (i.e., automobile exhaust or stack gas) is emitted into the environment it rises up, expands, becomes lighter and gets cooled. This internal temperature change (decrease) which occurs within the rising parcel can be theoretically calculated by assuming the cooling process to be adiabatic. This rate of decrease of temperature with height is called adiabatic lapse rate.

8.2 (b)

When the temperature of the environment increases with altitude, then the lapse rate becomes inverted or negative from its normal state. Negative lapse rate occurs under condition, usually referred to as inversion, a state in which the warmer air lies over the colder air below. The radiation inversion is a phenomenon occurring from the unequal cooling rates for the earth and air above the earth. Such an inversion in the environment helps in formation of fog when air is wet, and simultaneously catches gases and particulate matter, as it stops their upward lifting, thereby creating concentration of pollutants in our close environment.



CONTENTS

1. Design of Stable Channels 51
2. Design & Construction of Gravity Dams 51
3. Theories of Seepage, Spillways
and Miscellaneous 51

Irrigation Engineering

1. Design of Stable Channels

- 1.1 Lacey's scour depth for a stream carrying a discharge of 3 cumecs per meter width having a silt factor 1.2 is

[1992 : 2 Marks]

2. Design & Construction of Gravity Dams

- 2.1 The live storage requirement for a reservoir is to be determined by
- topographical survey
 - annual demand
 - double mass curve analysis
 - mass curve analysis

[1993 : 1 Mark]

3. Theories of Seepage, Spillways and Miscellaneous

- 3.1 In a syphon aqueduct, the most severe condition of uplift on the floor occurs when
- the canal and drainage run full
 - the canal runs full; the drainage channel is dry, and the water table is at the stream bed
 - the canal is dry, the drainage floor is at HFL and the water table is at the HFL of the drainage flow
 - the canal runs full; and the drainage is dry

[1991 : 1 Mark]

- 3.2 For the head regulator, the most severe condition of uplift pressure on the floor occurs when
- the flow in the river is at flood level and canal is running at full supply depth
 - the canal runs empty and the river flow is at high flood level
 - the canal runs at full supply depth and the river flow is at pond level
 - the canal runs dry and the river flow is pond level

[1992 : 1 Mark]

- 3.3 In connection with the design of a barrage, identify the correct matching of the criteria of design (A), (B), (C), (D) for the items of design (i), (ii), (iii), (iv) respectively

Item of design

- Width of waterway
- Level and length of downstream floor
- Depth of downstream sheet piles and total length of floor
- Barrage floor thickness at different locations

Criteria of Design

- Hydraulic jump considerations
 - Lacey's wetted perimeter and discharge capacity of the barrage as determined by appropriate weir formulae
 - Uplift pressure distribution as determined by Khosla's theory
 - Lacey's scour depth and exit hydraulic gradient as given by Khosla's theory
- (a) A, B, C, D (b) A, B, D, C
(c) B, A, D, C (d) B, A, C, D

[1993 : 2 Marks]

- 3.4 When a canal is passed under the drainage such that the full supply level of the canal does not touch the underside of the supporting structure, the cross drainage work is called a

[1994 : 1 Mark]

- 3.5 The ratio of the rate of change of discharge of an outlet to rate of change of discharge of the parent channel is defined as

[1994 : 1 Mark]



Answers Irrigation Engineering

1.1 Sol. 2.1 (a) 3.1 (c) 3.2 (b) 3.3 (c) 3.4 (Sol.) 3.5 (Sol.)

Explanations Irrigation Engineering**1. Design of Stable Channels****1.1 Sol.**

Lacey's scour depth,

$$R = 1.35 \left(\frac{q^2}{f} \right)^{1/3} = 1.35 \left(\frac{3^2}{1.2} \right)^{1/3} = 2.6425 \text{ m}$$

2. Design & Construction of Gravity Dams**2.1 (a)**

To find the storage requirement or volume to be present in any reservoir, a plot of accumulated supply vs. time is superimposed with accumulated demand vs. time.

The storage requirements and the depletions from the storage are then analysed with the help of this mass curve.

Refer: Design of balancing reservoir in environmental engineering.

3. Theories of Seepage, Spillways and Miscellaneous**3.1 (c)**

Syphon aqueduct can be accomplished by passing the canal over the drainage. If HFL of drain is sufficiently below the bottom of canal, so drainage water flows freely under gravity, the structure is known as aqueduct. But if HFL of drain is higher than canal bed and water passes through aqueduct barrels under syphonic action, the structure is known as **syphon aqueduct**.

Hence most **severe condition** of uplift on floor occurs when:

Canal is dry and drainage floor is at HFL and water table is at HFL of drainage flow. Because at this condition downward force on floor due to canal flow is minimum and upward force on floor due to

syphonic action of drain will be maximum.

3.2 (b)

A head regulator receives water from parent and allows the water to an offtake. Observing this case, the parent is river and the offtake is main canal.

Worst condition of uplift will be due to maximum head causing the flow which will be obtained in case (b).

3.3 (c)

1. Width of waterway is obtained by Lacey's wetted perimeter, which is given by

$$P = 4.75\sqrt{Q}$$

2. Level and length of downstream floor is decided according to the characteristics of hydraulic jump.

3. Depth of sheet piles must be upto the level of scour depth below the river bed.

4. Barrage floor thickness should be sufficient to counteract the uplift pressure

3.4 Sol.

Super passage (Standard term)

3.5 Sol.

Flexibility of outlet

$$F = \frac{dq/q}{dQ/Q}$$

Where

q is discharge through the outlet

Q is discharge parent

**POINTS TO REMEMBER**

1. Proportionality: Outlet is said to be proportional when the rate of change of outlet discharge equals the rate of change of channel discharge

i.e., Flexibility, $F = \frac{dq/q}{dQ/Q} = 1$

2. Senitivity (S): It is the ratio of rate of change of discharge through an outlet to the rate of change of the water surface level of distributory channel w.r.t. the normal depth of the flow in the channel.

i.e., $S = \frac{dq/q}{dG/y}$

Where G = Gauge reading ($G = 0$ when $q = 0$)



CONTENTS

1. Precipitation and General Aspects
of Hydrology 55
2. Floods, Flood Routing and Flood Control 55

Engineering Hydrology

1. Precipitation and General Aspects of Hydrology

- 1.1 A tropical cyclone in a northern hemisphere is a wind stream with
- (a) high pressure zone of anti-clockwise rotation
 - (b) high pressure zone of clockwise rotation
 - (c) low pressure zone of anti-clockwise rotation
 - (d) low pressure zone of clockwise rotation
- [1991 : 1 Mark]
- 1.2 The ratio of total channel length to the discharge area is called
- [1994 : 1 Mark]
- 1.3 The Thiessen polygon is
- (a) a polygon obtained by joining adjoining raingauge stations
 - (b) a representative area used for weighing the observed station precipitation
 - (c) used in the construction of depth area curves
 - (d) the descriptive term for shape of a hydrograph
- [1994 : 1 Mark]

2. Floods, Flood Routing and Flood Control

- 2.1 The standard project flood is
- (a) same as the probable maximum flood
 - (b) same as the design flood
 - (c) smaller than the probable maximum flood
 - (d) larger than the probable maximum flood by a factor implying safety factor
- [1991 : 1 Mark]
- 2.2 Dickens formula predicts maximum flood discharge, Q , in terms of the area, A , and the coefficient, c , as $Q = cA^n$. The value of n is
- (a) 0.25
 - (b) 0.50
 - (c) 0.67
 - (d) 0.75
- [1992 : 1 Mark]
- 2.3 Match the following:

- (a) Coriolis coefficient
 - (b) Khosla's curves
 - (c) Gumbel's method
 - (d) Manning's coefficient
1. Perched aquifer
 2. Prediction of flood peaks
 3. Weirs and barrages
 4. Velocity distribution
 5. Open channel flow

[1992 : 2 Marks]

- 2.4 The design flood for a culvert should be preferably
- (a) the probable maximum flood
 - (b) obtained from statistical considerations, say a flood of 50 years return period
 - (c) the highest observed flood
 - (d) obtained from a flood formula
- [1993 : 1 Mark]
- 2.5 A temporary coffer dam is to be built to protect the 5 year construction activity for a major cross valley dam. If the coffer dam is designed to withstand the 20 year flood, the risk that the structure will be over topped in the third year exactly is

[1994 : 1 Mark]

- 2.6 A linear reservoir is one-in which
- (a) the volume varies linearly with elevation
 - (b) the storage varies linearly with time
 - (c) the storage varies linearly with the outflow rate
 - (d) the storage varies linearly with the inflow rate

[1994 : 1 Mark]

Answers Engineering Hydrology

1.1 (c) 1.2 (Sol.) 1.3 (b) 4.1 (c) 4.2 (d) 4.3 (Sol.) 4.4 (b) 4.5 (Sol.) 4.6 (c)

Explanations Engineering Hydrology**1. Precipitation and General Aspects of Hydrology****1.1 (c)**

Tropical cyclone has low pressure at its eye, and due to **CORIOLIS** force it tends to have anticlockwise rotation in Northern Hemisphere.

1.2 Sol.

Drainage density.

1.3 (b)

Thiessen Polygon Method: In this method the rainfall recorded at each station is given a weightage on the basis of an area closest to the station.

$$P_{avg} = \frac{P_1 A_1 + P_2 A_2 + \dots + P_n A_n}{A_1 + A_2 + \dots + A_n}$$

where, P_1, P_2, \dots, P_n are the rainfall data of areas $A_1, A_2 \dots A_n$.

The Thiessen-polygon method of calculating the average precipitation over an area is superior to the arithmetic average method.

2. Floods, Flood Routing and Flood Control**2.1 (c)**

The standard project flood is the flood that would result from a severe combination of meteorological and hydrological factors. It is smaller than probable maximum flood (PMF).

Standard project flood \simeq 40-60% of PMF.

2.2 (d)

Dickens formula is given by,

$$Q_p = C_D A^{3/4}$$

Where, A = Catchment area in km^2

C_D = Dicken's constant,

$$6 \leq C_D \leq 30$$

$$\therefore n = \frac{3}{4} = 0.75$$

**POINTS TO REMEMBER**

$$Q_p \propto A^n$$

- Inglis formula : $n = 0.5$
- Ryve's formula: $n = 0.67$
- Diken's formula: $n = 0.75$

2.3 Sol.

(A- 4 : B-3 : C-2 : D-5)

- **Coriolis coefficient** is used to account for the effect of a non-uniform velocity distribution.
- **Khosla's curve** is used for design of weir and barrages on permeable foundation.
- **Gumbel's method** is used for estimation of design flood for a particular return period.
- **Manning's equation** is used to measure velocity in open channel flow.

2.4 (b)

Design Flood: The design flood for a structure such as a bridge or culvert is the flow that the structure must be designed to pass safely. It is specific to the location of the proposed structure and it is usually specified by its '**return period**'.

2.5 Sol.

Probability of occurrence,

$$P = \frac{1}{T} = \frac{1}{20}$$

$$\text{Probability of non-occurrence} = 1 - \frac{1}{20} = \frac{19}{20}$$

\therefore Risk that the structure will be overlapped in exactly third years

$$\begin{aligned} &= \frac{19}{20} \times \frac{19}{20} \times \frac{1}{20} \\ &= 0.0451 = 4.51\% \end{aligned}$$



Transportation Engineering

UNIT

X

CONTENTS

1. Highway Geometric Design & Planning 58
2. Traffic Engineering 58
3. Highway Materials 58
4. Pavement Design 58

Transportation Engineering

1. Highway Geometric Design & Planning

- 1.1 Transition curve is provided in horizontal alignment
- (a) to increase the radius of curvature
 - (b) to facilitate the application of superelevation
 - (c) to counteract the centrifugal force developed
 - (d) to prevent vehicle from skidding laterally
- [1991 : 1 Mark]
- 1.2 If the design speed is 80 kmph, perception reaction time 3 seconds and coefficient of friction 0.5, the safe stopping sight distance is.....
- [1991 : 2 Marks]
- 1.3 Given the sight distance as 120 m, the height of the driver's eye as 1.5 m, the height of the obstacle as 15 cm and the grade difference of the intersecting gradients as 0.09, the required length of the summit parabolic curve is
- [1991 : 2 Marks]
- 1.4 The important factor considered in the design of summit curves on highways is
- (a) comfort to passenger
 - (b) sight distance
 - (c) superelevation
 - (d) impact factor
- [1992 : 1 Mark]
- 1.5 The superelevation needed on a horizontal circular curves of 150 m radius for a design speed of 60 kmph with a coefficient of friction 0.15 is
- [1992 : 2 Marks]
- 1.6 A road is passing through a hilly area with horizontal curve. If the superelevation provided is 1 in 10 and the coefficient of lateral friction is 0.16, the minimum radius of the horizontal curve which the vehicles can negotiate safely at a speed of 40 kmph in metres is
- [1993 : 2 Marks]

2. Traffic Engineering

- 2.1 Moving car observer method is a procedure

- (a) to find the traffic flow of traffic stream
- (b) to estimate the traffic capacity of a road section
- (c) to carry out origin destination studies
- (d) to identify accident prone locations on highway

[1991 : 1 Mark]

- 2.2 Desire lines are drawn based on

- (a) spot speed studies
- (b) traffic volume studies
- (c) accident studies
- (d) origin and destination studies

[1992 : 1 Mark]

- 2.3 The PCU (passenger car unit) value for car on an urban road is

- (a) 0.5
- (b) 1.0
- (c) 3.0
- (d) 4.0

[1992 : 1 Mark]

3. Highway Materials

- 3.1 The result of ring and ball softening point test on asphalts is given in terms of
- (a) viscosity
 - (b) time
 - (c) flow
 - (d) temperature
- [1991 : 1 Mark]
- 3.2 The temperature to be maintained for the determination of the penetration value of bitumen is
- (a) 15°C
 - (b) 25°C
 - (c) 40°C
 - (d) 60°C
- [1992 : 1 Mark]

4. Pavement Design

- 4.1 California Bearing Ratio (CBR)
- (a) is a measure of soil strength
 - (b) is a procedure for designing flexible pavements
 - (c) is a method of soil identification
 - (d) is a measure to indicate the relative strengths of paving materials

[1991 : 1 Mark]

- 4.2** The position of base course in a flexible pavement is
 (a) over the sub-base
 (b) below the sub-base
 (c) over the sub-grade but below the sub-base
 (d) over the wearing course when renewal of surface is needed
 [1991 : 1 Mark]
- 4.3** The Modulus of Subgrade Reaction is evaluated from
 (a) plate bearing test (b) CBR test
 (c) direct shear test (d) triaxial test
 [1992 : 1 Mark]
- 4.4** The load transfer to lower layers in flexible pavements is by
 (a) bending action of layers
 (b) shear deformation
 (c) grain to grain contact
 (d) consolidation of subgrade
 [1992 : 1 Mark]
- 4.5** For laying bituminous carpet over water bound macadam road surface, one has to apply a
 (a) tack coat (b) seal coat
 (c) bitumen grout (d) slurry coat
 [1992 : 1 Mark]
- 4.6** In a cement concrete pavement dowel bars are used in
 (a) longitudinal joints
 (b) construction joints
 (c) dummy joints
 (d) expansion joints
 [1992 : 1 Mark]
- 4.7** A contraction joint is provided in concrete pavement to
 (a) prevent contraction of the pavement
 (b) permit cracking at the joint
 (c) lower the bending moment in the pavement in order to reduce pavement thickness
 (d) lower the temperature gradient across the depth of the pavement
 [1993 : 1 Mark]
- 4.8** A plate bearing test was carried out on a subgrade using a 76 cm diameter rigid plate. A deflection of 1.25 mm was caused by a pressure of 0.84 kg/cm². The modulus of subgrade reaction in kg/cm³ is
 [1993 : 2 Marks]

Answers Engineering Hydrology

- 1.1 (b) 1.2 (Sol.) 1.3 (Sol.) 1.4 (b) 1.5 (Sol.) 1.6 (Sol.) 2.1 (a) 2.2 (d) 2.3 (b)
 3.1 (d) 3.2 (b) 4.1 (d) 4.2 (a) 4.3 (a) 4.4 (c) 4.5 (a) 4.6 (d) 4.7 (b)
 4.8 (Sol.)

Explanations Engineering Hydrology

1. Highway Geometric Design & Planning

1.1 (b)

Transition curve is provided in horizontal alignment to

- (i) introduce gradually the centrifugal force between the tangent point and the beginning of the circular curve, avoiding a sudden jerk on the vehicle.
- (ii) enable the driver turn the steering for his own comfort and security.
- (iii) enable gradual introduction of the designed superelevation and extra widening of pavement

- at the start of the circular curve.
 (iv) improve the aesthetic appearance of the road.



POINTS TO REMEMBER

Superelevation is provided to counteract centrifugal force. The transition curve facilitates gradual introduction of superelevation. So, the appropriate answer is option (b)

1.2 Sol.

Stopping sight distance,

$$SSD = (0.278Vt) + \frac{v^2}{254f}$$

Here, $V = 80 \text{ km/hr}$
 reaction time, $t = 3 \text{ sec}$
 coefficient of friction,
 $f = 0.50$

$$\therefore \text{SSD} = (0.278 \times 80 \times 3) + \frac{(80)^2}{254 \times 0.50}$$

$$= 66.72 + 50.39 = 117.11 \text{ m}$$

1.3 Sol.

Let, length of summit curve is greater than sight distance.

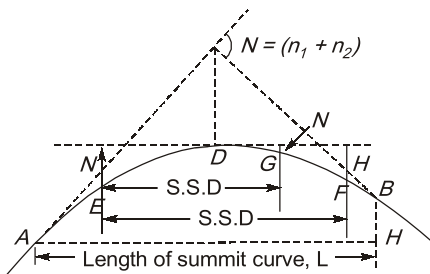

\therefore length of summit parabolic curve,

$$L_{sc} = \frac{NS^2}{(\sqrt{2H} + \sqrt{2h})^2}$$

$$= \frac{0.09 \times (120)^2}{(\sqrt{2 \times 1.50} + \sqrt{2 \times 0.15})^2}$$

$$= 249.36 \text{ m} > \text{sight distance}$$

Hence our assumption is correct.

so, length of summit curve is 249.36 m.

**POINTS TO REMEMBER**

- For SSD calculations, the driver's eye is assumed as 1.2 m and the height of the obstacle is taken as 15 m.

**AVOID MISTAKE**

$$L_{sc} = \frac{NS^2}{4.4} = 0.09 \times \frac{120^2}{4.4}$$

$$= 294.55 \text{ m} > \text{SSD (120 m)}$$

This answer is for standard case of $H = 1.2 \text{ m}$ and $h = 0.15 \text{ m}$.

1.4 (b)

In case of summit curves, when a fast moving vehicle travels along a summit curve, the centrifugal force will act upwards, against gravity

and hence a part of the pressure on tyres and springs of vehicle suspensions is relieved. So there is no problem of discomfort of passengers on summit curves.

The only problem in designing summit curves is to provide adequate sight distance. The stopping sight distance or the absolute minimum sight distance should invariably be provided at all sections of the road system and also on summit curves.

Also members, the valley curves are designed as per comfort condition and headlight sight distance criteria.

1.5 Sol.

Design of superelevation:

$$e_{\text{equilibrium}} = \frac{(0.75V)^2}{gR}$$

$$e_{\text{eq}} = \frac{\left(0.75 \times \frac{60}{3.6}\right)^2}{9.81 \times 150}$$

$$e_{\text{eq}} = 0.1062 > 0.07$$

Provide, $e = 0.07$ and check for friction

$$\Rightarrow 0.07 + f = \frac{V^2}{gR}$$

$$\Rightarrow 0.07 + f = \frac{\left(\frac{60}{3.6}\right)^2}{9.81 \times 150}$$

$$\therefore f = 0.118 < 0.15 \quad (\text{OK})$$

Hence, provide superelevation = 0.07

1.6 Sol.

$$e = \frac{1}{10} = 0.1$$

$$f = 0.16$$

$$V = 40 \text{ kmph}$$

$$\text{Now, } e + f = \frac{V^2}{gR}$$

If V is in km/hr, then,

$$\Rightarrow e + f = \frac{V^2}{127R}$$

$$\Rightarrow 0.1 + 0.16 = \frac{(40)^2}{127R}$$

Solving, we get

$$R = 48.45 \text{ m}$$

2. Traffic Engineering

2.2 (d)

The origin and destination study provides the basic data for determining the desired directions of flow. On the basis of these studies, desire lines are drawn. Thickness of desire lines is directly proportional to the traffic between the two points.

2.3 (b)

The PCU may be considered as measure of the relative space requirement of a vehicle class compared to that of a passenger car under a specified set of roadway, traffic and other conditions. If the addition of one vehicle of a particular class in the traffic stream produces the same effect as that due to addition of one passenger car, then that vehicle class is considered equivalent to the passenger car with a PCU value equal to 1.0

3. Highway Materials

3.1 (d)

The **ring and ball test** is usually useful for determining the softening point of bitumen and softening point is the temperature at which substance attains a particular degree of softening under specified conditions.

3.2 (b)

The **penetration test** determines the hardness or softness of bitumen by measuring the depths in tenths of a millimetre to which a standard loaded needle will penetrate vertically in five seconds. The sample is maintained at a temperature of 25°C.

4. Pavement Design

4.1 (d)

CBR is a measure to indicate the relative strengths of paving materials.



POINTS TO REMEMBER

- California bearing ratio represents the strength of paving materials in terms of crushed californian which has a CBR value of 100.
- CBR value can also be greater than 100 for well-compacted areas.

4.2 (a)

Flexible pavements are those, which on the whole have low or negligible flexural strength and are rather flexible in their structural action under the loads.

A typical **flexible pavement** consists of four components : 1. soil subgrade 2. sub-base course 3. base course 4. surface course as shown in figure.

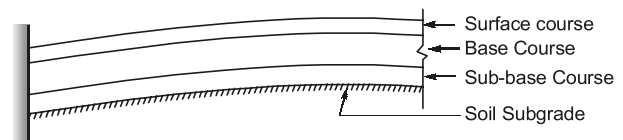

4.3 (a)

The **plate bearing test** is used to determine the supporting power of subgrade for use in pavement design by using relatively larger diameter plates. The **plate bearing test** was originally devised to find the modulus of subgrade reaction in the Westergaard's analysis for wheel load stress in cement concrete pavements.

4.4 (c)

The flexible pavement layers transmit the vertical or compressive stress to the lower layers by grain to grain transfer through the points of contact in the granular structure.

On the other hands, load transfer in rigid pavement occurs by layer to layer transfer by bending action.

4.5 (a)

Bituminous tack coat is the application of bituminous material over an existing pavement surface which is relatively impervious like an existing bituminous surface or a cement concrete pavement or a pervious surface like the WBM which has already been treated by a prime coat.

4.6 (d)

Dowel bars are provided at expansion joints and sometimes at contraction joints also to facilitate load transfer. Longitudinal joints in cement concrete pavements are constructed with suitable tie bars.

4.7 (b)

Contraction joints are provided to permit the contraction of the slab and regulate the position of crack. The slab is weakened at certain locations (contraction joints). So cracking occurs at these pre-determined locations.

4.8 Sol.

The modulus of subgrade reaction for 76 cm diameter rigid plate,

$$k_1 = \frac{P}{\Delta} = \frac{0.84 \text{ kg}}{0.125 \text{ cm}^3} \\ = 6.72 \text{ kg/cm}^3$$

\therefore Modulus of sub-grade reaction for standard plate of radius 75 cm,

$$k = \frac{k_1 a_1}{a} = \frac{6.72 \times 76}{75} \\ = 6.81 \text{ kg/cm}^3$$

**POINTS TO REMEMBER**

- Westergaard defined modulus of subgrade reaction as:

$$k = \frac{p}{\Delta}$$

where, Δ is deflection (taken as 0.125 cm)

p is pressure sustained by the rigid of diameter 75 cm at a deflection of 0.125 cm.



CONTENTS

1. Fundamental Concepts of Surveying and
Linear Measurement 64
2. Compass and Traverse Surveying 64
3. Levelling and Contouring 64
4. Tacheometric, Curve, Hydrographic and
Plane Table Surveying & Theory of Errors 64

Geomatics Engineering

1. Fundamental Concepts of Surveying and Linear Measurement

- 1.1 The required slope correction for a length of 60 m, along a gradient of 1 in 20 is
(a) 7.50 cm (b) 75.0 cm
(c) 0.75 cm (d) 5.50 cm
[1990 : 2 Marks]

- 1.2 The length of a base line measured on ground at an elevation of 300 metres above mean sea level is 2250 metres. The required correction to reduce to sea level length (given the radius of earth is 6370 km) is _____
[1991 : 2 Marks]

- 1.3 A line measured on a uniform slope with a 30 m tape pulled with a force of 5 kg. The length of the line was found to be 525.80 m. The temperature at the time of measurement was 30°C and the tape is correct at 24°C when there is no pull. Determine the horizontal distance between the end points of the line. The difference of levels of the two ends of the line is 9.14 m. The coefficient of thermal expansion of the material of the tape is 0.00001 per °C. Cross-sectional area of the tape is 2 mm² and its modulus of elasticity is 21×10^5 kg/cm².
[1993 : 2 Marks]

2. Compass and Traverse Surveying

- 2.1 True meridians at different places coverage
(a) from South Pole to North Pole
(b) 187 from equator to North and South Pole
(c) from North Pole to South Pole
(d) None of the above
[1990 : 2 Marks]

- 2.2 Two points P and Q located on a map have the following coordinates

	P	Q
Latitude (L)	+40 m	+20 m
Departure (D)	-20 m	+30 m

The length of PQ is _____

- (a) 53.85 m (b) 34.89 m
(c) 34.98 m (d) 12.89 m

[1991 : 2 Marks]

- 2.3 The quadrantal bearings of the lines AB and CA are 530°E and 570°E. The included angle CAB is _____
[1991 : 2 Marks]

3. Levelling and Contouring

- 3.1 While levelling in an undulating terrain, it is preferable to set up the instrument on
(a) the top of summit
(b) the bottom of a valley
(c) one side of the slope
(d) a flat location
[1992 : 1 Mark]

- 3.2 The rise and fall method provides an arithmetic check on
(a) back sights and fore sights
(b) intermediate sights
(c) back sights and intermediate sights
(d) back sights, intermediate sights and fore sights
[1992 : 1 Mark]

- 3.3 A line of levels has been run from a bench mark of elevation 23.47 m and ends at another bench mark of elevation 23.50 m. The sum of the Backsights is 16.26 m and that of the Foresights is 16.29 m. The closing error is.....
[1993 : 2 Marks]

4. Tacheometric, Curve, Hydrographic and Plane Table Surveying & Theory of Errors

- 4.1 The resected position of plane table station from three known positions is unreliable, if the station lies _____
[1990 : 1 Mark]

- 4.2 Setting out a curve using two theodolite methods involves with

- (a) Linear measurements only
- (b) Angular measurements only
- (c) One linear and one angular measurements
- (d) One linear and two angular measurements

[1990 : 1 Mark]

4.3 Systematic errors are those errors

- (a) whose effects are cumulative and can be determined
- (b) on circumference of circumscribing circle
- (c) outside the great triangle
- (d) in the centre of the circumscribing circle

[1990 : 2 Marks]

4.4 Tilt of the staff in tachometric survey increases the intercept if it is

- (a) away from the telescope pointing up the hill
- (b) towards the telescope pointing up the hill
- (c) away from the telescope pointing down the hill
- (d) None of above

[1990 : 2 Mark]

4.5 The tangent distance for a circular curve of length 150 metres joining two straights meeting at an external deflection angle of 30° is _____

[1991 : 2 Mark]

4.6 Anallactic lens provided in a tacheometer is a

- (a) concave lens
- (b) convex lens
- (c) plano-convex lens
- (d) plane lens

[1992 : 1 Mark]

4.7 The tangential method of tacheometry is

- (a) slower than stadia hair method
- (b) faster than stadia hair method
- (c) preferred as involves less computations to get reduced distances
- (d) preferred as chances of operational error are less compared to stadia hair method

[1992 : 1 Mark]

4.8 The following observations of an angle 'P' are made as $P = 30^{\circ}28'40''$, $3P = 91^{\circ}25'55''$, $4P = 121^{\circ}54'30''$

The most probable value of a angle 'P' is

- (a) 1 : 900
- (b) 1 : 1111
- (c) 1 : 1121
- (d) 1 : 1221

[1992 : 2 Marks]

Answers Geomatics Engineering

- 1.1 (a) 1.2 (Sol.) 1.3 (Sol.) 2.1 (b) 2.2 (a) 2.3 (Sol.) 3.1 (c) 3.2 (d)
 3.3 (Sol.) 4.1 (Sol.) 4.2 (b) 4.3 (a) 4.4 (a) 4.5 (Sol.) 4.6 (b) 4.7 (a) 4.8 (b)

Explanations Geomatics Engineering

1. Fundamental Concepts of Surveying and Linear Measurement

1.1 (a)

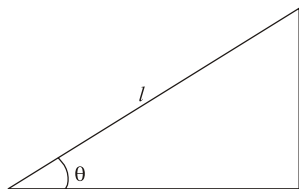

$L = 60 \text{ m}$

$\tan \theta = \frac{1}{20}$

$\Rightarrow \cos \theta = 0.9988$

Slope correction = $L (1 - \cos \theta)$

Where L = Measured distance

Hence,

Slope correction = $60(1 - 0.9988)$
 $= 7.49 \text{ cm} \approx 7.5 \text{ cm}$

Note: Slope correction is always negative.

1.2 Sol.

Mean sea level correction, $C_h = -\frac{hL}{R}$

Where

R = Radius of earth

h = Altitude above MSL

L = Measured length

$\therefore C_h = -\frac{2250 \times 300}{6370 \times 1000} = -0.106 \text{ m}$

1.3 Sol.

Temperature correction

$$\begin{aligned}
 &= L \propto (T - T_0) \\
 &= 525.80 \times 0.00001 \times (30 - 24) \\
 &= 0.0315 \text{ m}
 \end{aligned}$$

Pull correction

$$\begin{aligned}
 &= \frac{(P - P_0)L}{AE} \\
 &= \frac{(5 - 0) \times 525.80}{(2 \times 10^{-2}) \times 21 \times 10^5} \\
 &= 0.0626 \text{ m}
 \end{aligned}$$

Slope correction

$$= -L (1 - \cos \theta)$$

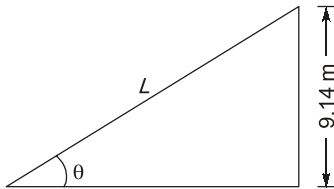

$$\therefore \sin \theta = \frac{9.14}{525.80}$$

$$\Rightarrow \theta = 0^\circ 59' 45.69''$$

Hence, slope correction

$$\begin{aligned}
 &= -525.80 (1 - \cos 0^\circ 59' 45.69'') \\
 &= -0.0795 \text{ m}
 \end{aligned}$$

$$\therefore \text{Total correction} = 0.0146 \text{ m}$$

$$\therefore \text{Correct horizontal distance}$$

$$\begin{aligned}
 &= 525.8 + 0.0146 \\
 &= 525.8146 \text{ m}
 \end{aligned}$$

2. Compass and Traverse Surveying**2.1 (b)**

For small surveys, true meridians at different places are assumed to be parallel to each other. In actual, they converge from equator to North and South Pole.

2.2 (a)

Length of PQ,

$$\begin{aligned}
 L &= \sqrt{(L_P - L_Q)^2 + (D_P - D_Q)^2} \\
 &= \sqrt{(40 - 20)^2 + (-20 - 30)^2} \\
 &= 53.85 \text{ m}
 \end{aligned}$$

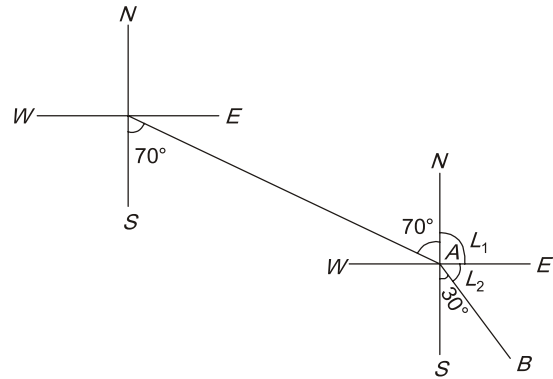
2.3 Sol.

$$\begin{aligned}
 L_1 &= 90^\circ \\
 (L_2 + 30) &= 90^\circ \\
 \Rightarrow L_2 &= 60^\circ \\
 \text{Now, } \angle CAB &= 70^\circ + L_1 + L_2 \\
 &= 70^\circ + 90^\circ + 60^\circ \\
 &= 220^\circ
 \end{aligned}$$

3. Levelling and Contouring**3.2 (d)**

$$\Sigma BS - \Sigma FS = \Sigma \text{Rise} - \Sigma \text{Fall} = \text{Last RL} - \text{First RL}$$

As $\Sigma \text{Rise} - \Sigma \text{Fall}$ also provide check on intermediate sight.

Hence, this provides a complete check on intermediate sights also.

3.3 Sol.

$$\begin{aligned}
 \Sigma BS - \Sigma FS &= 16.26 - 16.29 \\
 &= -0.03 \text{ m}
 \end{aligned}$$

$$\begin{aligned}
 \text{Last RL} - \text{First RL} &= 23.50 - 23.47 \\
 &= 0.03 \text{ m}
 \end{aligned}$$

$$\therefore \text{Error} = -0.03 - (0.03) = -0.06 \text{ m}$$

4. Tacheometric, Curve, Hydrographic and Plane Table Surveying & Theory of Errors**4.1 Sol.**

The resected position of plane table station from three known position is unreliable, if the station lies on the great circle passing through the three known position.

4.2 (b)

- In the two theodolite method, 2 theodolite are used for angular measurements and no linear

measurements are taken.

- One theodolite is set at the point of curvature and the other at the point of tangency.

4.3 (a)

A systematic error is an error that under the same condition will always be of same size and sign. They follows some definite mathematical or physical law, and a correction can be determined and applied. They are of constant character and are regarded as positive or negative.

Their effect is cumulative.

4.4 (a)

1. Tilt of staff away from the telescope pointing up the hill.

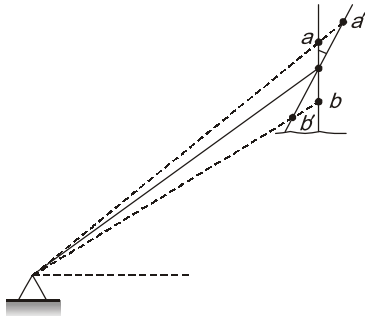

2. Tilt of staff towards the telescope pointing up the hill.

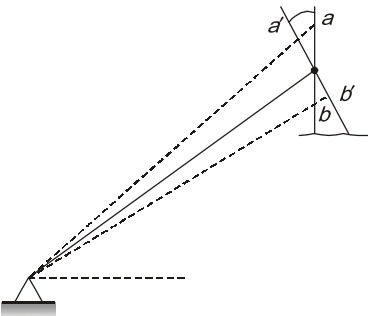

3. Tilt of staff away from the telescope pointing down the hill.

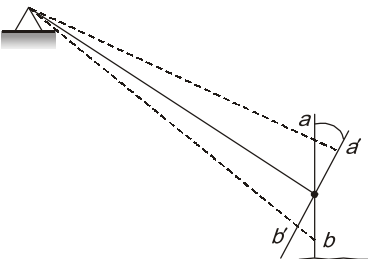

Hence, the intercept $a'b'$ formed is greater than ab when the staff is tilted away from the telescope pointing up the hill.

4.5 Sol.

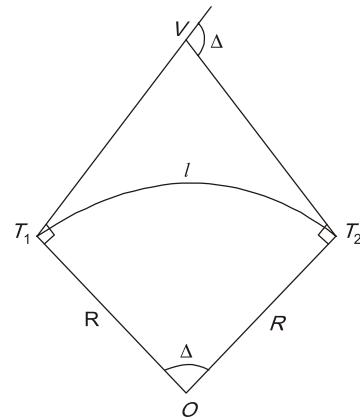

Here, $\Delta = 30^\circ; l = 150 \text{ m}$

Now, $l = 2\pi r \times \left(\frac{D}{360^\circ}\right)$

$\Rightarrow 150 = 2\pi r \times \left(\frac{30}{360}\right)$

$\Rightarrow R = 286.48 \text{ m}$

Tangenth length = $T_1V = T_2V = R \tan\left(\frac{\Delta}{2}\right)$
 $= 286.48 \tan 15^\circ = 76.76 \text{ m}$

4.6 (b)

An additional convex lens is provided between the eyepiece and the object glass at a fixed distance from the object glass. These lens are called anallatic lens.

The purpose of providing anallatic lens is to make additive constant equals to zero.

4.7 (a)

In case of **tangential method**, the stadia hairs are not used, the readings being taken against the horizontal cross-hair. To measure the staff intercept, two pointings of the instruments are, therefore, necessary. This necessitates measurement of vertical angles twice for one single observation.

Hence, it is a slower method.

4.8 (b)

To find the normal equation of P,

$1 \times P = 30^\circ 28' 40'' \quad \dots(i)$

$3 \times 3P = 274^\circ 17' 45'' \quad \dots(ii)$

$4 \times 4P = 487^\circ 38' 0'' \quad \dots(iii)$

On adding eq. (i), (ii) and (iii)

$26 P = 792^\circ 24' 25''$

$\Rightarrow P = 30^\circ 28' 37.88''$



Engineering Mathematics

UNIT

XII

CONTENTS

1. Linear Algebra 69
2. Calculus 69
3. Differential Equations 69
4. Laplace Transforms 70

Engineering Mathematics

1. Linear Algebra

1.1 The rank of the matrix $A = \begin{bmatrix} 1 & -2 & -1 \\ -3 & 3 & 0 \\ 2 & 2 & 4 \end{bmatrix}$ is

- (a) One (b) Two
(c) Three (d) None of these

[1994 : 1 Mark]

1.2 The Eigen vectors of the matrix $\begin{bmatrix} 1 & -1 \\ -1 & 1 \end{bmatrix}$ is/are

- (a) (1, 0) (b) (0, 1)
(c) (1, 1) (d) (1, -1)

[1994 : 1 Mark]

1.3 The inverse of the matrix $A = \begin{bmatrix} -3 & 5 \\ 2 & 1 \end{bmatrix}$ is

- (a) $\begin{bmatrix} 5 & -1 \\ 13 & 13 \\ 2 & 3 \\ 13 & 13 \end{bmatrix}$ (b) $\begin{bmatrix} 2 & 5 \\ 13 & 13 \\ -1 & 3 \\ 13 & 13 \end{bmatrix}$
(c) $\begin{bmatrix} -1 & 5 \\ 13 & 13 \\ 2 & 3 \\ 13 & 13 \end{bmatrix}$ (d) $\begin{bmatrix} 1 & -5 \\ 13 & 13 \\ 2 & 3 \\ 13 & 13 \end{bmatrix}$

[1994 : 2 Marks]

2. Calculus

2.1 The limit of $\lim_{\theta \rightarrow 0} \frac{\sin \theta}{\theta}$ is

- (a) 1 (b) 0
(c) ∞ (d) None of these

[1994 : 1 Mark]

2.2 The function, $y = x^2 + \frac{250}{x}$, at $x = 5$

- (a) Maximum (b) Minimum
(c) Neither (d) 1

[1994 : 1 Mark]

2.3 The volume generated by revolving the area bounded by the parabola $y^2 = 8x$ and the line $x = 2$ about y-axis is

- (a) $\frac{128\pi}{5}$ (b) $\frac{5}{128\pi}$
(c) $\frac{127}{5\pi}$ (d) None of these

[1994 : 1 Mark]

2.4 The directional derivative of $f(x, y) = 2x^2 + 3y^2 + z^2$ at point P(2, 1, 3) in the direction of the vector $\vec{a} = \vec{i} - 2\vec{k}$ is

- (a) $\frac{4}{\sqrt{5}}$ (b) $-\frac{4}{\sqrt{5}}$
(c) $\frac{\sqrt{5}}{4}$ (d) $-\frac{\sqrt{5}}{4}$

[1994 : 1 Mark]

2.5 The integration of $\int \log x dx$ has the value

- (a) $(x \log x - 1)$ (b) $\log x - x$
(c) $x(\log x - 1)$ (d) None of these

[1994 : 1 Mark]

3. Differential Equations

3.1 The necessary and sufficient condition for the differential equation of the form $M(x, y) dx + N(x, y) dy = 0$ to be exact is

- (a) $M = N$ (b) $\frac{\partial M}{\partial x} = \frac{\partial N}{\partial y}$
(c) $\frac{\partial M}{\partial y} = \frac{\partial N}{\partial x}$ (d) $\frac{\partial^2 M}{\partial x^2} = \frac{\partial^2 N}{\partial y^2}$

[1994 : 1 Mark]

3.2 The differential equation

$$EI \frac{d^4 y}{dx^4} + P \frac{d^2 y}{dx^2} + ky = 0$$

- (a) Linear of Fourth order
(b) Non-linear of Fourth order
(c) Non-Homogeneous
(d) Linear and Fourth degree

[1994 : 1 Mark]

4. Laplace Transforms

4.1 The Laplace transform of the function $(t) = e^{at}$ when $t > 0$ and where a is a constant is

- (a) $\frac{1}{(s-a)}$ (b) $\frac{1}{(s+a)}$
 (c) $\frac{1}{(s-a)^{-1}}$ (d) $\frac{1}{(s+a)^{-1}}$

[1994 : 1 Mark]

Answers Engineering Mathematics

1.1 (b) 1.2 (c, d) 1.3 (c) 2.1 (a) 2.2 (b) 2.3 (d) 2.4 (b) 2.5 (c) 3.1 (c)
 3.2 (a) 4.1 (a)

Explanations Engineering Mathematics

1. Linear Algebra

1.1 (b)

$$\begin{aligned} \because |A| &= 0 \\ \Rightarrow \rho(A) &< 3 \end{aligned}$$

And as 2×2 minor of 3×3 matrix is not equal to zero. Hence rank of matrix $[A]$ is two.

1.2 (c, d)

$$\begin{aligned} &\begin{vmatrix} 1-\lambda & -1 \\ -1 & 1-\lambda \end{vmatrix} \\ \Rightarrow &\lambda = 0, 2 \end{aligned}$$

Now, for $\lambda = 0$

$$\begin{bmatrix} 1 & -1 \\ -1 & 1 \end{bmatrix} \begin{bmatrix} x_1 \\ x_2 \end{bmatrix} = \begin{bmatrix} 0 \\ 0 \end{bmatrix}$$

$$\Rightarrow x_1 - x_2 = 0$$

$$\Rightarrow -x_1 + x_2 = 0$$

$$\Rightarrow \begin{bmatrix} x_1 \\ x_1 \end{bmatrix} = \begin{bmatrix} 1 \\ 1 \end{bmatrix}$$

\therefore Eigen vector is $[1, 1]$

For $\lambda = 2$

$$\begin{bmatrix} -1 & -1 \\ -1 & -1 \end{bmatrix} \begin{bmatrix} x_1 \\ x_2 \end{bmatrix} = \begin{bmatrix} 0 \\ 0 \end{bmatrix}$$

$$-x_1 - x_2 = 0$$

$$-x_1 = x_2$$

\therefore Eigen vector $[-1, 1]$ or $[1, -1]$

1.3 (c)

$$A = \begin{bmatrix} -3 & 5 \\ 2 & 1 \end{bmatrix}$$

$$\text{We know that } A^{-1} = \frac{\text{adj}[A]}{|A|}$$

Co-factors of the matrix $[A]$ is,

$$\begin{aligned} C_{11} &= 1 & C_{12} &= -2 \\ C_{22} &= -5 & C_{21} &= -3 \end{aligned}$$

Matrix formed by the co-factor of $[A]$ is,

$$\begin{bmatrix} 1 & -2 \\ -5 & -3 \end{bmatrix} \therefore \text{adj}[A] = \begin{bmatrix} 1 & -5 \\ -2 & -3 \end{bmatrix}$$

$$\begin{aligned} \therefore \text{adj}[A] &= |A| = (-3 \times 1) - (2 \times 5) \\ &= -3 - 10 = -13 \end{aligned}$$

$$\therefore A^{-1} = \begin{bmatrix} -1/13 & 5/13 \\ 2/13 & 3/13 \end{bmatrix}$$

2. Calculus

2.1 (a)

$$\text{We know that } \lim_{\theta \rightarrow 0} \frac{\sin \theta}{\theta} = 1$$

$$\lim_{\theta \rightarrow 0} \frac{\tan \theta}{\theta} = 1$$

2.2 (b)

$$y = x^2 + \frac{250}{x}$$

$$\Rightarrow \frac{dy}{dx} = 2x + 250\left(\frac{-1}{x^2}\right)$$

if $\frac{dy}{dx} = 0$

they $2x = \frac{250}{x^2}$

$$\Rightarrow x^3 = 125$$

$$\therefore x = 5$$

Now, $\frac{d^2y}{dx^2} = 2x + 250 \times \frac{2}{x^3}$

of $x = 5$

$$\frac{d^2y}{dx^2} = 2 \times 5 + \frac{500}{(5)^3}$$

$$= 14 > 0$$

\therefore the function $y = x^2 + \frac{250}{x}$ attain minimum value at $x = 5$.

2.3 (d)

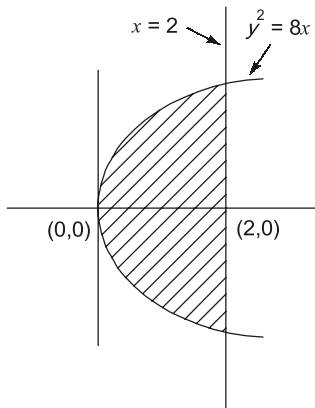

The volume generated by revolving the area bounded by the parabola $y^2 = 8x$ and line $x = 2$ about y -axis is

$$\int_{x=0}^{x=2} \sqrt{8x} \, dx = 2\sqrt{2} \left[\frac{x^{3/2}}{3/2} \right]_0^2$$

$$= 2\sqrt{2} \times \frac{2}{3} [2]^{3/2} = 5.33$$

2.4 (b)

$$\nabla f = 4x\hat{i} + 6y\hat{j} + 2z\hat{k}$$

$$\nabla f|_{P(2,1,3)} = 8\hat{i} + 6\hat{j} + 6\hat{k}$$

Directional derivative in the direction of vector \vec{a}

$$= (8\hat{i} + 6\hat{j} + 6\hat{k}) \frac{(\hat{i} - 2\hat{k})}{\sqrt{5}}$$

$$= \frac{(8 - 12)}{\sqrt{5}} = -\frac{4}{\sqrt{5}}$$

2.5 (c)

$$\int \log x \cdot dx$$

$$= \int \log x \cdot 1 \, dx$$

$$= \log x \int 1 \cdot dx - \int \left[\left(\frac{d \log x}{dx} \right) \int 1 \cdot dx \right] dx$$

$$= \log x \cdot x - \int \frac{1}{x} \cdot x \cdot dx$$

$$= x \log x - x + c$$

3. Differential Equations

4.1 (c)

The differential equation, $Mdx + Ndy = 0$ is said to be exact when

$$\frac{\partial M}{\partial y} = \frac{\partial N}{\partial x}$$

4.2 (a)

The differential equation

$$E.I. \frac{d^4 y}{dx^4} + P. \frac{d^2 y}{dx^2} + k.y = 0$$
 has

order 'Four' but degree 'one'
 As all derivative consist one degree so we can say the differential equation is linear.

