

GATE

Mechanical Engineering

(Previous Years Solved Papers 1987-1994)

Contents

1. Engineering Mechanics	1 - 4
2. Strength of Materials	5 - 16
3. Theory of Machines	17 - 20
4. Machine Design	21 - 28
5. Fluid Mechanics and Hydraulic Machines	29 - 42
6. Heat Transfer	43 - 52
7. Thermodynamics	53 - 60
8. Power Plant Engineering	61 - 68
9. IC Engines	69 - 73
10. Refrigeration & Air-Conditioning	74 - 78
11. Manufacturing Engineering	79 - 94
12. Industrial Engineering	95 - 97



Engineering Mechanics

UNIT

I

CONTENTS

- | | | |
|----|--------------------------|---|
| 1. | Translation and Rotation | 2 |
| 2. | Plane Motion | 3 |

1

Translation and Rotation

- 1.1 A stone of mass m at the end of a string of length l is whirled in a vertical circle at a constant speed. The tension in the string will be maximum when the stone is
- (a) at the top of the circle
 - (b) half way down from the top
 - (c) quarter way down from the top
 - (d) at the the bottom of the circle

[1994 : 1 Mark]



Answers Translation and Rotation

1.1 (d)

Explanations Translation and Rotation

1.1 (d)

Considering dynamic equilibrium

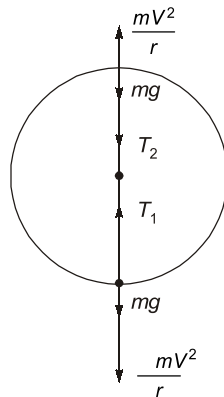

$$T_1 = mg + \frac{mV^2}{r}$$

$$T_2 = \frac{mV^2}{r} - mg$$

Therefore, $T_1 > T_2$

Maximum tension will be at the bottom of the circle.



2.1 A and B are the end points of a diameter of a disc rolling along a straight line with a counter clockwise angular velocity as shown in the figure. Referring to the velocity vectors \vec{V}_A and \vec{V}_B shown in the figure

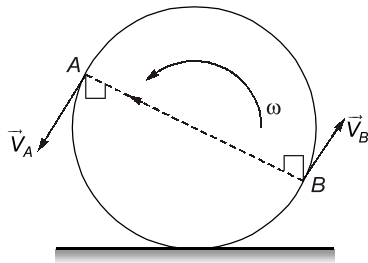

- (a) \vec{V}_A and \vec{V}_B are both correct
- (b) \vec{V}_A is incorrect but \vec{V}_B is correct
- (c) \vec{V}_A and \vec{V}_B are both incorrect
- (d) \vec{V}_A is correct but \vec{V}_B is incorrect

[1990 : 1 Mark]

2.2 Instantaneous centre of a body rolling without sliding on a stationary curved surface lies.

- (a) at the point of contact
- (b) on the common normal at the point of contact

- (c) on the common tangent at the point of contact
- (d) at the centre of curvature of the stationary surface

[1992 : 1 Mark]

2.3 The cylinder shown below rolls without slipping. Toward which of the following points is the acceleration of the point of contact A on the cylinder directed?

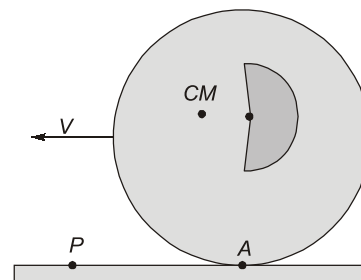

- (a) The mass centre
- (b) The geometric centre
- (c) The point P as marked
- (d) None of the above

[1993 : 1 Mark]



Answers Plane Motion

2.1 (c) 2.2 (a) 2.3 (b)

Explanations Plane Motion

2.1 (c)

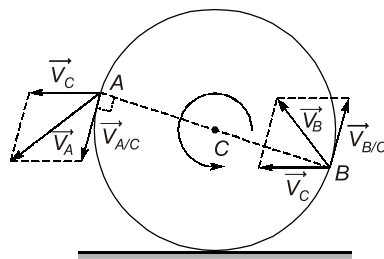

$$\vec{V}_A = \vec{V}_C + \vec{V}_{A/C}$$

$$\vec{V}_B = \vec{V}_C + \vec{V}_{B/C}$$

2.2 (a)

Because for rolling without sliding, contact point has zero velocity.



POINTS TO REMEMBER

Instantaneous centre of rotation: In general, the motion of a link in a mechanism is neither pure translational nor pure rotational. It is the combination of translational and rotational which we say general motion. But for a link at any instant, it can be assumed to be in perfect rotation with respect to a point in the space known as instantaneous centre of rotation.

2.3 (b)

Acceleration of the point of contact A acts towards geometric centre.

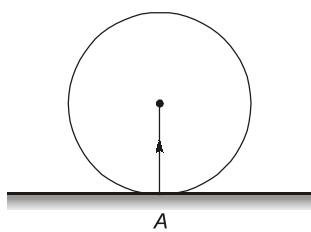

$$\vec{a}_A = r\omega^2(\hat{j})$$



Strength of Materials

UNIT

II

CONTENTS

1.	Simple Stress-Strain and Elastic Constants	6
2.	Shear Force and Bending Moment	8
3.	Bending and Shear Stress in Beams	9
4.	Torsion in Shafts	12
5.	Principal Stresses and Strains	13
6.	Theory of Column	15
7.	Springs	16

1.1 The three-dimensional state of stress at a point is given by

$$[\sigma] = \begin{bmatrix} 30 & 10 & -10 \\ 10 & 0 & 20 \\ -10 & 20 & 0 \end{bmatrix} \text{ MN/m}^2$$

The shear stress on the x -face in y -direction at the same point is then equal to

- (a) zero MN/m^2 (b) -10 MN/m^2
 (c) 10 MN/m^2 (d) 20 MN/m^2

[1990 : 2 Marks]

1.2 Below figure shows a rigid bar hinged at A and supported in a horizontal position by two vertical identical steel wires. Neglect the weight of the beam. The tension T_1 and T_2 induced in these wires by a vertical load P applied as shown are

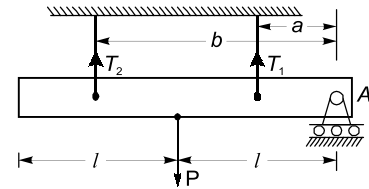

- (a) $T_1 = T_2 = \frac{P}{2}$
 (b) $T_1 = \frac{Pal}{(a^2 + b^2)}$, $T_2 = \frac{Pbl}{(a^2 + b^2)}$
 (c) $T_1 = \frac{Pbl}{(a^2 + b^2)}$, $T_2 = \frac{Pal}{(a^2 + b^2)}$
 (d) $T_1 = \frac{Pal}{2(a^2 + b^2)}$, $T_2 = \frac{Pbl}{2(a^2 + b^2)}$

[1994 : 2 Marks]



Answers Simple Stress-Strain and Elastic Constants

1.1 (c) 1.2 (b)

Explanations Simple Stress-Strain and Elastic Constants

1.1 (c)

$$\sigma = \begin{bmatrix} 30 & 10 & -10 \\ 10 & 0 & 20 \\ -10 & 20 & 0 \end{bmatrix}$$

$$\sigma = \begin{bmatrix} \sigma_x & \tau_{xy} & \tau_{xz} \\ \tau_{yx} & \sigma_y & \tau_{yz} \\ \tau_{zx} & \tau_{zy} & \sigma_z \end{bmatrix}$$

Shear stress on the x -face in y -direction is represented by τ_{xy} . Hence on comparing above two matrices

$$\tau_{xy} = 10 \text{ MN/m}^2$$

1.2 (b)

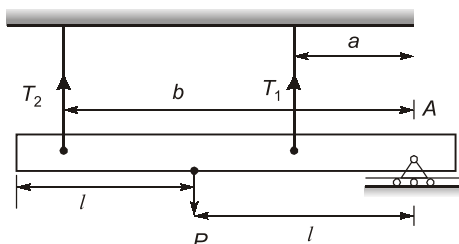

The free body diagram is

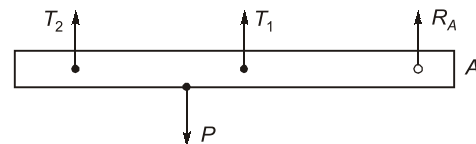

R_A is the reaction force at A.

Let the rigid bar attain equilibrium at an angle θ from horizontal position.

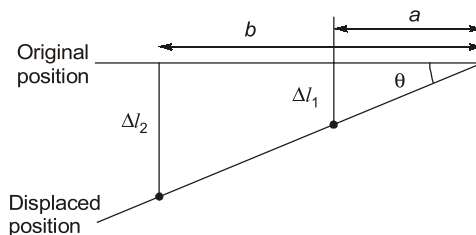

Δl_2 = change in length of steel wire carrying tension T_2 .

Δl_1 = change in length of steel wire carrying tension T_1 .

$$\Delta l = \frac{PL}{AE}$$

$$\therefore \Delta l_2 = \frac{T_2 L}{AE}, \quad \Delta l_1 = \frac{T_1 L}{AE}$$

$$\therefore \tan \theta = \frac{\Delta l_2}{b} = \frac{\Delta l_1}{a} \quad \text{or} \quad \Delta l_2 = \frac{b}{a} \Delta l_1$$

$$\text{or} \quad \frac{T_2 L}{AE} = \frac{b}{a} \times \frac{T_1 L}{AE} \quad \text{or} \quad T_2 = \frac{b}{a} T_1$$

At equilibrium summation of all moments about point A will be zero.

$$\therefore \Sigma M_A = T_2 b + T_1 a - Pl = 0$$

$$\therefore T_2 b + T_1 a = Pl$$

$$\left(\frac{b}{a} T_1\right) b + T_1 a = Pl$$

$$\frac{T_1 b^2}{a} + T_1 a = Pl$$

$$T_1 b^2 + T_1 a^2 = Pal$$

$$T_1 = \frac{Pal}{a^2 + b^2}$$

$$\text{Therefore} \quad T_2 = \frac{b}{a} \times T_1$$

$$T_2 = \frac{b}{a} \times \frac{Pal}{a^2 + b^2} = \frac{Pbl}{a^2 + b^2}$$



2.1 For a simply supported beam on two end supports, the bending moment is maximum

- (a) usually on the supports
- (b) always at mid span
- (c) where there is no shear force
- (d) where the deflection is maximum

[1989 : 1 Mark]

2.2 A block of steel is loaded by a tangential force on its top surface while the bottom surface is held rigidly. The deformation of the block is due to

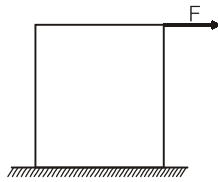

- (a) shear only
- (b) bending only
- (c) shear & bending
- (d) torsion

[1992 : 1 Mark]

2.3 A concentrated load P acts on a simply supported beam of span L at a distance $L/3$ from the left support. The bending moment at the point of application of the load is given by

- (a) $\frac{PL}{3}$
- (b) $\frac{2PL}{3}$
- (c) $\frac{PL}{9}$
- (d) $\frac{2PL}{9}$

[1993 : 1 Mark]



Answers Shear Force and Bending Moment

2.1 (c) 2.2 (c) 2.3 (d)

Explanations Shear Force and Bending Moment

2.1 (c)

Bending moment is maximum where shear force is zero.

2.2 (c)

If tangential force is applied, then both shear and bending takes place. For long blocks we generally neglect the effect of shear. For short blocks we generally neglect the effect of bending.

2.3 (d)

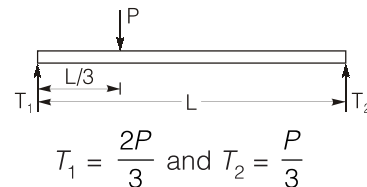

At point of application

$$BM = \frac{2P}{3} \times \frac{L}{3} = \frac{2PL}{9}$$



3

Bending and Shear Stress in Beams

- 3.1 A 6 meter long supported wooden beam of rectangular section 10 cm × 20 cm deep is strengthened by mild steel plates 0.5 cm × 10 cm wide at the top and bottom fibre over the entire length. Find the minimum supportable uniformly distributed load considering failures in steel and wood due to flexure. Weakening of wood due to screws and weakening of the steel plates due to drilled holes may be ignored

Permissible tensile stress for steel
= 156.8 N/mm²

Permissible tensile stress for wood
= 14.89 N/mm²

Young's modulus of mild steel
= 1.96 × 10⁵ N/mm²

Young's modulus of wood
= 0.117 × 10⁵ N/mm²

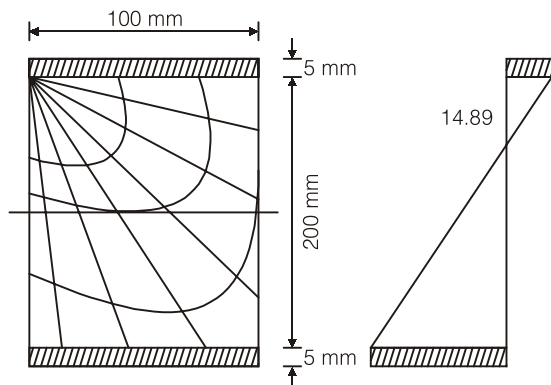

[1987 : 2 Marks]

- 3.2 A tapered cantilever beam of constant thickness is loaded as shown in the sketch below. The bending stress will be

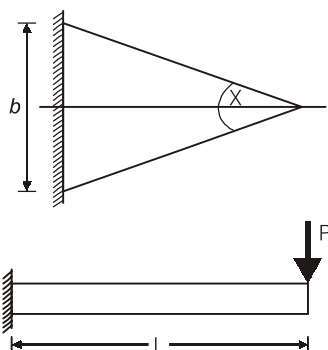

- (a) maximum near the fixed end
(b) maximum at $x = \frac{1}{2}L$
(c) maximum at $x = \frac{2}{3}L$
(d) uniform throughout the length

[1988 : 2 Marks]

- 3.3 Which one of the following diagrams shows correctly the distribution of transverse shear stress across the depth h of a rectangular beam subjected to varying bending moment along its length?

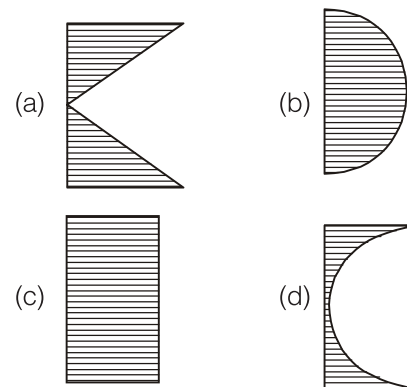

[1990 : 1 Mark]

- 3.4 A circular rod of diameter d and length $3d$ is subjected to a compressive force F acting at the top point as shown below. Calculate the stress at the bottom most supports point A

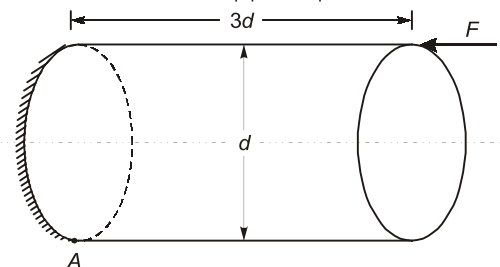

- (a) $\frac{12F}{\pi d^2}$
(b) $\frac{16F}{\pi d^2}$
(c) $-\frac{4F}{\pi d^2}$
(d) $-\frac{12F}{\pi d^2}$

[1993 : 2 Marks]



Answers Bending and Shear Stress in Beams

3.1 (4.81) 3.2 (d) 3.3 (b) 3.4 (a)

Explanations Bending and Shear Stress in Beams**3.1 Sol.**

Modular ratio,

$$m = \frac{E_s}{E_t} = \frac{1.96 \times 10^5}{0.117 \times 10^5} = 16.75$$

Equivalent steel area of timber beam

$$\text{Equivalent width} = \frac{100}{16.75} = 5.97 \text{ mm}$$

Hence equivalent beam will be

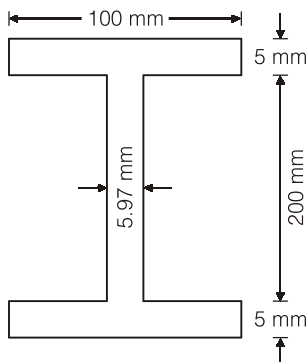

$$I_{eq} = \frac{100 \times 210^3}{12} - \frac{94.03 \times 200^3}{12}$$

$$= 14.5 \times 10^6 \text{ mm}^4$$

Now if permissible stress in steel

$$= 156.8 \text{ MPa}$$

Stress in timber will be

$$= \frac{156.8}{105} \times 100 \times \frac{1}{16.75} = 8.915 \text{ MPa}$$

Which is less than maximum permissible stress

If permissible stress is wood

$$= 14.8 \text{ MPa}$$

Stress in steel

$$= \frac{14.89}{100} \times 105 \times 16.75$$

$$= 261.88 \text{ N/mm}^2$$

Which is greater than maximum permissible stress hence maximum stress in steel should be limited to 156.8 MPa.

From bending equation

$$\frac{M}{I} = \frac{\sigma}{y}$$

$$M = \frac{156.8 \times 14.5 \times 10^6}{105} = 21.65 \text{ MNm}$$

$$\frac{wl^2}{8} = M = 21.65 \times 10^6$$

$$w = \frac{8 \times 21.65 \times 10^6}{(6000)^2} = 4.81 \text{ N/mm}$$

$$= 4.81 \text{ kN/m}$$

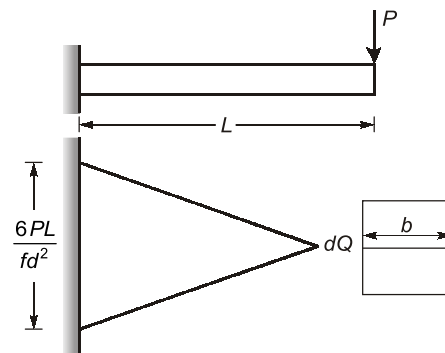
3.2 (d)

$$\frac{M}{I} = \frac{\sigma}{d/2}$$

$$\Rightarrow \frac{PL}{bd^3/12} = \frac{\sigma}{d/2}$$

$$\text{and } \sigma = f$$

$$f = \sigma = \frac{6PL}{bd^2}$$

$$b = \frac{6PL}{fd^2}$$

As σ (bending stress) is independent of x , the beam is of uniform strength.

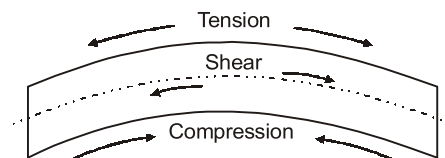
3.3 (b)

Transverse shear stress is minimum at top and bottom edges and its value is maximum at neutral axis.

3.4 (a)

In the question
The given load is equal to a moment and a force at G to the stress

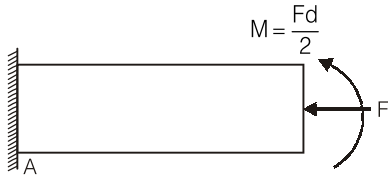

Bending stress,

$$\sigma_b = \frac{M}{Z}$$

where $M = F \times d/2$

$$Z = \frac{I}{y}$$

where, $I = \frac{\pi}{64}d^4$, $y = \frac{d}{2}$

$$\therefore Z = \frac{I}{y} = \frac{\pi d^4 \times 2}{64 d} = \frac{\pi d^3}{32}$$

$$\begin{aligned} \therefore \sigma_b &= \frac{M}{Z} = \frac{F \times \frac{d}{2}}{\frac{\pi d^3}{32}} \\ &= \frac{16F}{\pi d^2} \end{aligned} \quad \text{(Tensile)}$$

Axial stress,

$$\sigma_a = \frac{\text{Force}}{\text{Area}} = \frac{F}{\frac{\pi}{4}d^2}$$

$$= \frac{4F}{\pi d^2} \quad \text{(Compressive)}$$

Combined stress = $\sigma_a + \sigma_b$

$$= -\frac{4F}{\pi d^2} + \frac{16F}{\pi d^2} = \frac{12F}{\pi d^2}$$



- 4.1 The compound shaft shown is built-in at the two ends. It is subjected to a twisting moment T at the middle. What is the ratio of the reaction torques T_1 and T_2 at the ends?

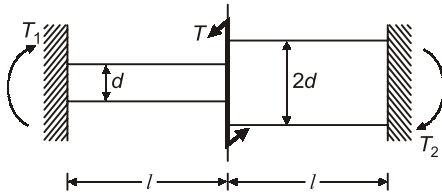

- (a) $\frac{1}{16}$ (b) $\frac{1}{8}$

- (c) $\frac{1}{4}$ (d) $\frac{1}{2}$

[1993 : 2 Marks]

- 4.2 Two shafts A and B are made of the same material. The diameter of shaft B is twice that of shaft A . The ratio of power which can be transmitted by shaft A to that of shaft B is (If maximum shear stress remains the same)

- (a) $\frac{1}{2}$ (b) $\frac{1}{4}$
 (c) $\frac{1}{8}$ (d) $\frac{1}{16}$

[1994 : 2 Marks]



Answers Torsion in Shafts

- 4.1 (a) 4.2 (c)

Explanations Torsion in Shafts

4.1 (a)

At the joints, $\theta_1 = \theta_2$

$$\Rightarrow \frac{T_1 L_1}{G J_1} = \frac{T_2 L_2}{G J_2} \quad \left[J = \frac{\pi}{32} d^4 \right]$$

$$\frac{T_1 L}{G \frac{\pi d^4}{32}} = \frac{T_2 L}{G \frac{\pi (2d)^4}{32}}$$

or $\frac{T_1}{T_2} = \frac{1}{16}$

4.2 (c)

$$P = T\omega$$

Putting torsion formula

$$\frac{T}{J} = \frac{\tau}{d/2}$$

$$\Rightarrow T = \frac{\tau \times \frac{\pi d^4}{32}}{d/2} = \frac{\tau \pi d^3}{16}$$

Since material of both shafts are same, τ will be same

$$P \propto d^3$$

Now, if $d_B = 2d_A$

$$\frac{P_A}{P_B} = \frac{1}{8}$$



- 5.1 A cylindrical elastic body subjected to pure torsion about its axis develops
- tensile stress in a direction 45° to the axis
 - no tensile or compressive stress
 - maximum shear stress along the axis of the shaft
 - maximum shear stress at 45° to the axis

[1989 : 1 Mark]

- 5.2 An elastic body is subjected to a tensile stress X in a particular direction and a compressive stress Y in its perpendicular direction. X and Y are unequal in magnitude. On the plane of maximum shear stress in the body there will be
- no normal stress
 - also the maximum normal stress

- the minimum normal stress
- both normal stress and shear stress

[1989 : 1 Mark]

- 5.3 At a point in a stressed body the state of stress on two planes 45° apart is as shown below. Determine the two principal stresses in MPa.

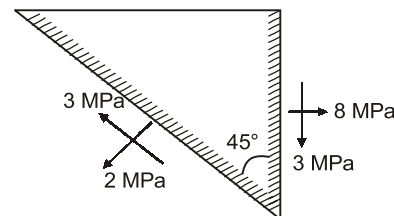

- 8.242, 0.658
- 9.242, 0.758
- 9.242, 0.758
- 8.242, 0.758

[1993 : 2 Marks]



Answers Principal Stresses and Strains

- 5.1 (a) 5.2 (d) 5.3 (b)

Explanations Principal Stresses and Strains

5.1 (a)

State of stress for pure torsion can be shown as:

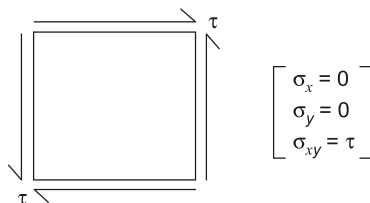

Principal stresses can be found out as

$$\begin{aligned}\sigma_{1,2} &= \frac{\sigma_x + \sigma_y}{2} \pm \sqrt{\left(\frac{\sigma_x - \sigma_y}{2}\right)^2 + \tau_{xy}^2} \\ &= 0 \pm \sqrt{(0)^2 + \tau^2} = \pm \tau\end{aligned}$$

Angle for principal planes,

$$\tan 2\theta = \frac{2\tau_{xy}}{\sigma_x - \sigma_y} = \frac{2\tau}{0} = \infty$$

$$2\theta = 90^\circ \text{ or } \theta = 45^\circ \text{ or } 135^\circ$$

So, at $\theta = 45^\circ$

$$\sigma_\theta = \frac{1}{2}(\sigma_x + \sigma_y) + \frac{1}{2}(\sigma_x - \sigma_y) \cos 2\theta + \tau \cdot \sin 2\theta$$

$$\sigma_{\theta=45^\circ} = \tau \sin 90^\circ = \tau$$

$$\sigma_{\theta=135^\circ} = -\tau$$

Hence, at $\theta = 45^\circ$, we have maximum principal stress which is tensile in nature and magnitude of τ . So, the correct option is (a).

Method II:

We can solve the same problem by using Mohr's circle method.

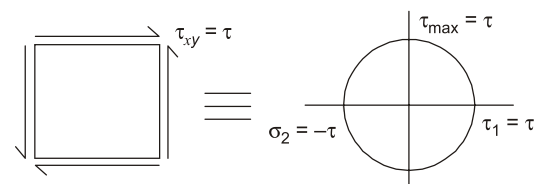

5.2 (d)

If

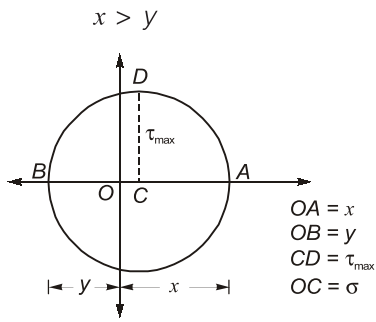

5.3 (b)

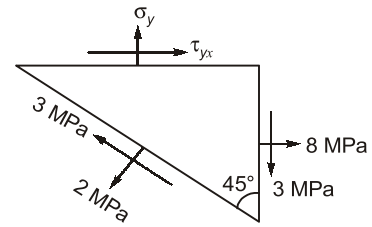

$$2 = \left(\frac{8 + \sigma_y}{2} \right) + \left(\frac{8 - \sigma_y}{2} \right) \cos 90^\circ - 3 \sin 90^\circ$$

$$\Rightarrow \sigma_y = 2 \text{ MPa}$$

$$\begin{aligned} \sigma_{1,2} &= \frac{8+2}{2} \pm \sqrt{\left(\frac{8-2}{2} \right)^2 + 3^2} \\ &= 5 \pm 4.242 \\ &= 9.242, +0.758 \text{ MPa} \end{aligned}$$



6.1 If the length of a column is doubled, the critical load becomes

- (a) 1/2 of the original value
- (b) 1/4 of the original value
- (c) 1/8 of the original value
- (d) 1/16 of the original value

[1988 : 1 Mark]

6.2 For the case of a slender column of length l , and flexural rigidity EI built in at its base and free at the top, the Euler's critical buckling load is

- (a) $\frac{4\pi^2 EI}{l^2}$
- (b) $\frac{2\pi^2 EI}{l^2}$
- (c) $\frac{\pi^2 EI}{l^2}$
- (d) $\frac{\pi^2 EI}{4l^2}$

[1994 : 1 Mark]



Answers Theory of Column

6.1 (b) 6.2 (d)

Explanations Theory of Column

6.1 (b)

$$P = \frac{\pi^2 EI}{l^2} \Rightarrow P \propto \frac{1}{l^2}$$

If $l' = 2l$

$$P' = \frac{1}{4} \times P$$

6.2 (d)

In this case, effective length = $2l$

$$P = \frac{\pi^2 EI}{(2l)^2} = \frac{\pi^2 EI}{4l^2}$$



7.1 The figure shows arrangements of springs. They have stiffness k_1 and k_2 as marked. Which of the following arrangements offers a stiffness = $\frac{2k_1k_2}{k_1 + 2k_2}$?

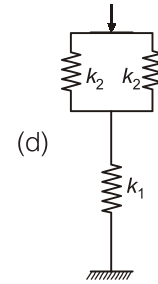
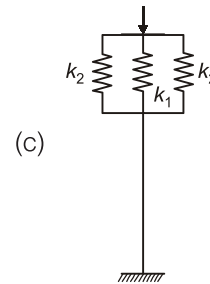
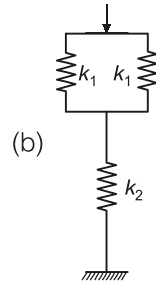
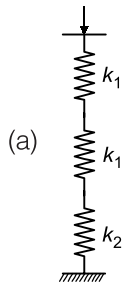

[1987 : 1 Mark]



Answers Springs

7.1 (d)

Explanations Springs

7.1 (d)

$$\frac{1}{k} = \frac{1}{k_1} + \frac{1}{2k_2}$$

$$k = \frac{2k_1k_2}{k_1 + 2k_2} \quad (\text{series arrangement})$$



Theory of Machines

UNIT III

CONTENTS

1. Planar Mechanisms 18
2. Gear and Gear Train 19

- 1.1 Instantaneous centre of a body rolling with sliding on a stationary curved surface lies
- at the point of contact
 - on the common normal at the point of contact
 - on the common tangent at the point of contact
 - at the center of curvature of the stationary surface

[1992 : 2 Marks]

- 1.2 The number of degrees of freedom of a five link plane mechanism with five revolute pairs as shown in the figure is

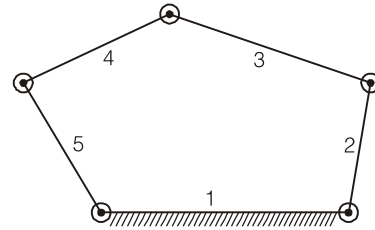

- 3
- 4
- 2
- 1

[1993 : 2 Marks]

Answers Planar Mechanisms

- 1.1 (b) 1.2 (c)

Explanations Planar Mechanisms

1.1 (b)

This is a case of rolling with sliding on a stationary curved surface, so instantaneous centre of the body will lie on the common normal at the point of contact, it means line joining two extreme cases.



POINTS TO REMEMBER

- Instantaneous centre of a body rolling without sliding on a stationary curved surface will lie at the point of contact surface.
- Instantaneous centre of a body in case of pure sliding on a stationary curved surface at the point where it is centred at curved surface.

1.2 (c)

$$DOF = 3(N - 1) - 2j - h.$$

Here, $N = 5$, $j = 5$. (no. of pairs having one degree of freedom)

$$\begin{aligned} DOF &= 3(5 - 1) - 2 \times 5 \\ &= 12 - 10 = 2 \end{aligned}$$

- 2.1 For full depth of involute spur gears, minimum number of teeth of pinion to avoid interference depends upon
 (a) pressure angle (b) speed ratio
 (c) circular pitch (d) pitch diameter

[1988 : 1 Mark]

- 2.2 Modern gear tooth profile is given involute shape because
 (a) this is a very easy curve for manufacturing
 (b) sliding does not takes place anywhere on meshing teeth
 (c) involute is the only profile that gives conjugate action
 (d) change in the centre distance does not change gear ratio

[1989 : 1 Mark]

- 2.3 For a pinion of 15 teeth, under cutting (increases/decreases) with (increase/decrease) of pressure angle.

[1991 : 1 Mark]

- 2.4 The sun gear in the figure is driven clockwise at 100 rpm. The ring gear is held stationary. For the number of teeth shown on the gears, the arm rotates at

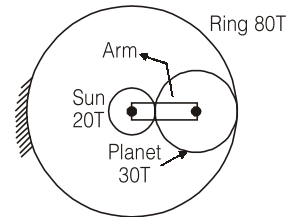

- (a) 0 rpm (b) 20 rpm
 (c) 33.33 rpm (d) 666.67 rpm

[1993 : 2 Marks]

- 2.5 In spur gears having involute teeth, the product of circular pitch and diametral pitch is.....

[1994 : 1 Mark]



Answers Gear and Gear Train

- 2.1 (a) 2.2 (d) 2.3 (decreases, increases) 2.4 (b) 2.5 (π)

Explanations Gear and Gear Train

2.3 Sol.

Interference decreases with increase in pressure angle.

2.4 (b)

Method I:

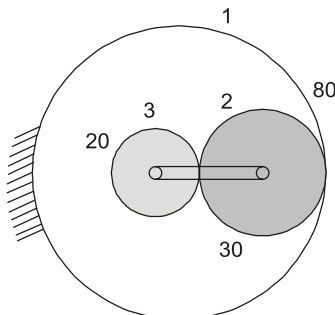

Gear	1	2	3
No. of teeth	80	30	20 (sun)
Speed of (RPM)	+ N positive sign means clockwise	$\frac{+ N \times 80}{30}$ clockwise for internal gear meshing	$\frac{- N \times 80 \times 30}{30 \times 20}$ anti-clockwise for external gear meshing
Speed after adding speed of arm + y (clockwise)	$N + y$	$\frac{+ N \times 80}{30} + y$	$\frac{- N \times 80 \times 30}{30 \times 20} + y$

Given :

$$N + y = 0$$

$$y = -N$$

Sun gear means "3"

$$\frac{-N \times 80 \times 30}{30 \times 20} + y = 0$$

$$-4N - N = 100$$

...(1)

$$-5N = 100$$

$$N = -20$$

$$\therefore y = -N = + 20 \text{ rpm}$$

Method II:

Relative velocity method:

$$\text{Given: } T_s = 20, T_p = 30, T_R = 80$$

$$N_S = 100 \text{ rpm (CW), } N_R = 0, N_a = ?$$

$$\frac{N_S - N_a}{N_R - N_a} = \frac{-T_R}{T_S}$$

$$\frac{100 - N_a}{0 - N_a} = \frac{-80}{20}$$

$$100 - N_a = 4 N_a$$

$$5 N_a = 100$$

$$N_a = 20 \text{ rpm (CW)}$$

2.5 Sol.

$$\text{Circular pitch: } P = \frac{\pi D}{T}$$

$$\text{Diametral pitch} = \frac{T}{D}$$

$$\text{Circular pitch} \times \text{Diametral pitch}$$

$$= \frac{\pi \cdot D}{T} \times \frac{T}{D} = \pi$$



CONTENTS

1.	Static, Dynamic Loading and Failure Theories	22
2.	Fatigue Strength and S-N Diagram	24
3.	Bolted Riveted and Welded Joint	25
4.	Bearings, Shafts and Keys	26
5.	Gears	27
6.	Brakes, Clutches and Ropes	28

Static, Dynamic Loading and Failure Theories

1.1 In the design of shafts made of ductile materials subjected to twisting moment and bending moment, the recommended theory of failure is

- (a) maximum principal stress theory
- (b) maximum principal strain theory
- (c) maximum shear stress theory
- (d) maximum strain energy theory

[1988 : 1 Mark]

1.2 Torque to weight ratio for a circular shaft transmitting power is directly proportional to the

- (a) square root of the diameter
- (b) diameter
- (c) square of the diameter
- (d) cube of the diameter

[1991 : 1 Mark]

1.3 A large uniform plate containing a rivet hole is subjected to uniform uniaxial tension of 95 MPa. The maximum stress in the plate is

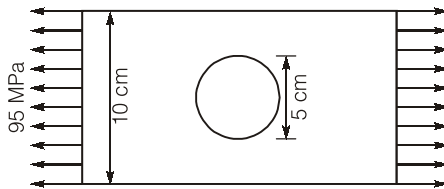

- (a) 100 MPa
- (b) 285 MPa
- (c) 190 MPa
- (d) Indeterminate

[1992 : 1 Mark]

1.4 The outside diameter of a hollow shaft that is twice its inside diameter the ratio of its torque carrying capacity to that of a solid shaft of the same material and the same outside diameter is

- (a) 15/16
- (b) 3/4
- (c) 1/2
- (d) 1/16

[1993 : 1 Mark]

1.5 Two shafts *A* and *B* are made of the same material. The diameter of shaft *B* is twice that of shaft *A*. The ratio of power which can be transmitted by shaft *A* to that of shaft *B* is

- (a) 1/2
- (b) 1/4
- (c) 1/8
- (d) 1/16

[1994 : 1 Mark]



Answers Static, Dynamic Loading and Failure Theories

1.1 (c) 1.2 (b) 1.3 (c) 1.4 (a) 1.5 (c)

Explanations Static, Dynamic Loading and Failure Theories

1.1 (c)

For ductile materials, maximum shear stress theory is considered.

1.2 (b)

$$T = \frac{\pi}{16} d^3 \tau; \quad W = \frac{\pi d^2}{4} \rho l$$

$$\frac{T}{W} = \frac{\pi}{16} \frac{d^3 \tau}{\frac{\pi d^2}{4} \rho l}$$

$$\frac{T}{W} \propto d$$

1.3 (c)

Tensile load acting on the plate,

$$P = 95 \times 100 \times t = 9500t \text{ N}$$

Maximum stress in the plate,

$$\begin{aligned} \sigma_{\max} &= \frac{P}{(b-d)t} = \frac{9500t}{(100-50)t} \\ &= \frac{9500t}{50t} = 190 \text{ MPa} \end{aligned}$$

1.4 (a)

For hollow shaft,

$$T_h = \frac{\pi}{32} \left(d^4 - \frac{d^4}{16} \right) \frac{2}{d} \tau$$

For solid shaft

$$T_s = \frac{\pi}{16} d^3 \tau$$

$$\frac{T_h}{T_s} = \frac{15}{16}$$

1.5 (c)

$$\text{Power} = T \times \omega$$

$$\text{For shaft A, } T_A = \frac{\pi}{16} d^3 \tau$$

$$\text{For shaft B, } T_B = \frac{\pi}{16} (2d)^3 \tau$$

$$\frac{P_A}{P_B} = \frac{T_A}{T_B} = \frac{1}{8}$$



- 2.1 A ductile material having an endurance limit of 196 N/mm^2 and the yield point at 294 N/mm^2 is stressed under variable load. The maximum and minimum stresses are 147 N/mm^2 and 49 N/mm^2 . The fatigue stress concentration factor is 1.32. The available factor of safety for this loading is
 (a) 3.0 (b) 1.5
 (c) 1.33 (d) 4.0 [1987 : 2 Marks]
- 2.2 Stress concentration in a machine component of a ductile material is not so harmful as it is in a brittle material because
 (a) in ductile material local yielding may distribute stress concentration
 (b) ductile material has larger Young's material
 (c) Poisson's ratio is larger in ductile materials
 (d) Modulus of rigidity is larger in ductile materials [1989 : 1 Mark]
- 2.3 The process of shot peening increases the fatigue life of steel springs mainly because it results in
 (a) surface hardening
 (b) increased stiffness of the material
 (c) structural changes in the material
 (d) residual compression at the surface [1990 : 1 Mark]
- 2.4 In a shaft with a transverse hole, as the hole to the shaft diameter ratio (increase/decrease), the torsional stress concentration factor (increases/ decreases) [1991 : 1 Mark]
- 2.5 Fatigue strength of rod subjected to cyclic axial force is less than that of a rotating beam of the same dimensions subjected to steady lateral force. [True / False] [1992 : 1 Mark]
- 2.6 The yield strength of a steel shaft is twice its endurance limit. Which of the following torque fluctuations represent the most critical situation according to Soderberg criterion?
 (a) $-T$ to $+T$ (b) $-T/2$ to $+T$
 (c) 0 to $+T$ (d) $+T/2$ to $+T$ [1993 : 1 Mark]

■ ■ ■ ■

Answers Fatigue Strength and S-N Diagram

2.1 (b) 2.2 (a) 2.3 (d) 2.4 (Increase, decrease) 2.5 (True) 2.6 (a)

Explanations Fatigue Strength and S-N Diagram

2.1 (b)

Consider Soderberg equation

$$\frac{\tau_a}{S_e} + \frac{\tau_m}{S_y} = \frac{1}{\text{FOS}}$$

$$\tau_a = \frac{147 - 49}{2} = \frac{98}{2} = 49 \text{ MPa}$$

$$\tau_m = \frac{147 + 49}{2} = \frac{196}{2} = 98 \text{ MPa}$$

$$S_e = \frac{196}{1.32} = 147.48 \text{ MPa}$$

$$\frac{49}{147.48} + \frac{98}{294} = \frac{1}{\text{FOS}}$$

or $\text{FOS} = 1.5$

2.2 (a)

Local yielding reduces stress concentration effect.

2.3 (d)

Shot peening process uses small shots to produce residual compression stress at surface. It improves fatigue life of springs.

2.4 Sol.

Increase, decrease

2.5 Sol.

True

2.6 (a)

$$\frac{\tau_a}{S_e} + \frac{\tau_m}{S_y} = \frac{1}{\text{FOS}} \Rightarrow \frac{\tau_a}{1} + \frac{\tau_m}{2} = \frac{S_e}{\text{FOS}}$$

τ_a is highest in case of (a).

■ ■ ■ ■

- 3.1 Weldments in fabricated steel beams are designed for
- (a) bending stresses at the flange
 - (b) shear stresses in transverse plane
 - (c) combination of bending and shear
 - (d) none of these because in fabricated beams welds not to get stressed

[1987 : 1 Mark]

■ ■ ■ ■

Answers Bolted Riveted and Welded Joint

3.1 (c)

Explanations Bolted Riveted and Welded Joint

3.1 (c)

Steel beams undergoes both bending and shear loads. So, weldment for fabrication should be designed for combined loading.

■ ■ ■ ■

4

Bearings, Shafts and Keys

4.1 The expected life of a ball bearing subjected to a load of 9800 N and working at 1000 rpm is 3000 hours. What is the expected life of the same bearing for a similar load of 4900 N and speed of 2000 rpm?

- (a) Unchanged (b) 12000 hours
(c) 1500 hours (d) 6000 hours

[1987 : 1 Mark]

4.2 If the load on a ball bearing is reduced to half, the life of the ball bearing will

- (a) increase 8 times (b) increase 4 times
(c) increase 2 times (d) not change

[1988 : 1 Mark]

4.3 Match the rolling element bearings with the most appropriate loading condition

Bearing-type

- (a) Ball bearing
(b) Roller bearing
(c) Needle bearing
(d) Taper roller bearing

Loading condition

- (p) Tangential load
(q) Radial load
(r) Heavy radial load with impact
(s) Light radial load with space limitation
(t) Heavy radial and axial load
(u) Fatigue load

[1992 : 1 Mark]

4.4 Starting friction is low in

- (a) hydrostatic lubrication
(b) hydrodynamic lubrication
(c) mixed (or semi fluid) lubrication
(d) boundary lubrication

[1992 : 1 Mark]

4.5 Spherical roller bearings are normally used

- (a) for increased radial load
(b) for increased thrust load
(c) when there is less radial load
(d) to compensate for angular misalignment

[1992 : 1 Mark]



Answers Bearing, Shafts and Keys

4.1 (b) 4.2 (a) 4.3 (a - q, b - r, c - s, d - t) 4.4 (a) 4.5 (d)

Explanations Bearing, Shafts and Keys

4.1 (b)

$$L(P)^3 = \text{Constant}$$

$$\frac{L_1}{L_2} = \left(\frac{P_2}{P_1}\right)^3$$

$$\Rightarrow \frac{1000 \times 60 \times 3000}{2000 \times 60 \times t_2} = \left(\frac{4900}{9800}\right)^3$$

$$t_2 = 12000 \text{ hrs}$$

4.3 Sol.

$$a - q, b - r, c - s, d - t$$

4.4 (a)

Due to thick fluid friction from the beginning.



4.2 (a)

$$LP^3 = K$$

$$\Rightarrow L_1 P_1^3 = L_2 \left(\frac{P_1}{2}\right)^3 \quad \left[P_2 = \frac{P_1}{2}\right]$$

$$\Rightarrow L_2 = 8L_1$$

5.1 In order to test the efficiency of reducer gear train 1 kW input was given at the input end at a speed of 1440 rpm and at the output end the measured torque was 56.36 Nm. If the ratio of speed reduction in this unit is 10 : 1, the efficiency is about

- (a) 78% (b) 85%
(c) 63% (d) 96%

[1989 : 2 Mark]



Answers **Gears**

5.1 (b)

Explanations **Gears**

5.1 (b)

Speed reduction = 10 : 1

$$\text{Output speed} = \frac{1440}{10} = 144 \text{ rpm}$$

$$\begin{aligned} \text{Output power} = T\omega &= 56.36 \times \frac{2\pi \times 144}{60} \\ &= 849.88 \text{ W} \end{aligned}$$

$$\begin{aligned} \% \text{ efficiency} &= \frac{\text{Output}}{\text{Input}} \times 100 = \frac{849.88}{1000} \times 100 \\ &= 84.9\% \approx 85\% \end{aligned}$$



6

Brakes, Clutches and Ropes

- 6.1 Axial operation jaw clutches having self-locking tooth profile
- (a) can be disengaged at any speed
 - (b) can be disengaged only when unloaded
 - (c) can be engaged only when unloaded
 - (d) can work only with load

[1987 : 1 Mark]



Answers Brakes, Clutches and Ropes

6.1 (c)

Fluid Mechanics and Hydraulic Machines

UNIT

V

CONTENTS

1.	Fluid Statics	30
2.	Fluid Kinematics	32
3.	Fluid Dynamics	36
4.	Viscous, Turbulent Flow & Boundary Layer Theory	39
5.	Turbines and Pumps	42

1.1 A circular plate 1 m in diameter is submerged vertically in water such its upper edge is 8 m below the free surface of water. The total hydrostatic pressure force on one side of plate is

- (a) 6.7 kN (b) 65.4 kN
(c) 45.0 kN (d) 77.0 kN

[1988 : 2 Marks]

1.2 The cross-sectional area of one limb of a U-tube manometer (figure shown below) is made 500 times larger than the other, so that the pressure difference between the two limbs can be determined by measuring h on one limb of the manometer. The percentage error involved is

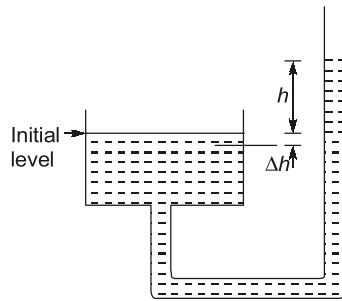

- (a) 1.0 (b) 0.5
(c) 0.2 (d) 0.05 [1990 : 2 Marks]

1.3 Shown below are three cylindrical gates which restrain water in a 2-D channel. Which gate experiences the maximum vertical component, the minimum vertical component and the maximum horizontal component of the hydrostatic force?

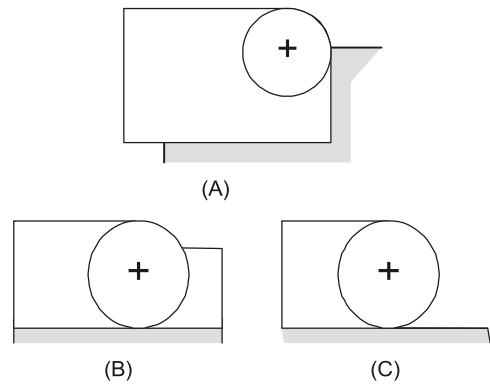

[1993 : 1 Mark]

1.4 Bodies in flotation to be in stable equilibrium the necessary and sufficient condition is that the centre of gravity is located below the

[1994 : 1 Mark]



Answers Fluid Statics

1.1 (b) 1.2 (c)

Explanations Fluid Statics

1.1 (b)

Given data:

$$d = 1 \text{ m}$$

$$\bar{h} = 8 + \frac{d}{2} = 8 + \frac{1}{2} = 8.5 \text{ m}$$

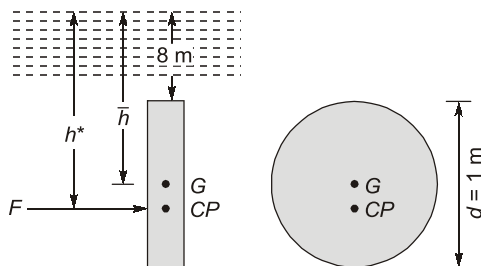

Surface area,

$$A = \frac{\pi}{4} d^2 = \frac{3.14}{4} \times 1^2 = 0.785 \text{ m}^2$$

Total hydrostatic pressure force,

$$F = \rho g \bar{h} A = 1000 \times 9.81 \times 8.5 \times 0.785 \\ = 65457.22 \text{ N} \approx 65.45 \text{ kN}$$



POINTS TO REMEMBER

Here, it is important to note that height \bar{h} is taken as the distance between free surface and the centre of gravity of plate, but the hydrostatic force

will act on the centre of pressure. And centre of pressure h^* can be calculated as:

$$h^* = \bar{h} + \frac{I_{CG} \sin^2 \theta}{A \bar{h}}$$

Here, in this problem as plate is vertical.

So, $\theta = 90^\circ$.

1.2 (c)

Method I:

Volume drop in larger limb
= Volume rise in smaller limb

$$A_1 \Delta h = A_2 h$$

or
$$\frac{\Delta h}{h} = \frac{A_2}{A_1} = \frac{1}{500}$$

$$\% \text{ error} = \frac{\Delta h}{h} \times 100 = \frac{1}{500} \times 100 = 0.2\%$$

Method II:

Given that: $A_1 = 500 A_2$

By volume conservation $A_1 \Delta h = A_2 h$

$$\Delta h = \frac{A_2}{A_1} h = \frac{A_2 h}{500 A_2}$$

$$\Delta h = \frac{h}{500}$$

Actual pressure difference,

$$\begin{aligned} \Delta p_{\text{actual}} &= \rho g(h + \Delta h) \\ &= \rho g h \left(1 + \frac{1}{500} \right) \end{aligned}$$

$$\begin{aligned} \% \text{ error} &= \frac{\Delta p_{\text{actual}} - \Delta p_{\text{measured}}}{\Delta p_{\text{measured}}} \times 100 \\ &= \frac{\left(1 + \frac{1}{500} \right) - 1}{1} \times 100 \\ &= \frac{1}{500} \times 100 = 0.2\% \end{aligned}$$

1.3 Sol.

Maximum vertical component: In gate *A*, bottom half of the gate has fluid with higher pressure and also as we can see, bottom right and side fluid is not open to atmosphere is in gate *B*. So, maximum vertical component will be experienced by the gate *A*.

Minimum vertical component: In gate *C*, only left hand side bottom half is exposed to fluid pressure and the top half part has same condition for all the three gates. So minimum vertical component will be experienced by the gate *C*.

Maximum horizontal component: As it is shown in figure, all the three gates have same condition for the left portion of the gate and only gate *C* has no fluid on the right portion. So maximum horizontal component will be experienced by gate *C*.

1.4 Sol.

For stable equilibrium condition centre of gravity should be below metacentre.



2.1 The velocity potential function for a source varies with the distance r as

- (a) $1/r$ (b) $1/r^2$
(c) e^r (d) $\ln r$

[1987 : 1 Mark]

2.2 A streamlined body is defined as a body about which

- (a) The flow is laminar
(b) The flow is along the streamlines
(c) The flow separation is suppressed
(d) The drag is zero

[1987 : 1 Mark]

2.3 The Newtonian fluid has the following velocity field:

$$\vec{V} = x^2y\hat{i} + 2xy^2z\hat{j} - yz^3\hat{k}$$

The rate shear deformation ϵ_{yz} at the point $x = -2$, $y = -1$ and $z = 2$ for the given flow is

- (a) -6 (b) -2
(c) -12 (d) 4

[1988 : 2 Marks]

2.4 The stream function in a two dimensional flow field is given by $\psi = x^2 - y^2$. The magnitude of the velocity at point $(1, 1)$ is

- (a) 2 (b) $2\sqrt{2}$
(c) 4 (d) 8

[1989 : 2 Marks]

2.5 Shown below are three pipe sections through which water flows as shown. Option a to d below pertain to the direction of the net force on the pipe section due to the flow of water.

- (a) 45° to both +ve x and +ve y axes
(b) 45° to both -ve x and +ve y axes
(c) 45° to both +ve x and -ve y axes
(d) 45° to both -ve x and -ve y axes

State which of the options indicate the correct direction of force for pipe 1, pipe 2 and pipe 3

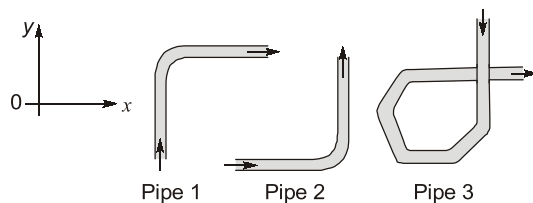

[1993 : 1 Mark]

2.6 A velocity field is given as

$$\vec{V} = 3x^2y\hat{i} - 6xyz\hat{k}$$

where x , y , z are in m and V in m/s . Determine if

- (i) It represents an incompressible flow
(ii) The flow is irrotational
(iii) The flow is steady

[1993 : 2 Marks]

2.7 Streamlines, path lines and streak lines are virtually identical for

- (a) Uniform flow (b) Flow of ideal fluids
(c) Steady flow (d) Nonuniform flow

[1994 : 1 Mark]

2.8 In a flow field the stream lines and equipotential lines

- (a) Are parallel
(b) Cut at any angle
(c) Are orthogonal every where in the field
(d) Cut orthogonal except at the stagnation points

[1994 : 1 Mark]

2.9 For a fluid element in a two dimensional flow field ($x-y$ plane), if it will undergo

- (a) Translation only
(b) Translation and rotation
(c) Translation and deformation
(d) Deformation only

[1994 : 1 Mark]

2.10 Existence of velocity potential implies that

- (a) Fluid is in continuum
(b) Fluid is irrotational
(c) Fluid is ideal
(d) Fluid is compressible

[1994 : 1 Mark]

2.11 Circulation is defined as line integral of tangential component of velocity about a _____ (fill in the blanks)

[1994 : 1 Mark]



Answers Fluid Kinematics

- 2.1 (d) 2.2 (c) 2.3 (a) 2.4 (b) 2.5 (1-d, 2-d, 3-b) 2.6 (0) 2.7 (c)
 2.8 (d) 2.9 (c) 2.10 (b) 2.11 (Closed contour in flow field.)

Explanations Fluid Kinematics

2.1 (d)

The radial velocity u_r at any radius r is:

or
$$u_r = \frac{q}{2\pi r}$$

where, q = Volume flow rate per unit depth

The velocity component in polar co-ordinates in terms of velocity potential function are:

$$u_\theta = -\frac{1}{r} \frac{d\phi}{d\theta}; u_r = \frac{-\partial\phi}{\partial r}$$

where, u_r = Radial direction velocity

u_θ = Tangential direction velocity

Also,
$$u_r = \frac{-\partial\phi}{\partial r} = \frac{q}{2\pi r}$$

$$\int \partial\phi = \int -\frac{q}{2\pi r} dr$$

$$\phi = -\frac{q}{2\pi} \ln r$$

So, ϕ varies with the distance r as $\ln r$ and q is constant.



POINTS TO REMEMBER

A source flow is the flow coming from a point and moving out radially in all direction of a plane at uniform rate.

2.2 (c)

Flow separation is suppressed by giving the profile of the body a streamlined shape, because:

- (i) The streamlined shape has an elongated shape in the rear part to reduce the magnitude of the pressure gradient.
- (ii) The optimum contour for a streamlined body is the one for which the wake zone is very narrow and form drag is minimum

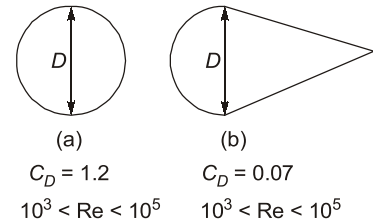

Fig: Reduction of drag coefficient (C_D) by giving the profile a streamlined shape.

2.3 (a)

$$\vec{v} = x^2y\hat{i} + 2xy^2z\hat{j} - yz^3\hat{k}$$

Shear strain,

$$\epsilon_{yz} = \frac{1}{2} \left(\frac{\partial v}{\partial z} + \frac{\partial w}{\partial y} \right) = \frac{1}{2} (2xy^2 - z^3)$$

At $(-2, -1, 2)$, we get

$$\epsilon_{yz} = \frac{1}{2} (-4 - 8) = -6$$

2.4 (b)

Given data:

Stream function, $\psi = x^2 - y^2$

The velocity componentry u and v in the direction of x and y are given by

$$u = -\frac{\partial\psi}{\partial y} = -\frac{\partial}{\partial y} (x^2 - y^2) = 2y$$

or
$$v = \frac{\partial\psi}{\partial x} = \frac{\partial}{\partial x} (x^2 - y^2) = 2x$$

The velocity at point $(1, 1)$,

$$\begin{aligned} \vec{v} &= u\hat{i} + v\hat{j} = 2y\hat{i} + 2x\hat{j} \\ &= 2 \times 1\hat{i} + 2 \times 1\hat{j} = 2\hat{i} + 2\hat{j} \end{aligned}$$

The magnitude of the velocity,

$$V = \sqrt{(2)^2 + (2)^2} = \sqrt{4+4} = \sqrt{8} = 2\sqrt{2}$$

2.5 Sol.

Force exerted by the water on the pipe,
 For pipe-1

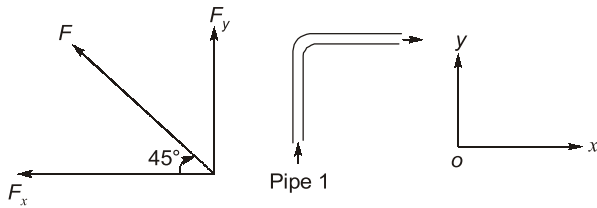

For pipe-1 → (Option (b))

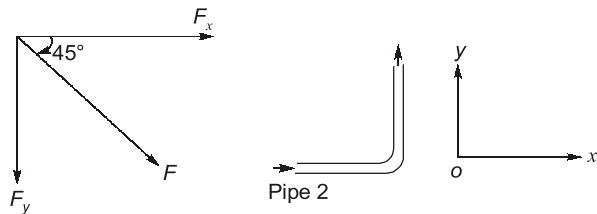

For pipe-2 → (Option (c))

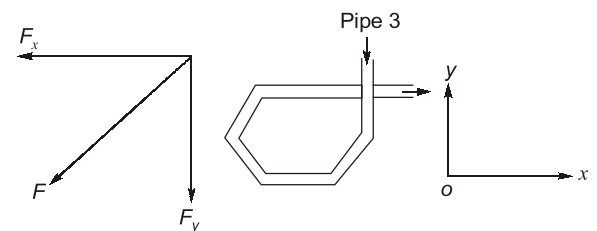

For pipe-3 → (Option (d))

2.6 Sol.

(i) For an incompressible flow:

$$\frac{\partial u}{\partial x} + \frac{\partial v}{\partial y} + \frac{\partial w}{\partial z} = 0$$

$$6xy + 0 - 6xy = 0$$

Hence given velocity field represents an incompressible flow.

(ii) Flow is irrotational:

Vorticity, $\xi = 2 \times$ rotational component $= 2 \times \omega$

$$= \nabla \times \vec{V}$$

$$= \begin{vmatrix} \hat{i} & \hat{j} & \hat{k} \\ \frac{\partial}{\partial x} & \frac{\partial}{\partial y} & \frac{\partial}{\partial z} \\ 3x^2y & 0 & -6xyz \end{vmatrix}$$

$$\xi = -6xz \hat{i} + 6yz \hat{j} - 6x^2 \hat{k}$$

i.e. $\xi \neq 0$

Since vorticity is not zero, so flow is rotational.

(iii) For steady flow:

Since there is no component of velocity.

$$\left(\frac{\partial v}{\partial t} \right)_{x,y,z} = 0$$

i.e. the given velocity field is independent of time hence steady flow.



POINTS TO REMEMBER

- For irrotational flow, the vorticity is zero, at all points in the flow region while for rotational flow, vorticity is non-zero.
- Flow outside the boundary layer has irrotational characteristic while that within the boundary layer has rotational characteristic.

2.8 (d)

For equi-potential line:

$$d\phi = 0$$

$$-udx - vdy = 0$$

$$\frac{dy}{dx} = -\frac{u}{v}$$

Hence, slope of equipotential line,

$$\left(\frac{dy}{dx} \right)_{\phi = \text{constant}} = -\frac{u}{v} \quad \dots(i)$$

For equi-stream function line:

$$d\psi = 0$$

$$vdx - udy = 0 \quad [\text{stream line}]$$

$$\frac{dx}{u} = \frac{dy}{v}$$

$$\text{and } \frac{dy}{dx} = \frac{v}{u}$$

Hence slope of equi-stream line,

$$\left(\frac{dy}{dx} \right)_{\psi = \text{constant}} = \frac{v}{u} \quad \dots(ii)$$

From equation (i) and (ii), we get

$$\begin{aligned} \left(\frac{dy}{dx} \right)_{\phi = \text{constant}} \times \left(\frac{dy}{dx} \right)_{\psi = \text{constant}} \\ = \frac{-u}{v} \times \frac{v}{u} = -1 \end{aligned}$$

Hence, stream lines and equipotential lines are orthogonal to each other except at the stagnation points.

2.10 (b)

Velocity potential function (ϕ):

Velocity component in x , y and z direction are:

$$u = \frac{-\partial\phi}{\partial x}, v = \frac{-\partial\phi}{\partial y}, w = \frac{-\partial\phi}{\partial z}$$

Flow always occurs in the direction of decreasing potential.

Velocity potential function exists only for irrotational flow.



POINTS TO REMEMBER

As we know that Laplace equation is given as:

$$\frac{\partial^2\phi}{\partial x^2} + \frac{\partial^2\phi}{\partial y^2} = 0$$

So, if velocity potential function satisfies Laplace equation then it also satisfies continuity equation and hence flow is possible.

2.11 Sol.

Closed contour in flow field.



- 3.1 A mercury manometer is attached to a section of the pipe shown in the figure. Mercury levels are indicated when there is no water flowing through the pipe. When water starts flowing through the pipe continuously at constant rate in the direction of the arrow, the level of mercury at *B* _____.

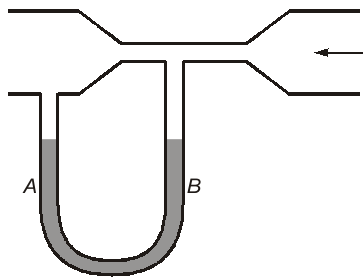

[1987 : 2 Marks]

- 3.2 Water flows through a pipe of diameter 0.30 m. What would be the velocity *V* for the conditions shown in the figure below?

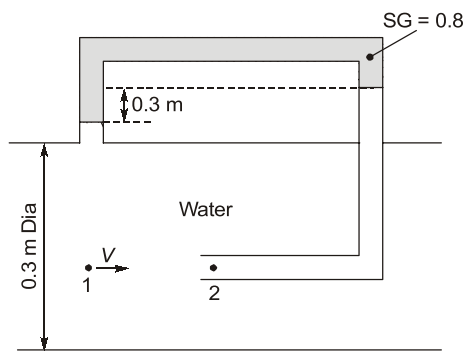

[1988 : 2 Marks]

- 3.3 In a hand operated liquid sprayer (figure shown below) the liquid from the container rises to the top of the tube because of

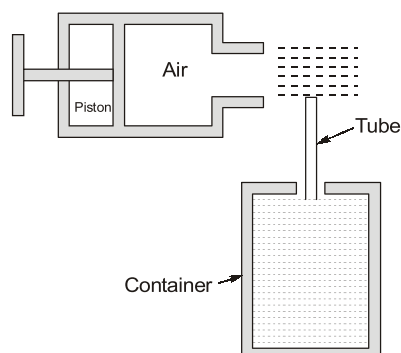

- (a) Capillary effect
- (b) Suction produced by the air jet at the top end of tube
- (c) Suction produced by the piston during the backward stroke
- (d) Pumping of the air into the container

[1990 : 1 Mark]

- 3.4 A jet of water issues from a nozzle with a velocity 20 m/s and it impinges normally on a flat plate moving away from it at 10 m/s. The cross-sectional area of the jet is 0.01 m^2 , and the density of water = 1000 kg/m^3 . The force developed on the plate is

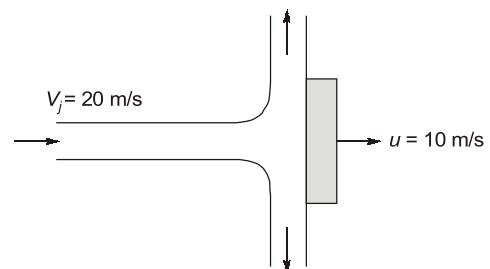

- (a) 1000 N
- (b) 100 N
- (c) 10 N
- (d) 2000 N

[1990 : 2 Marks]

- 3.5 A fan in the duct shown below sucks air from the ambient and expels it as a jet at 1 m/s to the ambient. Determine the gauge pressure at the point marked as *A*. Take the density of air as 1 kg/m^3 .

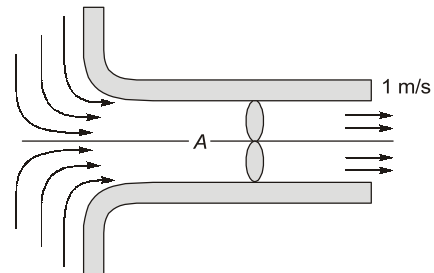

[1993 : 2 Marks]

- 3.6 Bernoulli's equation can be applied between any two points on a stream line for a rotational flow field. State : (T/F) [1994 : 1 Mark]

- 3.7 In a venturimeter, the angle of the diverging section is more than that of converging section. State: (T/F) [1994 : 1 Mark]

Answers Fluid Dynamics

3.1 (Rises) 3.2 (1.084) 3.3 (b) 3.4 (a) 3.5 (-0.5) 3.6 (True) 3.7 (False)

Explanations Fluid Dynamics

3.1 Sol.

Level of mercury at *B* rises because when water starts flowing, pressure at arm *B* will be lower than that of *A*. Also we can find it by using Bernoulli's equation, that the pressure head at *A* will be more than that of *B*. Hence level of mercury rises at *B* and lower at *A*.

3.2 Sol.

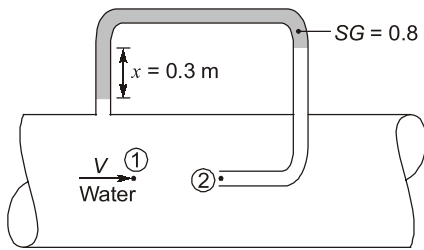

Manometric reading,

$$x = 0.3 \text{ m}$$

Specific gravity of manometer fluid,

$$S_{\text{mano}} = 0.8$$

Density of manometer fluid,

$$\rho_{\text{mano}} = 0.8 \times 1000 \text{ kg/m}^3 = 800 \text{ kg/m}^3$$

$$\therefore h = x \left[1 - \frac{\rho_{\text{mano}}}{\rho_{\text{pipe}}} \right] = 0.3 \left[1 - \frac{800}{1000} \right]$$

$$= 0.06 \text{ m of water}$$

Velocity of point 1,

$$V = \sqrt{2gh} = \sqrt{2 \times 9.81 \times 0.06} = 1.084 \text{ m/s}$$



POINTS TO REMEMBER

This problem is based on the pitot tube.

Pitot tube: It is a device which is basically used to measure the local velocities in the pipe flow.

Here, velocity at point 1: ($V = \sqrt{2gh}$) is theoretical velocity.

- For actual velocity multiply V by the C_v (coefficient of velocity).
- Value of C_v for pitot tube is 0.97 to 0.99
Hence

$$V_{\text{actual}} = C_v V = C_v \sqrt{2gh} = 0.97 \times 1.084 = 1.05 \text{ m/s}$$

3.3 (b)

Jet of air produces suction at the top end of the tube and due to which liquid rises in the container.

3.4 (a)

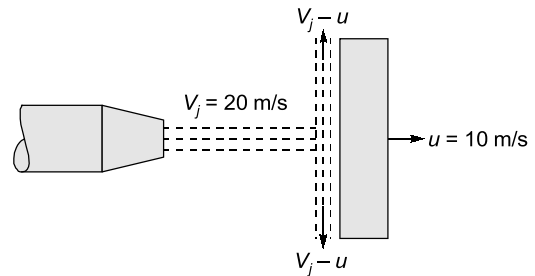

$$V_j = 20 \text{ m/s}, u = 10 \text{ m/s}, a = 0.01 \text{ m}^2$$

$$\rho = 1000 \text{ kg/m}^3$$

The force developed on the plate,

$$F_x = \rho a (V_j - u)^2 = 1000 \times 0.01 (20 - 10)^2 = 1000 \text{ N}$$

3.5 Sol.

Applying Bernoulli's equation between sections (1) [at suction] and *A*

$$\frac{\rho_1}{\rho g} = \frac{\rho_A}{\rho g} + \frac{V_A^2}{2g}$$

$$\frac{\rho_A - \rho_1}{\rho g} = -\frac{V_A^2}{2g}$$

$$\rho_1 = \rho_{\text{ambient}}$$

$$\therefore \rho_A - \rho_1 = (\rho_A)_{\text{gauge}}$$

$$\therefore \frac{(\rho_A)_{\text{gauge}}}{\rho g} = -\frac{V_A^2}{2g}$$

$$(\rho_A)_{\text{gauge}} = \frac{1 \times 1^2}{2} = -0.5 \text{ N/m}^2$$

3.6 Sol.**True**

For energy conservation in rotational flow field:

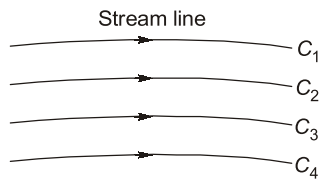
In irrotational flow: $C_1 = C_2 = C_3 = C_4$

So, Bernoulli's equation is valid because irrotational flow is an assumption for Bernoulli's equation.

In rotational flows: $C_1 \neq C_2 \neq C_3 \neq C_4$

But, Bernoulli's equation can be applied in rotational fluid flows between the any two points which are on the same stream line because at same stream line it is constant.

3.7 Sol.**False**

In a venturimeter, the angle of the diverging section is less than that of converging section.

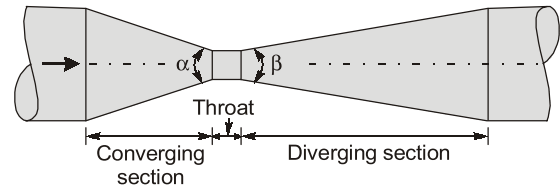
**Venturimeter**Angle of the converging section,
 $\alpha = 19^\circ$ to 23° Angle of the diverging section,
 $\beta = 5^\circ$ to 7° 

Viscous, Turbulent Flow & Boundary Layer Theory

- 4.1 In the case of turbulent flow of a fluid through a circular tube (as compared to the case of laminar flow at the same flow rate) the maximum velocity is, shear stress at the wall is, and the pressure drop across a given length is The correct words for the blanks are, respectively
- higher, higher, higher
 - higher, lower, lower
 - lower, higher, higher
 - lower, higher, lower

[1987 : 2 Marks]

- 4.2 The parameters which determine the friction factor for turbulent flow in a rough pipe are
- Froude number and relative roughness
 - Froude number and Mach number
 - Reynolds number and relative roughness
 - Mach number and relative roughness

[1988 : 1 Mark]

- 4.3 The discharge in m^3/s for laminar flow through a pipe of diameter 0.04 m having a centre line velocity of 1.5 m/s is

- $\frac{3\pi}{50}$
- $\frac{3\pi}{2500}$
- $\frac{3\pi}{5000}$
- $\frac{3\pi}{10000}$

[1988 : 2 Marks]

- 4.4 The predominant forces acting on an element of fluid in the boundary layer over a flat plate in a uniform parallel stream are
- Viscous and pressure forces
 - Viscous and inertia forces
 - Viscous and body forces
 - Inertial and pressure forces

[1990 : 1 Mark]

- 4.5 Shown below are three tanks, tank 1 without an orifice tube and tanks 2 and 3 with orifice tubes as shown. Neglecting losses and assuming the diameter of orifice to be much less than that of the tank, write expressions for the exit velocity in each of the three tanks.

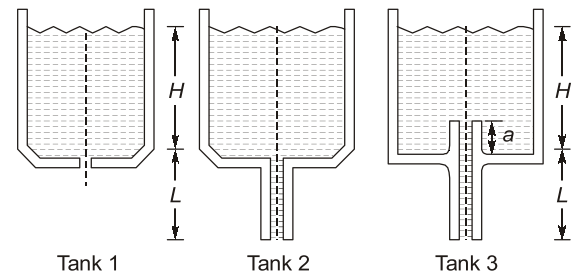

[1993 : 2 Marks]

- 4.6 Prandtl's mixing length in turbulent flow signifies
- the average distance perpendicular to the mean flow covered by the mixing particles
 - the ratio of mean free path to characteristic length of the flow field
 - the wavelength corresponding to the lowest frequency present in the flow field
 - the magnitude of turbulent kinetic energy

[1994 : 1 Mark]

- 4.7 For a fully developed flow through a pipe, the ratio of the maximum velocity to the average velocity is ____ (fill in the blanks)

[1994 : 1 Mark]

- 4.8 The necessary and sufficient condition which brings about separation of boundary layer is

$$\frac{dP}{dx} > 0 \text{ (True/False)}$$

[1994 : 1 Mark]

- 4.9 As the transition from laminar to turbulent flow is induced in a cross flow past a circular cylinder the value of the drag coefficient drops.

[1994 : 1 Mark]

- 4.10 Fluid is flowing with an average velocity of V through a pipe of diameter d . Over a length of L ,

the head loss is given by $\frac{fLV^2}{2gD}$. The friction factor,

f for laminar flow in terms of Reynolds number (Re) is (fill in the blanks)

[1994 : 2 Marks]

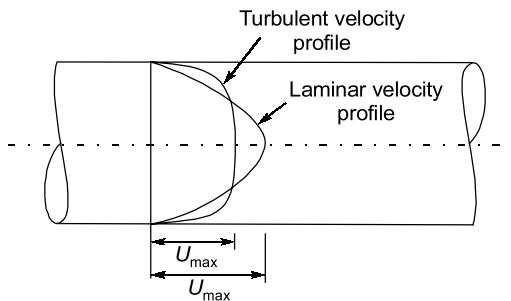
Answers Viscous, Turbulent Flow and Boundary Layer Theory4.1 (c) 4.2 (c) 4.3 (d) 4.4 (b) 4.5 ($\sqrt{2gH}$, $\sqrt{2g(H+L)}$, $\sqrt{2g(H+L)}$)4.6 (a) 4.7 (2) 4.8 (True) 4.9 (True) 4.10 ($f = \frac{64}{Re}$)**Explanations Viscous, Turbulent Flow and Boundary Layer Theory****4.1 (c)**

As compared to laminar flow,

- Turbulent flow has lower maximum velocity.
- Turbulent flow has higher shear stress.
- Turbulent flow has higher pressure drop.

4.2 (c)

Friction factor for turbulent flow:

For smooth pipes,

$$f = \frac{0.3164}{Re^{1/4}} \quad \text{upto } Re = 10^5$$

For rough pipes,

$$\frac{1}{\sqrt{f}} = 2.0 \log_{10} \left(\frac{R}{K} \right) + 1.74$$

**POINTS TO REMEMBER**

- In case of turbulent flow, friction factor (f) depends on Reynolds number and relative roughness.
- For smooth pipes, the friction factor (f) depends only on Reynolds number
- For rough pipes, the friction factor (f) depends on relative roughness.
- In turbulent flow, a smooth pipe and rough pipe shall have the same friction factor if the flow is in transition zone from smooth to rough pipe.
- here in this problem only option (c) matches the results.

4.3 (d)

$$d = 0.04 \text{ m}$$

Centre line velocity *i.e.*, maximum velocity,

$$U_{\max} = 1.5 \text{ m/s}$$

also $U_{\max} = 2$ times average velocity for laminar flow through pipe

$$U_{\max} = 2\bar{u}$$

$$\therefore 1.5 = 2\bar{u}$$

$$\text{or } \bar{u} = \frac{1.5}{2} \text{ m/s}$$

Discharge: $Q =$ Cross-sectional area of pipe \times Average velocity

$$= \frac{\pi}{4} d^2 \times \bar{u} = \frac{\pi}{4} \times (0.04)^2 \times \frac{1.5}{2}$$

$$= \frac{\pi}{4} \times \frac{4}{100} \times \frac{4}{100} \times \frac{1.5}{2}$$

$$= \frac{3\pi}{10000} \text{ m}^3/\text{s}$$

4.5 Sol.

$$\text{Exit velocity for tank 1: } V = \sqrt{2gH}$$

$$\text{Exit velocity for tank 2: } V = \sqrt{2g(H+L)}$$

$$\text{Exit velocity for tank 3: } V = \sqrt{2g(H+L)}$$

4.6 (a)

For fully developed turbulent flow,

$$\text{Shear stress, } \tau = \rho \mu' v'$$

where μ' and v' = fluctuating component of velocity in the direction of x and y due to turbulence.But it is very difficult to determine μ' and v' . So Prandtl represented a hypothesis known as Prandtl mixing length, l which is the average distance perpendicular to then mean flow covered by the mixing particle.

$$\mu' = v' = l \frac{du}{dy}$$

$$\text{Shear stress, } \tau = \rho l^2 \left(\frac{du}{dy} \right)^2$$

4.7 Sol.

For the fully developed laminar flow through a circular pipe,

$$\text{Average velocity} = \frac{\text{maximum velocity}}{2}$$

$$V_{\text{avg}} = \frac{V_{\text{max}}}{2}$$

$$\therefore \frac{V_{\text{max}}}{V_{\text{avg}}} = 2$$

**POINTS TO REMEMBER**

- Maximum velocity occur at the axis of the pipe.
- The point where local velocity is equal to average velocity is given by:

$$r = \frac{R}{\sqrt{2}} = 0.707R$$

4.8 Sol.

True

Boundary layer separation is caused by adverse

pressure gradient $\left(\frac{dp}{dx} > 0\right)$ and the condition

of the separation of boundary layer are:

$$(i) \frac{dp}{dx} > 0$$

$$(ii) \left(\frac{dv}{dy}\right)_{y=0} = 0 ; \text{ flow is on verge of seapration}$$

$$\left(\frac{dv}{dy}\right)_{y=0} < 0 ; \text{ flow is separated}$$

4.9 Sol.

True

**POINTS TO REMEMBER**

- When Reynold's number, $Re < 1$, drag coefficient (C_D) is inversely proportional to Reynold's number.
- When Reynold's number increases from 1 to 2000, drag coefficient (C_D) decreases and reaches a minimum value of 0.95 at Reynold number, $Re = 2000$.
- When Reynolds number increases from 2000 to 3×10^4 , drag coefficient increases and attains a maximum value of 1.2 at Reynold's number, $Re = 3 \times 10^4$.
- When Reynold's number increases from 3×10^4 to 3×10^5 , the drag-coefficient decreases and at Reynolds number, $Re = 3 \times 10^5$, $C_D = 0.3$.
- If Reynolds number increases beyond 3×10^5 , drag coefficient C_D increases and becomes equal to 0.7.

4.10 Sol.

Friction factor,

$$f = \frac{64}{Re} \quad \text{for laminar flow}$$



5.1 Cavitation in a hydraulic reaction turbine is most likely to occur at the turbine

- (a) Entry (b) Exit
(c) Stator exit (d) Rotor exit

[1993 : 2 Marks]

5.2 Specific speed of a Kaplan turbine ranges between

- (a) 30 to 60 (b) 60 to 300
(c) 300 to 600 (d) 600 to 1000

[1993 : 2 Marks]

5.3 In terms of speed of rotation of the impeller N , discharge Q and change in total head H , through the machine, the specific speed for pump is (fill in the blanks)

[1994 : 1 Mark]

■■■■

Answers Turbines and Pumps

5.1 (d) 5.2 (d) 5.3 $(N_s = \frac{N\sqrt{Q}}{H^{3/4}})$

Explanations Turbines and Pumps

5.1 (d)

Cavitation phenomenon occurs due to the formation of localized low pressure area at rotor exit.

5.2 (d)

Classification of turbines based on value of specific speed:

Turbine	Specific speed (MKS unit)
Pelton turbine	10–35 (single jet)
Francis turbine	35–60 (multi jet)
Kaplan and propeller turbine	60–300
	300–1000

5.3 Sol.

Specific speed of pump,

$$N_s = \frac{N\sqrt{Q}}{H^{3/4}}$$

■■■■

Heat Transfer

UNIT VI

CONTENTS

1.	Conduction	44
2.	Free and Forced Convection	46
3.	Heat Transfer in Flow Over Plates and Pipes	47
4.	Radiation	48
5.	Heat Exchanger	50
6.	Fins and Unsteady Heat Transfer (Conduction and Convection)	51

- 1.1 Thermal conductivity is lower for
 (a) wood (b) air
 (c) water at 100°C (d) steam at 1 bar

[1990 : 1 Mark]

- 1.2 Match the property with their units

Property	Units
A. Bulk modulus	1. W/s
B. Thermal conductivity	2. N/m ²
C. Heat transfer coefficient	3. N/m ³
D. Heat flow rate	4. W
	5. W/mK
	6. W/m ² K

Codes:

- | | A | B | C | D |
|-----|---|---|---|---|
| (a) | 1 | 2 | 6 | 5 |
| (b) | 2 | 5 | 6 | 4 |
| (c) | 2 | 6 | 4 | 1 |
| (d) | 1 | 5 | 3 | 2 |

[1991 : 2 Marks]

- 1.3 For a current carrying wire of 20 mm diameter exposed to air ($h = 20 \text{ W/m}^2\text{K}$), maximum heat dissipation occurs when thickness of insulation (0.5 W/mK) is

- (a) 30 mm (b) 25 mm
 (c) 20 mm (d) 15 mm

[1993 : 2 Marks]

- 1.4 Two insulating material of thermal conductivity k and $2k$ are available for lagging a pipe carrying a hot fluid. If the radial thickness of each material is same

- (a) Material with higher thermal conductivity should be used for inner layer and one with lower thermal conductivity for the outer
 (b) Material with lower thermal conductivity should be used for inner layer and one with higher thermal conductivity for the outer
 (c) It is immaterial in which sequence the insulating material are used
 (d) It is not possible to judge unless numerical values of dimensions are given

[1994 : 1 Mark]



Answers Conduction

- 1.1 (b) 1.2 (b) 1.3 (d) 1.4 (b)

Explanations Conduction

1.1 (b)

Material	Thermal conductivity : k W/mK
Wood (wood fire)	0.11
Air (20°C)	0.025
Water (100°C)	0.6804
Steam (1 bar & 200°C)	0.03349

Note: Thermal conductivity of gases is lowest among all materials.

1.3 (d)

Given data:

$$d = 20 \text{ mm}$$

$$\therefore r = \frac{d}{2} = \frac{20}{2} = 10 \text{ mm}$$

$$h_o = 20 \text{ W/m}^2\text{K}$$

$$k = 0.5 \text{ W/mK}$$

For maximum heat dissipation,

Critical radius,

$$r_c = \frac{k}{h} \text{ for cylinder or wire}$$

$$= \frac{0.5}{20} = 0.025 \text{ m}$$

$$= 25 \text{ mm}$$

Thickness of insulation,

$$= r_c - r = 25 - 10$$

$$= 15 \text{ mm}$$

1.4 (b)

Method I:

Case-I: Lower thermal conductivity is used for inner layer.

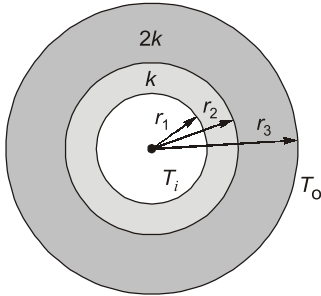

$$Q_1 = \frac{T_i - T_o}{R_{t1}}$$

where $R_{t1} = R_1 + R_2$

$$= \frac{1}{2\pi kl} \log_e \frac{r_2}{r_1} + \frac{1}{2\pi \times 2kl} \log_e \frac{r_3}{r_2}$$

$$= \frac{1}{4\pi kl} \left[2\log_e \frac{r_2}{r_1} + \log_e \frac{r_3}{r_2} \right]$$

$$= \frac{1}{4\pi kl} \left[\log_e \left(\frac{r_2}{r_1} \right)^2 + \log_e \frac{r_3}{r_2} \right] = \frac{1}{4\pi kl} \log_e \left(\frac{r_2 r_3}{r_1^2} \right)$$

Case-II: Higher thermal conductivity is used for inner layer

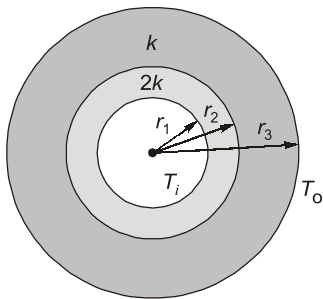

$$Q_2 = \frac{T_i - T_o}{R_{t2}}$$

where $R_{t2} = R_1 + R_2$

$$= \frac{1}{2\pi \times 2kl} \log_e \frac{r_2}{r_1} + \frac{1}{2\pi kl} \log_e \frac{r_3}{r_2}$$

$$= \frac{1}{4\pi kl} \left[\log_e \frac{r_2}{r_1} + 2\log_e \frac{r_3}{r_2} \right]$$

$$= \frac{1}{4\pi kl} \left[\log_e \frac{r_2}{r_1} + \log_e \left(\frac{r_3}{r_2} \right)^2 \right] = \frac{1}{4\pi kl} \log_e \left(\frac{r_3^2}{r_1 r_2} \right)$$

Hence $R_{t1} > R_{t2}$ because

$$\log_e \left(\frac{r_2 r_3}{r_1^2} \right) > \log_e \left(\frac{r_3^2}{r_1 r_2} \right)$$

So, low heat transfer when material with lower thermal conductivity should be used for inner layer and one with higher thermal conductivity for the outer.

Remember: Higher thermal resistance (or lower thermal conductivity) is used for inner layer for minimum heat transfer.



2

Free and Forced Convection

- 2.1 In pool boiling the highest HTC occurs in
- (a) Subcooled boiling zone
 - (b) Nucleate boiling zone
 - (c) Partial film boiling zone
 - (d) Film boiling zone

[1990 : 1 Mark]



Answers Free and Forced Convection

- 2.1 (b)

3

Heat Transfer in Flow Over Plates and Pipes

- 3.1** For the fluid flowing over a flat plate with Prandtl number greater than unity, the thermal boundary layer for laminar forced convection.
- is thinner than the hydrodynamic boundary layer
 - has thickness equal to zero
 - is of same thickness as hydrodynamic boundary layer
 - is thicker than the hydrodynamic boundary layer
- [1988 : 1 Mark]**
- 3.2** A fluid flowing over a flat plate has the following properties : dynamic viscosity = 25×10^{-6} kg/ms, specific heat = 2.0 kJ/kgK, thermal conductivity 0.05 W/mK. The hydrodynamic boundary layer thickness is measured to be 0.5 mm. The thickness of the thermal boundary layer would be
- 0.1 mm
 - 0.5 mm
 - 1.0 mm
 - None of these
- [1992 : 2 Marks]**
- 3.3** For air near atmospheric condition flowing over a flat plate the laminar thermal boundary layer is thicker than hydrodynamic boundary layer (T/F).
- [1994 : 1 Mark]**

■■■■

Answers Heat Transfer in Flow Over Plates and Pipes

3.1 (a) 3.2 (b) 3.3 (True)

Explanations Heat Transfer in Flow Over Plates and Pipes

3.1 (a)

$$Pr^{1/3} = \frac{\delta}{\delta_t}, \text{ if } Pr > 1, \text{ it means } \delta > \delta_t.$$

3.2 (b)

$$Pr = \frac{\mu C_p}{k_f} = \frac{25 \times 10^{-6} \times 2 \times 10^3}{0.05} = 1$$

$$\Rightarrow \frac{\delta}{\delta_t} = 1$$

Now $\delta = 0.5 \text{ mm}$

Therefore $\delta = \delta_t = 0.5 \text{ mm}$

3.3 Sol. True

$$\text{For Air } Pr = 0.69 \Rightarrow \nu < \alpha$$

$$\delta < \delta_t$$

■■■■

4.1 For a glass plate transmissivity and reflectivity are specified as 0.86 and 0.08 respectively, the absorptivity of the glass plate is

- (a) 0.86 (b) 0.08
 (c) 1.00 (d) 0.06 [1988 : 1 Mark]

4.2 A diffuse radiation surface has

- (a) Radiation intensity independent of angle
 (b) Emissive power independent of angle
 (c) Emissive power independent of wavelength
 (d) Radiation intensity independent of both angle and wavelength [1991 : 1 Mark]

4.3 The radiative heat transfer rate per unit area (W/m^2) between two plane parallel gray surfaces (emissivity = 0.9) maintained at 400 K and 300 K is (σ_p = Stefan Boltzmann constant = $5.67 \times 10^{-8} W/m^2K^4$)

- (a) 992 (b) 812
 (c) 464 (d) 567 [1993 : 2 Marks]

4.4 The shape factors with themselves of two infinitely long black body concentric cylinders with a dia ratio of 3 are ... for the inner and for the outer

[1994 : 1 Mark]



Answers Radiation

4.1 (d) 4.2 (a) 4.3 (b) 4.4 (2/3)

Explanations Radiation

4.1 (d)

Transmissivity: $\tau = 0.86$

Reflectivity: $\rho = 0.08$

Absorptivity: $\alpha = ?$

For any surface,

$$\alpha + \tau + \rho = 1$$

$$\alpha + 0.86 + 0.08 = 1$$

$$\alpha = 0.06$$

4.2 (a)

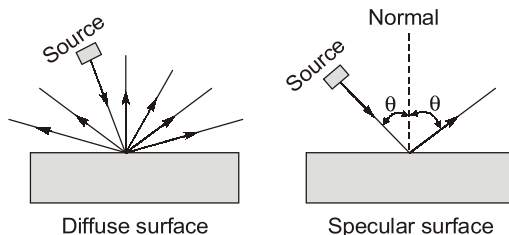

4.3 (b)

For plane surfaces,

$$\frac{Q}{A} = \frac{\sigma(T_1^4 - T_2^4)}{\frac{1}{\epsilon_1} + \frac{1}{\epsilon_2} - 1}$$

Here, $\epsilon_1 = \epsilon_2 = 0.9$

$$\frac{Q}{A} = \frac{5.67 \times 10^{-8} (400^4 - 300^4)}{\frac{1}{0.9} + \frac{1}{0.9} - 1}$$

$$= 811.84 W/m^2 \approx 812 W/m^2$$

4.4 Sol.

$$\frac{d_2}{d_1} = 3$$

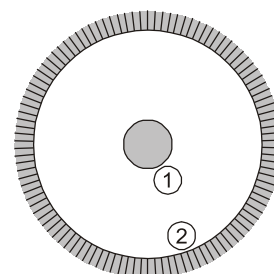

For body-1, $F_{11} = 0$

$$F_{11} + F_{12} = 1$$

$$F_{12} = 1$$

For body-2

$$F_{21} + F_{22} = 1 \quad \dots(i)$$

Applying reciprocity theorem

$$A_1 F_{12} = A_2 F_{21}$$

$$A_1 = A_2 F_{21}$$

or
$$F_{21} = \frac{A_1}{A_2} = \frac{\pi d_1 l}{\pi d_2 l} = \frac{d_1}{d_2} = \frac{1}{3}$$

$$F_{21} = \frac{1}{3}$$

Substituting $F_{21} = \frac{1}{3}$ in Eq. (i), we get

$$\frac{1}{3} + F_{22} = 1$$

or
$$F_{22} = 1 - \frac{1}{3} = \frac{2}{3}$$



5.1 In shell and tube heat exchanger, baffles are mainly used to

- (a) increase the mixing of fluid
- (b) increase the heat transfer area
- (c) deflect the flow in desired direction
- (d) reduce fouling of the tube surface

[1991 : 1 Mark]

5.2 The practice to use steam on the shell side and water on the tube side in condensers of steam power plant is because

- (a) to increase overall HT coefficient, water side velocity can be increased if water is on the tube side
- (b) condenser can act as a storage unit for condensed steam
- (c) rate of condensation of steam is invariably smaller than the mass flow rate of cooling water
- (d) it is easier to maintain vacuum on the shell side than on the tube side

[1994 : 1 Mark]

■■■■

Answers Heat Exchanger

5.1 (c) 5.2 (d)

Explanations Heat Exchanger

5.1 (c)

Baffles are mainly used to deflect the flow in desired direction.

5.2 (d)

If the steam is maintained on the shell side whatever the vacuum obtained due to condensation of steam are rather because of change in specific volume of steam due to condensation can be easily maintained i.e. air leaked into the condensor can be easily extracted.

■■■■

6

Fins and Unsteady Heat Transfer (Conduction and Convection)

6.1 The heat transfer process between body and its ambient is governed by an Internal Conductive Resistance (ICR) and an External Convective Resistance (ECR). The body can be considered to be a lumped heat capacity system is

- (a) $ICR > ECR$
- (b) ICR is marginally smaller than ECR
- (c) $ICR = ECR$
- (d) ICR is negligible

[1989 : 1 Mark]

6.2 Biot number signifies

- (a) The ratio of heat conducted to heat convected
- (b) The ratio of heat convected to heat conducted
- (c) The ratio of external convective resistance to internal conductive resistance
- (d) The ratio of internal conductive resistance to external convective resistance

[1991 : 1 Mark]

6.3 Two rods, one of length L and the other of length $2L$ are made of the same material and have the same diameter. The two ends of the longer rod are maintained at 100°C . One end of the shorter rod is maintained at 100°C while the other end is insulated. Both the rods are exposed to the same environment at 40°C . The temp at the insulated end of the shorter rod is measured to be 55°C . The temp at the mid point of the longer rod would be.

- (a) 40°C
- (b) 50°C
- (c) 55°C
- (d) 100°C

[1992 : 2 Marks]

6.4 When the fluid velocity is doubled the thermal time constant of a thermometer used of measuring the fluid temperature reduces by a factor of 2 (T/F)

[1994 : 1 Mark]



Answers Fins and Unsteady Heat Transfer (Conduction and Convection)

6.1 (d) 6.2 (d) 6.3 (c) 6.4 (False)

Explanations Fins and Unsteady Heat Transfer (Conduction and Convection)

6.1 (d)

Lumped heat capacity is applicable when $Bi < 0.1$

$$Bi = \frac{hl}{k} = \frac{l/kA}{1/hA} = \frac{ICR}{ECR}$$

For desired condition *i.e.*, $Bi < 0.1$ k should be greater than h .

Therefore ICR should be very small

6.2 (d)

Biot number,

$$Bi = \frac{hl}{k} = \frac{hA}{kA} = \frac{l/kA}{1/hA} = \frac{R_{\text{cond}}}{R_{\text{conv}}}$$

6.3 (c)

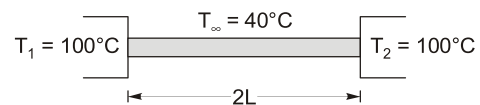

Temperature distribution along the rod is given by

$$\theta = T - T_\infty$$

$$\theta = \frac{\theta_1 \sinh m(l-x) + \theta_2 \sinh mx}{\sinh ml}$$

where
and

$$x = L; \quad l = 2L$$

$$\theta_1 = 100 - 40 = 60^\circ\text{C}$$

$$\theta_2 = 100 - 40 = 60^\circ\text{C}$$

i.e.,

$$\theta_1 = \theta_2$$

$$\theta = \frac{\theta_1 [\sinh ml + \sinh ml]}{\sinh 2ml}$$

$$\theta = \theta_1 \frac{2 \sinh ml}{\sinh 2ml} \quad \dots(i)$$

For rod of length l with insulated tip temperature distribution

$$\theta = \theta_0 \frac{\cosh[m(l-x)]}{\cosh ml}$$

for $x = L$

$$\theta_L = \theta_0 \frac{1}{\cosh ml}$$

$$\cosh ml = \frac{\theta_0}{\theta_L} = \frac{100 - 40}{50 - 40} = \frac{60}{15} = 4$$

$$ml = (\cosh^{-1} 4) = 2.063 \quad \dots(ii)$$

For same material fins

By Eqs. (i) and (ii), we get

$$\theta_{l/2} = 60 \times \frac{2 \sinh 2.063}{\sinh 4.126}$$

$$T_{l/2} - T_\infty = 15$$

$$T_{l/2} = 55^\circ\text{C}$$

6.4 False

Explanation: When the velocity of the fluid gets doubled across a thermometer it is not necessary that the convective heat transfer coefficient “ h ” decreases by half.

$$\text{Time constant} = \frac{\rho V C_p}{hA}$$



Thermodynamics

UNIT

VII

CONTENTS

- | | | |
|----|--|----|
| 1. | Thermodynamic System and Processes | 54 |
| 2. | First Law of Thermodynamics, Heat,
Work and Energy Interactions | 55 |
| 3. | Second Law of Thermodynamics,
Carnot Cycle and Entropy | 57 |
| 4. | Properties of Pure Substances | 59 |

- 1.1 The definition of 1 K as per the internationally accepted temperature scale is
- (a) $1/100^{\text{th}}$ the difference between normal boiling point and normal freezing point of water
 - (b) $1/273.15^{\text{th}}$ the normal freezing point of water
 - (c) 100 times the difference between the triple point of water and the normal freezing point of water
 - (d) $1/273.16^{\text{th}}$ of the triple point of water

[1994 : 1 Mark]

■ ■ ■ ■

Answers Thermodynamic System and Processes

1.1 (d)

Explanations Thermodynamic System and Processes

1.1 (d)

The kelvin (abbreviation K), is the standard international (SI) unit of thermodynamic temperature. One kelvin (1 K) is formally defined as $1/273.16^{\text{th}}$ of triple point of water.

■ ■ ■ ■

2

First Law of Thermodynamics, Heat, Work & Energy Interactions

- 2.1 An insulated rigid vessel contains a mixture of fuel and air. The mixture is ignited by a minute spark. The contents of the vessel experience
- Increase in temperature, pressure and energy
 - Decrease in temperature, pressure and energy
 - Increase in temperature and pressure but no change in energy
 - Increase in temperature and pressure but decrease in energy

[1993 : 1 Mark]

- 2.2 The first law of thermodynamics takes the form $W = -\Delta H$ when applied to
- A closed system undergoing a reversible adiabatic process
 - An open system undergoing an adiabatic process with negligible changes in kinetic and potential energies
 - A closed system undergoing a reversible constant volume process
 - A closed system undergoing a reversible constant pressure process.

[1993 : 1 Mark]

- 2.3 A steel ball of mass 1 kg of specific heat 0.4 kJ/kgK is at a temperature of 60°C. It is dropped into 1 kg water at 20°C. The final steady state temperature of water is
- 23.5°C
 - 30°C
 - 35°C
 - 40°C [1993 : 1 Mark]

- 2.4 A vertical cylinder with a freely floating piston contains 0.1 kg air at 1.2 bar and a small electrical resistor. The resistor is wired to an external 12 Volt battery. When a current of 1.5 amps is passed through the resistor for 90 seconds, the piston sweeps a volume of 0.01 m³. Assume (i) piston and the cylinder are insulated and (ii) air behaves as an ideal gas with $c_v = 700$ J/kgK. Find the rise in temperature of air.

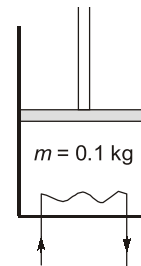

[1993 : 2 Marks]

■■■■

Answers First Law, Heat, Work and Energy

- 2.1 (c) 2.2 (b) 2.3 (a) 2.4 (6)

Explanations First Law, Heat, Work and Energy

2.1 (c)

When the mixture is ignited by a minute spark, it will result in combustion of fuel, due to which:

- Increase in temperature
- As it is rigid vessel, so volume will be constant, then pressure will increase.
- Also, as it is an insulated vessel, so $\delta Q = 0$. hence energy generated due to the combustion will increase the sensible energy and decrease the chemical energy but the total internal energy will remain constant, it means no change in energy.

2.2 (b)

The first law of thermodynamics takes the form $W = -\Delta H$ when applied to an open system undergoing an adiabatic process with negligible changes in kinetic and potential energies.

$$\begin{aligned}
 H_1 + \frac{1}{2}mC_1^2 + mgz_1 + Q \\
 &= H_2 + \frac{1}{2}mC_2^2 + mgz_2 + W \\
 H_1 &= H_2 + W \\
 -(H_2 - H_1) &= W \\
 W &= -\Delta H
 \end{aligned}$$

2.3 (a)**Given data:**

Mass of steel ball,

$$m_s = 1 \text{ kg}$$

Specific heat of steel ball,

$$c_s = 0.4 \text{ kJ/kgK}$$

Initial temperature of ball,

$$T_1 = 60^\circ\text{C}$$

Mass of water,

$$m_w = 1 \text{ kg}$$

Initial temperature of water,

$$T_{w1} = 20^\circ\text{C}$$

Let T_f = Final temperature of ball and water

Applying energy balance equation,

Heat lost by a steel ball

$$= \text{Heat gained by the water}$$

$$m_s c_s (T_1 - T_f) = m_w c_w (T_f - T_{w1})$$

$$1 \times 0.4 (60 - T_f) = 1 \times 4.18 (T_f - 20)$$

$$24 - 0.4 T_f = 4.18 T_f - 83.6$$

$$\text{or } 107.6 = 4.58 T_f$$

$$\text{or } T_f = 23.49^\circ\text{C} \approx \mathbf{23.50^\circ\text{C}}$$

2.4 Sol.**Given:** $m = 0.1 \text{ kg}$, $E = 12 \text{ volt}$, $t = 90 \text{ s}$, $\Delta V = 0.01 \text{ m}^3$, $P = 1.2 \text{ bar}$, $I = 1.5 \text{ amps}$.

Assumption:

I. Piston and cylinder are insulated, i.e. $\delta Q = 0$

II. Air behaves as an ideal gas with

$$c_v = 700 \text{ J/kgK}$$

 \therefore Electric work done on air,

$$\delta W_e = EIt = 12 \times 1.5 \times 90 = 1620 \text{ J}$$

 \therefore Work done by air,

$$\delta W_{\text{air}} = p dV = 1.2 \times 10^5 \times 0.01 = 1200 \text{ J}$$

(As there is freely floating piston, so pressure will remain constant)

Now, from 1st law of thermodynamics,

$$\delta Q = dU + (\delta W)_{\text{total}}$$

$$0 = mc_v dT + \delta W_{\text{air}} - \delta W_e$$

$$0 = 0.1 \times 700 \times dT + 1200 - 1620$$

$$dT = \frac{420}{70} = 6^\circ\text{C}$$

**POINTS TO REMEMBER**

- (i) Here electric work is done on system, so it will be negative.
- (ii) Work done by air, will be positive.



3

Second Law of Thermodynamics, Carnot Cycle and Entropy

3.1 A condenser of a refrigeration system rejects heat at a rate of 120 kW, while its compressor consumes a power of 30 kW. The coefficient of performance of the system would be

- (a) 1/4 (b) 4
(c) 1/3 (d) 3 [1992 : 1 Mark]

3.2 A reversible heat transfer demands:

- (a) The temperature difference causing heat transfer tends to zero
(b) The system receiving heat must be at a constant temperature
(c) The system transferring out heat must be at a constant temperature
(d) Both interacting systems must be at constant temperatures

[1993 : 1 Mark]

3.3 Which among the following relations is/are valid only for reversible process undergone by a pure substance?

- (a) $\delta Q = dU + \delta W$
(b) $TdS = dU + \delta W$
(c) $TdS = dU + PdV$
(d) $\delta Q = PdV + dU$

[1993 : 1 Mark]

3.4 Figure below shows a reversible heat engine E_R having heat interactions with three constant temperature systems. Calculate the thermal efficiency of the heat engine

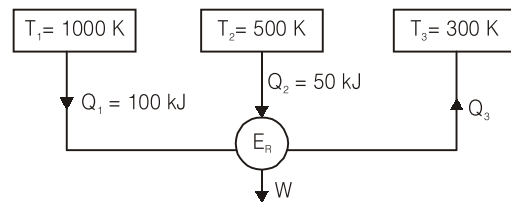

[1993 : 2 Marks]

3.5 When a system executes an irreversible cycle

- (a) $\oint \frac{\delta Q}{T} < 0$ (b) $\oint dS > 0$
(c) $\oint \frac{dQ}{T} = 0$ (d) $\oint \frac{\delta Q}{T} > 0$

[1994 : 1 Mark]

3.6 The slopes of constant volume and constant pressure lines in the T - s diagram are..... and respectively.

[1994 : 1 Mark]

3.7 A 1500 W electrical heater is used to heat 20 kg of water ($c_p = 4186 \text{ J/kgK}$) in an insulated bucket, from a temperature of 30°C to 80°C . If the heater temperature is only infinitesimally larger than the water temperature during the process, the change in entropy for the heater is..... J/K and for water J/K.

[1994 : 1 Mark]

3.8 Any thermodynamic cycle operating between two temperature limits is reversible if the product of the efficiency when operating as a heat engine and the COP when operating as a refrigerator is equal to 1.

[TRUE/FALSE]
[1994 : 1 Mark]

■■■■

Answers Second Law, Carnot Cycle and Entropy

3.1 (d) 3.2 (a) 3.3 (d) 3.4 (60) 3.5 (a) 3.6 ($\frac{T}{c_v}$ and $\frac{T}{c_p}$)

3.7 (*,+12786.99) 3.8 (False)

Explanations Second Law, Carnot Cycle and Entropy

3.1 (d)

$$Q_1 = 120 \text{ kW}$$

$$W = 30 \text{ kW}$$

$$\text{also } W = Q_1 - Q_2$$

$$\therefore 30 = 120 - Q_2$$

$$\text{or } Q_2 = 120 - 30 = 90 \text{ kW}$$

Coefficient of performance,

$$(\text{COP})_R = \frac{Q_2}{W} = \frac{90}{30} = 3$$

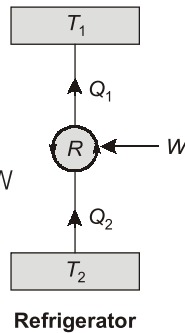

3.2 (a)

For reversible heat transfer, entropy change of universe must be zero.

$$\begin{aligned} (\Delta S)_{uni} &= (\Delta S)_{system} + (\Delta S)_{surr} = 0 \\ &= \left(\frac{\delta Q}{T_1} \right)_{system} - \left(\frac{\delta Q}{T_2} \right)_{surr}. \end{aligned}$$

So, for this condition, T_1 should be equal to T_2 . So for the reversible heat transfer, the temperature difference causing the heat transfer tends to zero.

3.3 (d)

As we know according to I-law of thermodynamics,

$$\delta Q = dU + \delta W$$

Conditions for applying the equation,

$$\delta W = \int P dV \text{ are:}$$

- the system must be a closed system.
- Work should cross the boundary.
- the process must be a reversible process.

$$\text{So, } \delta Q = dU + P dV$$

3.4 Sol.

For reversible cycle,

$$\oint \frac{\delta Q}{T} = 0$$

$$\frac{100}{1000} + \frac{50}{500} - \frac{Q_3}{300} = 0$$

$$0.2 - \frac{Q_3}{300} = 0$$

$$\text{or } Q_3 = 60 \text{ kJ}$$

Now,

$$Q_1 + Q_2 = W + Q_3$$

$$100 + 50 = W + 60$$

$$W = 90 \text{ kJ}$$

$$\eta = \frac{W}{Q_{\text{added}}} = \frac{90}{150} = 0.6 = 60\%$$

3.5 (a)

Inequality of clausius: It provides the criteria of irreversibility of cycle.

$$\oint \frac{dQ}{T} \leq 0$$

If $\oint \frac{dQ}{T} = 0$, the cycle is reversible

If $\oint \frac{dQ}{T} < 0$, the cycle is irreversible and possible.

If $\oint \frac{dQ}{T} > 0$, the cycle is impossible.

3.6 Sol.

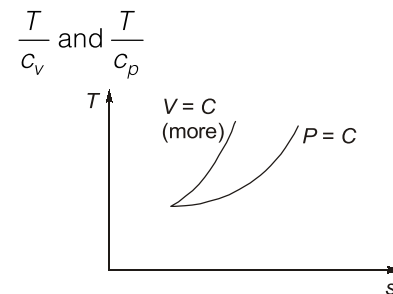

$$\left(\frac{\partial T}{\partial S} \right)_v = \frac{T}{c_v} \text{ and } \left(\frac{\partial T}{\partial S} \right)_p = \frac{T}{c_p}$$

Slope of constant volume line = γ (slope of constant pressure lines). So slope of constant volume lines on T - s diagram is higher than the slope of constant pressure lines.

3.7 Sol.

Entropy change for water,

$$\begin{aligned} \Delta S_w &= m_w c_p \ln \left(\frac{T_2}{T_1} \right) \quad (\because \text{incompressible}) \\ &= 20 \times 4186 \ln \left(\frac{80 + 273}{30 + 273} \right) \\ &= 12786.99 \text{ J/K} \end{aligned}$$

In the absence of mass and specific heat of heater we cannot find entropy change of heater.

3.8 Sol. False

$$\eta_E = 1 - \frac{T_L}{T_H}, (\text{COP})_R = \frac{T_L}{T_H - T_L}$$

$$\eta_E \times (\text{COP})_R = \frac{T_H - T_L}{T_H} \times \frac{T_L}{T_H - T_L} = \frac{T_L}{T_H}$$

T_L and T_H are two different temperatures.

4

Properties of Pure Substances

4.1 The relationship $(\partial T/\partial P)_h = 0$ holds good for

- An ideal gas at any state
- A real gas at any state
- Any gas at its critical state
- Any gas at its inversion point

[1993 : 1 Mark]

4.2 During the phase change of a pure substance

- $dG = 0$
- $dP = 0$
- $dH = 0$
- $dU = 0$

[1993 : 1 Mark]

4.3 At the triple point of a pure substance, the number of degrees of freedom is

- 0
- 1
- 2
- 3

[1993 : 1 Mark]

4.4 A vessel of volume 1.0 m^3 contains a mixture of liquid water and steam in equilibrium at 1.0 bar . Given that 90% of the volume is occupied by the steam, find the fraction of the mixture. Assume at 1.0 bar , $v_f = 0.001 \text{ m}^3/\text{kg}$ and $v_g = 1.7 \text{ m}^3/\text{kg}$.

[1993 : 2 Marks]

4.5 In the vicinity of the triple point, the vapour pressures of liquid and solid ammonia are respectively given by

$$\ln P = 15.16 - 3063/T$$

$$\ln P = 18.70 - 3754/T$$

where P is in atmospheric and T is in kelvin.

What is the temperature at the triple point?

[1993 : 2 Marks]



Answers Properties of Pure Substances

4.1 (a, d) 4.2 (a, b) 4.3 (a) 4.4 (5.262×10^{-3}) 4.5 (195.2)

Explanations Properties of Pure Substances

4.1 (a, d)

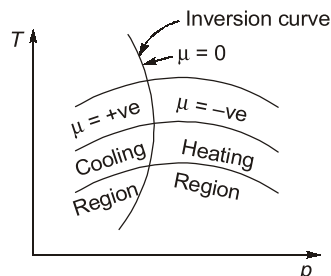

Fig: General substance

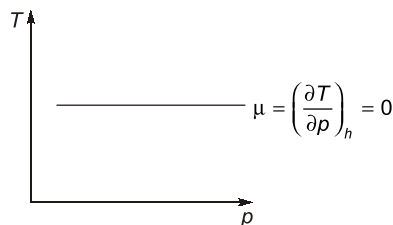

Fig: Ideal gas



POINTS TO REMEMBER

- Joule-Thomson coefficient (μ) is zero everywhere on the inversion curve.
- For ideal gas, ($\mu = 0$) at any state.

4.2 (b)

During phase change of a substance,

$$dT = 0$$

$$dP = 0$$

4.3 (a)

Gibb's phase rule:

$$F + P = C + 2$$

where, F = degree of freedom, P = no. of phases
 C = no. of components

For pure substance, no. of components, $C = 1$

At triple point, no. of phases, $P = 3$

$$\therefore F + 3 = 1 + 2$$

Degree of freedom, $F = 0$



POINTS TO REMEMBER

- On P - T diagram, triple point and critical point both are points.
- On P - V diagram, triple point is a line and critical point is a point.

4.4 Sol.**Method I:**

Volume of the mixture,

$$V = 1 \text{ m}^3$$

Pressure: $p = 1 \text{ bar}$

Volume of steam,

$$\begin{aligned} V_g &= 90\% \text{ of } V \\ &= 0.9 V = 0.9 \times 1 = 0.9 \text{ m}^3 \end{aligned}$$

∴ Volume of liquid water,

$$V_f = V - V_g = 1 - 0.9 = 0.1 \text{ m}^3$$

$$v_f = 0.001 \text{ m}^3/\text{kg}$$

$$v_g = 1.7 \text{ m}^3/\text{kg}$$

Specific volume of liquid water,

$$v_f = \frac{V_f}{m_f}$$

$$0.001 = \frac{0.1}{m_f} \text{ or } m_f = 100 \text{ kg}$$

Specific volume of steam,

$$v_g = \frac{V_g}{m_g}$$

$$1.7 = \frac{0.9}{m_g}$$

or $m_g = 0.529 \text{ kg}$

Dryness fraction,

$$\begin{aligned} x &= \frac{m_g}{m_f + m_g} = \frac{0.529}{100 + 0.529} \\ &= 5.262 \times 10^{-3} \end{aligned}$$

Method II:

Mass of mixture in the vessel,

$$\begin{aligned} m &= m_f + m_g \\ &= \frac{V_f}{v_f} + \frac{V_g}{v_g} \\ &= \frac{0.1}{0.001} + \frac{0.9}{1.7} = 100.53 \text{ kg} \end{aligned}$$

Specific volume of mixture,

$$\begin{aligned} v &= \frac{1}{m} = \frac{1}{100.53} \\ &= 9.947 \times 10^{-3} \text{ m}^3/\text{kg} \end{aligned}$$

Also,

$$v = v_f + x(v_g - v_f) \quad (x = \text{dryness fraction})$$

$$x = \frac{v - v_f}{v_g - v_f} = \frac{0.009947 - 0.001}{1.7 - 0.001}$$

Dryness fraction,

$$x = 5.266 \times 10^{-3}$$

4.5 Sol.

At triple point all the three phases exist in equilibrium

∴ Triple point pressure of liquid and solid ammonia is same

$$\therefore 15.16 - \frac{3063}{T} = 18.70 - \frac{3754}{T}$$

$$(15.16)T - 3063 = (18.70)T - 3754$$

$$(3.54)T = 691$$

or $T = 195.2 \text{ K}$



Power Plant Engineering

UNIT VIII

CONTENTS

1.	Compressible Flow	62
2.	Steam Power Cycles & Steam Turbines	63
3.	Gas Turbines	66
4.	Miscellaneous	68

1.1 Subsonic and supersonic diffusers have the following geometry.

- (a) Divergent and convergent respectively
- (b) Both divergent
- (c) Both convergent
- (d) Convergent and divergent respectively

[1992 : 2 Marks]



Answers Compressible Flow

1.1 (a)

Explanations Compressible Flow

1.1 (a)

For subsonic compressible flow, converging passage works as nozzle and diverging passage acts as a diffuser.

for supersonic compressible flow, converging passage works as diffuser while diverging passages works as nozzle.



POINTS TO REMEMBER

- When Mach number $M = 1$, Maximum discharge possible (i.e. choked condition)
- When Mach number, $M = 1$, Sonic flow always occur at a place where $dA = 0$. Hence supersonic velocity can't be achieved by convergent only or divergent only. Hence convergent divergent is designed.



- 2.1 An economizer in a steam generator performs the function of
- Preheating the combustion air
 - Preheating the feed water
 - Preheating the input fuel
 - Raising the temperature of steam
- [1989 : 2 Marks]
- 2.2 The fundamental objective of employing the condenser in a steam power plant is to (reduce/increase) the dryness fraction of steam.
- [1989 : 2 Marks]
- 2.3 The current level of the maximum temperature of steam turbine inlet is much lower than that at gas turbine inlet because
- The fuel combustion temperature in a steam generator is lower than that in a gas turbine engine
 - Of the corrosive nature of high temperature steam on super heater tubes
 - The materials used for the gas turbine blades are not suitable for the steam turbine blades
 - Unlike the gas turbine blades the steam turbine blades cannot be cooled
- [1989 : 2 Marks]
- 2.4 In the Rankine cycle when superheated steam is used
- Thermal efficiency increases
 - Steam consumption decreases
 - Steam dryness after expansion increases
 - All of the above
- [1990 : 2 Marks]
- 2.5 When initially dry and saturated steam flows through a nozzle, the ratio of actual discharge to calculated discharge is
- Equal to 1.0
 - Greater than 1.0
 - Less than 1.0
 - Independent of inlet conditions
- [1990 : 2 Marks]
- 2.6 In a Rankine cycle heat is added
- Reversibly at constant volume
 - Reversibly at constant temperature
 - Reversibly at constant pressure and temperature
 - Reversibly at constant pressure
- [1991 : 2 Marks]
- 2.7 Velocity compounded steam turbine known as (Curtis/Rateau) turbine uses the principle of converting entire (pressure/velocity) energy before entering the first stage runner itself.
- [1991 : 2 Marks]
- 2.8 A steam turbine operating with less moisture is (more/less) efficiency and (less/more) prone to blade damage.
- [1992 : 2 Marks]
- 2.9 The equivalent evaporation (kg/hr) of a boiler producing 2000 kg/hr of steam with enthalpy content of 2426 kJ/kg from feed water at temperature 40°C (liquid enthalpy = 168 kJ/kg) is (enthalpy of vaporization of water at 100°C = 2258 kJ/kg)
- 2000
 - 2149
 - 186
 - 1649
- [1993 : 2 Marks]
- 2.10 For a given set of operating pressure limits of a Rankine cycle the highest efficiency occurs for
- Saturated cycle
 - Superheated cycle
 - Reheat cycle
 - Regenerative cycle
- [1994 : 1 Mark]
- 2.11 For a single stage impulse turbine with rotor diameter of 2 m and a speed of 3000 rpm when the nozzle angle is 20°, the optimum velocity of steam in m/s is
- 334
 - 356
 - 668
 - 711
- [1994 : 1 Mark]

Answers Steam Power Cycles & Steam Turbines

- 2.1 (b) 2.2 (b) 2.3 (b) 2.4 (d) 2.5 (b) 2.6 (d)
 2.7 (Curtis, pressure) 2.8 (more, less) 2.9 (a) 2.10 (d) 2.11 (c)

Explanations Steam Power Cycles & Steam Turbines**2.1 (b)**

An economizer is a heat exchanger used for heating the feed water before it enters the boilers. The economizer recovers some of waste heat of hot flue gases going to the chimney and thus it helps in improving the boiler efficiency. Economizer is placed in the path of flue gases at the rear end of the boiler just before the air preheater.

2.2 Sol.**Reduces**

In a steam power plant, condenser plays a very important role. The main functions of a steam condenser are given below:

- The condenser lowers the back pressure at the turbine exhaust and because of that, steam expands through a higher pressure ratio across the turbine. It results into.
 - reduced consumption of steam
 - increased work done per cycle
 - improved thermal efficiency of the cycle.
- The condenser enables the recovery and recirculation of pure feed water into the plant.
- Condenser **reduces** the dryness fraction of steam.
- The condenser enables the removal of non-condensable gases and air from steam and thus the heat transfer rate is improved and tube corrosion is reduced.

2.3 (b)

The current level of the maximum temperature of steam turbine inlet is much lower than that of gas turbine inlet because of the corrosive nature of high temperature steam on super heater tubes.

2.4 (d)

In the Rankine cycle, when superheated steam is used:

- Thermal efficiency increases
- Steam consumption decreases

- Steam dryness after expansion increases
- Heat input and heat rejection increases

2.5 (b)

When initially dry and saturated steam flows through a nozzle, the ratio of actual discharge to calculated discharge is greater than 1.0 because it is a case of super saturated flow condition due to which

- mass flow rate increases
- specific volume reduces
- enthalpy drop decreases
- exit velocity decreases
- entropy increases

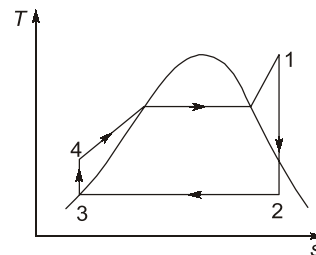
2.6 (d)

Process 4–1: Indicates isobaric heating of feed water, its change of phase from liquid to vapour and then its superheating in the boiler due to the heat transfer from the hot combustion flue gases to the feed water.

The state of the steam leaving the boiler is high pressure, high temperature, super heated steam.

2.7 Sol.**Curtis, pressure**

Simple impulse turbine – De laval turbine

Pressure compounded turbine – Rateau turbine

Velocity compounded turbine – **Curtis** turbine

50% reaction turbine – Parson's turbine

100% reaction turbine – Hero's turbine

In the velocity compounded turbine, whole **pressure** converts to velocity in the nozzle before entering rotor and compounding is done for velocity of steam.

2.8 Sol.

more, less

A steam turbine which operates with less moisture always have **more** efficiency and due to the decrease in moisture, turbine is **less** prone to blade damage.

2.9 (a)

Given data:

Rate of steam producing, $m_s = 2000$ kg/hr

Specific enthalpy steam, $h = 2426$ kJ/kg

Specific enthalpy of feed water,

$$h_f = 168 \text{ kJ/kg}$$

Enthalpy of vaporization of water,

$$h_{fg} = 2258 \text{ kJ/kg}$$

we know that,

Equivalent evaporation,

$$\begin{aligned} m_e &= \frac{\text{Total heat required to evaporated feed water}}{\text{Latent heat of steam at } 100^\circ\text{C}} \\ &= \frac{m_s(h - h_f)}{h_{fg}} = \frac{2000(2426 - 168)}{2258} \\ &= 2000 \text{ kg/hr} \end{aligned}$$

2.10 (d)

The thermal efficiency of an ideal regenerative cycle is equal to the Carnot efficiency.

i.e., $\eta_{\text{regenerative}} = \eta_{\text{Carnot}}$

Hence, it is maximum.

2.11 (c)

Blade velocity,

$$\begin{aligned} u &= \frac{\pi DN}{60} = \frac{3.14 \times 2 \times 3000}{60} \\ &= 314 \text{ m/s} \end{aligned}$$

Optimum velocity ratio,

$$= \frac{u}{v_1} = \frac{\cos 2}{2}$$

Optimum velocity of steam

$$\begin{aligned} v_1 &= \frac{2u}{\cos \alpha} \\ &= \frac{2 \times 314}{\cos 20^\circ} = 668.3 \text{ m/s} \end{aligned}$$

**POINTS TO REMEMBER**

In reaction turbine, optimum velocity ratio,

$$\left(\frac{u}{v_1} \right) = \cos \alpha$$

where, α = Nozzle angle.



3.1 In a gas turbine power plant intercooler are used to cool the (hot gases/compressed air) in order to decrease the (expansion work/compression work)

[1989 : 2 Marks]

3.2 Air expands steadily through a turbine from 6 bar, 800 K to 1 bar, 520 K. During the expansion, heat transfer from air to the surroundings at 300 K is 10 kJ/kg air. Neglect the changes in kinetic and potential energies and evaluate the irreversibility per kg air. Assume air to behave as an ideal gas with $c_p = 1.0$ kJ/kgK and $R = 0.3$ kJ/kgK.

[1993 : 2 Marks]

3.3 In problem 6.14 find the actual work and maximum work per kg air.

[1993 : 2 Marks]

3.4 A gas turbine cycle with heat exchanger and reheating improves

- (a) Only the thermal efficiency
- (b) Only the specific power output
- (c) Both thermal efficiency and specific power output
- (d) Neither thermal efficiency nor specific power output

[1993 : 2 Marks]

3.5 A gas turbine cycle with infinitely large number of stages during compression and expansion leads to

- (a) Stirling cycle
- (b) Atkinson cycle
- (c) Ericsson cycle
- (d) Brayton cycle

[1994 : 1 Mark]

■■■■

Answers Gas Turbines

3.1 (Compressed air, Compression work) **3.2** (42.03) **3.3** (270 & 312.04) **3.4** (c) **3.5** (c)

Explanations Gas Turbines

3.1 Sol.

Compressed air, Compression work

In a gas turbine power plant, intercooler are used to cool the compressed air and due to this compression work is reduced and more air mass can be supplied to turbine.

3.2 Sol.

Given data:

At inlet,

$$p_1 = 6 \text{ bar}$$

$$T_1 = 800 \text{ K}$$

At exit,

$$p_2 = 1 \text{ bar}; \quad T_2 = 520 \text{ K}$$

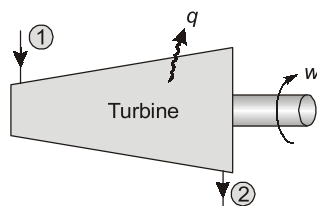

Surroundings temperature,

$$T_0 = 300 \text{ K}$$

Heat transfer,

$$q = -10 \text{ kJ/kg}$$

$$c_p = 1.0 \text{ kJ/kgK}$$

$$R = 0.3 \text{ kJ/kgK}$$

Applying the steady flow energy equation,

$$h_1 + \frac{V_1^2}{2} + gz_1 + q = h_2 + \frac{V_2^2}{2} + gz_2 + w$$

Neglect the change in kinetic and potential energies.

$$\therefore h_1 + q = h_2 + w$$

$$\text{or } w = (h_1 - h_2) + q$$

$$= c_p (T_1 - T_2) + q$$

$$= 1.0 (800 - 520) - 10$$

$$= 270 \text{ kJ/kg}$$

Maximum work output per unit mass,

$$w_{\max} = h_1 - h_2 - T_0 (s_1 - s_2)$$

$$= c_p (T_1 - T_2) - T_0$$

$$\left(c_p \log_e \frac{T_1}{T_2} - R \log_e \frac{p_1}{p_2} \right)$$

$$\begin{aligned}
 &= 1.0(800 - 520) - 300 \\
 &\quad \left(1.0 \log_e \frac{800}{520} - 0.3 \log_e \frac{6}{1}\right) \\
 &= 280 - 300(0.4307 - 0.5375) \\
 &= 280 + 32.04 = 312.04 \text{ kJ/kg}
 \end{aligned}$$

Irreversibility,

$$\begin{aligned}
 I &= w_{\max} - w = 312.04 - 270 \\
 &= \mathbf{42.04 \text{ kJ/kg}}
 \end{aligned}$$

Alternatively

Irreversibility,

$$\begin{aligned}
 I &= T_0 \Delta s_{\text{uni}} \\
 &= T_0 (\Delta s_{\text{sys}} + \Delta s_{\text{surr}}) \\
 &= T_0 \left[(s_2 - s_1) + \frac{q}{T_0} \right] \\
 &= 300 \left[\left(c_p \log_e \frac{T_2}{T_1} - R \log_e \frac{p_2}{p_1} \right) + \frac{10}{300} \right] \\
 &= 300 \left[\left(1.0 \log_e \frac{520}{800} - 0.3 \log_e \frac{1}{6} \right) + 0.0333 \right] \\
 &= 300 [-0.4307 + 0.5375 + 0.0333] \\
 &= \mathbf{42.03 \text{ kJ/kg}}
 \end{aligned}$$

3.3 Sol.

Actual work per kg,

$$\begin{aligned}
 w &= (h_1 - h_2) + q \\
 &= c_p (T_1 - T_2) + q \\
 &= 1.0(800 - 520) - 10 = \mathbf{270 \text{ kJ/kg}}
 \end{aligned}$$

Maximum work per kg air, w_{\max}

$$\begin{aligned}
 &= h_1 - h_2 - T_0 (s_1 - s_2) \\
 &= c_p (T_1 - T_2) - T_0 \left(c_p \log_e \frac{T_1}{T_2} - R \log_e \frac{p_1}{p_2} \right) \\
 &= 1.0(800 - 520) - 300 \left(1.0 \log_e \frac{800}{520} - 0.3 \log_e \frac{6}{1} \right) \\
 &= 280 + 32.04 = \mathbf{312.04 \text{ kJ/kg}}
 \end{aligned}$$

3.4 (c)

A gas turbine cycle is added with reheater and heat exchanger in order to improve the work output as well as the efficiency.



POINTS TO REMEMBER

If there is only reheating then work output increases and thermal efficiency decreases.

3.5 (c)

A gas turbine cycle with infinitely large number of stages during compression and expansion leads to constant temperature and constant pressure cycle i.e. Ericsson cycle. Ideally to get more work done.



- 4.1 Boiler rating is usually defined in terms of
- Maximum temperature of steam in kelvin
 - Heat transfer rate in kJ/hr
 - Heat transfer area in meter²
 - Steam output in kg/hr

[1992 : 2 Marks]

- 4.2 In steam and other vapour cycle, the process of removing non-condensable is called
- Scavenging process
 - Deaeration process
 - Exhaust process
 - Condensation process

[1992 : 2 Marks]



Answers Miscellaneous

- 4.1 (d) 4.2 (b)

Explanations Miscellaneous

4.1 (d)

Boiler rating is the heating capacity of a steam boiler and it is defined in terms of steam output in kg/hr.

4.2 (b)

Deaeration process: Deaeration process is one of the most important steps in boiler water treatment. It depends on the decrease in solubility of dissolved gases, notably O₂ and CO₂ as the water temperature is increased. The deaerator is a direct contact feed water heater.

Deaerator is used for removal of dissolved gases, mainly O₂ and CO₂. Presence of dissolved oxygen in feedwater is responsible for corrosion of metal tube.



POINTS TO REMEMBER

- Sodium sulphite (Na₂SO₃) or hydrazine (N₂H₄) is used for deoxygenation.
- Scavenging process is used in Internal Combustion engines.



IC Engines

UNIT IX

CONTENTS

1.	Air Standard Cycles	70
2.	Analysis and Injection of Fuel & Fuel Emission	71
3.	Testing and Performance	72
4.	Miscellaneous	73

1.1 In air standard Otto cycle the terminal pressures at the end of compression, heat release and expansion are respectively P_2 , P_3 and P_4 . If the corresponding values are P_2' , P_3' , and P_4' , taking into account the effect of variable specific heat and dissociation of the working fluid, then

- (a) $P_2 < P_2'$ and $P_3 > P_3'$
- (b) $P_3 < P_3'$ and $P_4 > P_4'$
- (c) $P_2 > P_2'$, $P_3 > P_3'$ and $P_4 < P_4'$
- (d) $P_2 > P_2'$, $P_3 > P_3'$ [1989 : 2 Marks]

1.2 An air standard diesel cycle consists of

- (a) Two adiabatic and two constant volume processes
- (b) Two constant volume and two isothermal processes

- (c) One constant pressure, one constant volume and two adiabatic processes
- (d) One constant pressure, one constant volume and two isothermal processes

[1990 : 2 Marks]

1.3 The figure below shows a thermodynamic cycle undergone by a certain system. Find the mean effective pressure in N/m^2

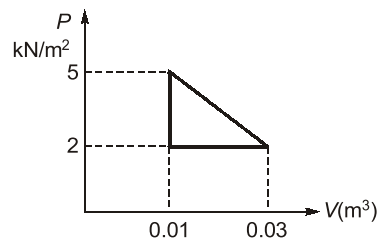

[1993 : 2 Marks]



Answers Air Standard Cycles

1.1 (d) 1.2 (c) 1.3 (1.5)

Explanations Air Standard Cycles

1.1 (d)

The terminal pressures at the end of compression, heat release and expansion i.e. p_2 , p_3 and p_4 respectively, will be greater than the corresponding values i.e. P_2' , P_3' and P_4' respectively, when we take into account the effect of variable specific heat and dissociation of the working fluid.

1.2 (c)

Air standard diesel cycle:

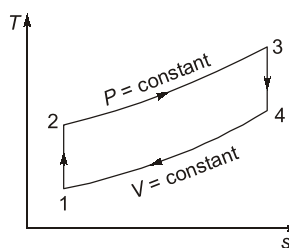
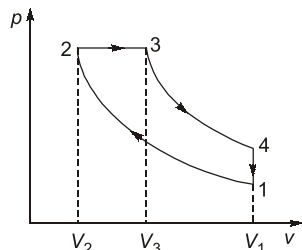

Process 1–2: Reversible adiabatic compression
 Process 2–3: Constant pressure heat addition
 Process 3–4: Reversible adiabatic expansion
 Process 4–1: Constant volume heat rejection

1.3 Sol.

$$\begin{aligned} \text{Work done} &= \text{Area under the cycle} \\ &= \frac{1}{2} \times 3 \times 0.02 = 0.03 \text{ kNm} \\ \text{mep} &= \frac{\text{Work done}}{\text{Volume}} = \frac{0.03}{0.02} \\ &= 1.5 \text{ kPa} \end{aligned}$$



2

Analysis and Injection of Fuel & Fuel Emission

- 2.1 The power output from a spark ignition engine is varied by
- Changing the ignition timing
 - Regulating the amount of air inducted
 - Regulating the amount of air fuel mixture
 - Regulating the amount of fuel

[1990 : 2 Marks]

- 2.2 BHP of a diesel engine can be increased by
- increasing the pressure of intake air
 - increasing the temperature of intake air
 - increasing the density of intake air
 - decreasing the density of intake air

[1991 : 2 Marks]

- 2.3 Alcohols are unsuitable at diesel engine fuels because

- The cetane number of alcohol fuels is very low which prevents their ignition by compression
- The cetane number of alcohol fuels is very high which prevents their ignition by compression
- The cetane number of alcohol fuels is very low which prevents good combustion
- None of these

[1992 : 2 Marks]



Answers Analysis and Injection of Fuel & Fuel Emission

2.1 (c) 2.2 (a, c) 2.3 (a)

Explanations Analysis and Injection of Fuel & Fuel Emission

2.1 (c)

The power output from a spark ignition engine is varied by regulating the amount of air-fuel mixture i.e. by supplying richer or leaner mixture.



POINTS TO REMEMBER

- In a spark ignition engine, ignition timing refers to the timing, relative to the current piston position and crankshaft angle, of the release of a spark in the combustion chamber near the end of the compression stroke.
- The need for advancing or retarding the timing of the spark is because fuel doesn't completely burn the instant the spark fires.

2.2 (a, c)

By $p_a \uparrow \Rightarrow$ Supercharged \uparrow
 \Rightarrow I.P. \Rightarrow B.P. \uparrow

2.3 (a)

Alcohols are unsuitable as diesel fuels for the following reasons.

- The cetane number of alcohol fuels is very low (of the order of zero to eight), which prevents their ignition by compression.
- Alcohol fuels have low lubricating qualities causing trouble in injection pumps and nozzles
- There are material problems caused by the harsh reaction of methanol towards various plastics and metals.



- 3.1 Brake thermal efficiency of the three basic types of reciprocating engines commonly used in road vehicles are given in the increasing order as
- (a) 2 Stroke SI engine, 4 Stroke SI engine, 4 Stroke CI engine
 - (b) 2 Stroke SI engine, 4 Stroke CI engine, 4 Stroke SI engine
 - (c) 4 Stroke SI engine, 2 Stroke SI engine, 4 Stroke CI engine
 - (d) 4 Stroke CI engine, 4 Stroke SI engine, 2 Stroke SI engine

[1992 : 2 Marks]



Answers Testing and Performance

3.1 (a)

Explanations Testing and Performance

3.1 (a)

Brake thermal efficiency of diesel engine is higher than the petrol engine. At the same time, four stroke engines have more efficiency than the 2-stroke engines.



POINTS TO REMEMBER

Volumetric efficiency of diesel engine is also higher than the petrol engine.



- 4.1 For determining the ignition quality of compression ignition engine fuels, the reference fuels used are
- Isooctane and n-heptane
 - Cetane and α -methyl naphthalene
 - Hexadecane and n-heptane
 - Cetane and isooctane

[1991 : 2 Marks]

- 4.2 If air fuel ratio of the mixture in petrol engine is more than 15 : 1

- NO_x is reduced
- CO_2 is reduced
- HC is reduced
- CO reduced

[1991 : 2 Marks]

- 4.3 Knocking tendency in a SI engine reduces with increasing

- Compression ratio
- Wall temperature
- Supercharging
- Engine speed

[1993 : 2 Marks]

■■■■

Answers Miscellaneous of I.C. Engines

- 4.1 (b) 4.2 (a) 4.3 (d)

Explanations Miscellaneous of I.C. Engines

4.2 (a)

If air-fuel ratio of the mixture in petrol engine is more than 15 : 1 it means that the mixture is lean, leaner AFR (air-fuel ratio) results in higher temperatures as the mixture is combusted. As we know, maximum NO_x is produced at AFR between 14 : 1 to 15 : 1, so when the air-fuel ratio is more than 15 : 1 then the NO_x formation reduces.

4.3 (d)

Knocking tendency in a SI engine reduces with increasing

- Turbulence
- Engine speed
- Self ignition temperature of fuel
- Octane rating

■■■■

Refrigeration and Air-conditioning

UNIT

X

CONTENTS

- | | | |
|----|-------------------------|----|
| 1. | Vapour Refrigeration | 75 |
| 2. | Psychrometric Process | 76 |
| 3. | Heat Pumps and Cycles | 77 |
| 4. | Properties of Moist Air | 78 |

1.1 Round the clock cooling of an apartment having a load of 300 MJ/day requires an air conditioning plant of capacity about

- (a) 1 ton (b) 5 tons
(c) 10 tons (d) 100 tons

[1993 : 2 Marks]

1.2 The use of Refrigerant R-22 for temperature below -30°C is not recommended due to its

- (a) good miscibility with lubricating oil
(b) poor miscibility with lubricating oil
(c) low evaporating temperature
(d) high compressor discharge temperature

[1993 : 2 Marks]



Answers Vapour Refrigeration

1.1 (a) 1.2 (b)

Explanations Vapour Refrigeration

1.1 (a)

$$\begin{aligned} \text{Capacity: } \dot{Q} &= 300 \text{ MJ/day} \\ &= \frac{300 \times 10^3}{24 \times 60 \times 60} \text{ kJ/s} = 3.47 \text{ kW} \\ &\quad (\therefore 1 \text{ ton} = 3.5 \text{ kW}) \\ \therefore &= \frac{3.47}{3.5} = 0.99 \text{ ton} \approx \mathbf{1 \text{ ton}} \end{aligned}$$

1.2 (b)

R-22 has a limit upto which it is miscible with lubricating oil. And its miscibility reduces as temperature goes down so Refrigerant R-22 is not recommended with very low temperature.



POINTS TO REMEMBER

Refrigerant R-22 is used with the reciprocating compressors generally. It is used in window a.c. and large units such as package units and large a.c. plants.



- 2.1 Wet bulb depression, under saturated ambient air conditions:
- is always positive
 - is always negative
 - is always zero
 - May have a value depending upon the dew point temperature

[1989 : 2 Marks]



Answers Psychrometric Process

2.1 (c)

Explanations Psychrometric Process

2.1 (c)

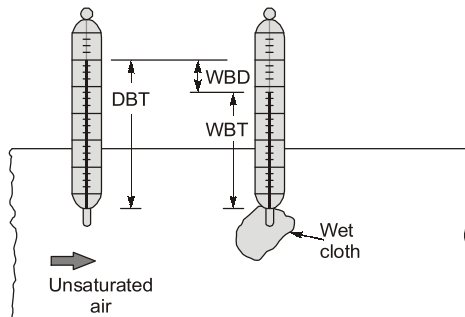
DBT — Dry bulb temperature
 WBT — Wet bulb temperature
 WBD — Wet bulb depression



$$WBD = DBT - WBT$$

$WBD \neq 0$ for unsaturated air $\therefore DBT > WBT$

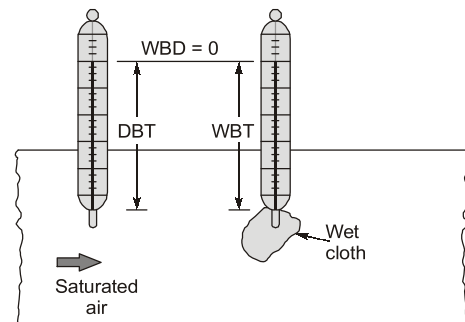

$WBD = 0$ for saturated air $\therefore DBT = WBT$



3.1 A refrigeration compressor, designed to operate with R 22 _____ (can/cannot) be operated with R 12 because the condensing pressure of R 22 at any given temperature is (higher/lower) than that of R 12.

[1992 : 2 Marks]

■ ■ ■ ■

Answers Heat Pumps and Cycles

3.1 (cannot, higher)

Explanations Heat Pumps and Cycles

3.1 Sol.

cannot, higher.



POINTS TO REMEMBER

- Refrigerant, R-11 is generally used in large capacity central a.c. plants having centrifugal compressor.
- Refrigerant, R-12 is generally used in small units, specially domestic refrigerators, water coolers etc, having reciprocating compressor.

■ ■ ■ ■

- 4.1 Atmospheric air from 40°C and 60 percent relative humidity can be brought to 20°C and 60 percent relative humidity by
- Cooling and dehumidification process
 - Cooling and humidification process
 - Adiabatic saturation process
 - Sensible cooling process

[1990 : 2 Marks]

- 4.2 If moist air is cooled by sensible heat removal, which of the following is true?

- Neither relative humidity nor specific humidity changes
- Specific humidity changes but not relative humidity
- Both relative humidity and specific humidity changes
- None of these

[1991 : 2 Marks]



Answers Properties of Moist Air

4.1 (a) 4.2 (d)

Explanations Properties of Moist Air

4.1 (a)

Cooling and dehumidification process,
DBT ↓, ω ↓

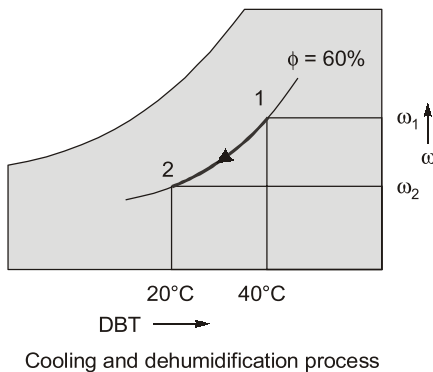

4.2 (d)

Sensible cooling process,
DBT ↓, ω = C, φ ↑

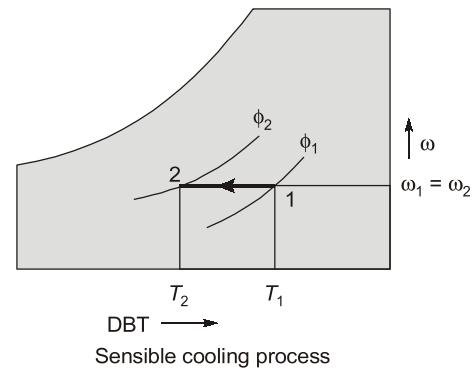

Manufacturing Engineering

UNIT XI

CONTENTS

1.	Engineering Materials	80
2.	Metal Casting	81
3.	Metal Forming	84
4.	Sheet Metal Operations	85
5.	Joining/Welding	86
6.	Machining and Machine Tool Operation	88
7.	Metrology and Inspection	91
8.	NC, CNC, DNC, APT, Automation	92
9.	Nonconventional Machining (EDM, High Energy Rate Forming)	93

- 1.1 When 1.0% plain carbon steel is slowly cooled from the molten state to 740°C, the resulting structure will contain
- (a) Pearlite and cementite
 - (b) Ferrite and cementite
 - (c) Austenite and ferrite
 - (d) Austenite and cementite

[ME 1990 : 1 Mark]



Answers Engineering Materials

1.1 (d)

- 2.1 Riser is designed so as to
 (a) freeze after the casting freezes
 (b) freeze before the casting freezes
 (c) freeze at the same time as the casting
 (d) minimize the time of pouring
[ME 1987 : 1 Mark]
- 2.2 The contraction allowance provided on the pattern and core boxes compensates for the following type of contraction
 (a) liquid contraction
 (b) solidification contraction
 (c) solid contraction
 (d) All of the above three types of contractions
[ME 1988 : 1 Mark]
- 2.3 Chills are used in moulds to
 (a) achieve directional solidification
 (b) reduce possibility of below holes
 (c) reduce the freezing time
 (d) smoothen the metal for reducing spatter
[ME 1989 : 1 Mark]
- 2.4 Increase in water content in moulding sand causes
 (a) flowability to go through a maxima
 (b) permeability to go through a maxima
 (c) compressive strength to go through a maxima
 (d) strength to go through a maxima
[ME 1989 : 1 Mark]
- 2.5 Two cubical castings of the same metal and sizes of 2 cm side and 4 cm side are moulded in green sand. If the smaller casting solidifies in 2 mins, the expected time of solidifications of large casting will be
 (a) 16 min (b) $2\sqrt{8}$ min
 (c) 8 min (d) 4 min
[ME 1989 : 2 Marks]
- 2.6 The pressure at the in-gate will be maximum with the gating system
 (a) 4 : 8 : 3 (b) 1 : 3 : 3
 (c) 1 : 2 : 4 (d) 1 : 2 : 1
[ME 1990 : 1 Mark]
- 2.7 When there is no room temperature change, the total shrinkage allowance on a pattern is independent of
 (a) pouring temperature of the liquid metal
 (b) freezing temperature of the liquid metal
 (c) the component size
 (d) coefficient of thermal contraction of solidified metal
[ME 1991 : 1 Mark]
- 2.8 Converging passage is used for feeding the liquid molten metal into the mould to
 (a) increase the rate of feeding
 (b) quickly break off the protruding portion of the casting
 (c) decrease wastage of cast metal
 (d) avoid aspiration of air
[ME 1991 : 1 Mark]
- 2.9 In a green sand moulding process, uniform ramming leads to
 (a) less chance of gas porosity
 (b) uniform flow of molten into the mould cavity
 (c) greater dimensional stability of the casting
 (d) less sane expansion type of casting defect
[ME 1992 : 1 Mark]
- 2.10 Casting process
 A. Slush casting
 B. Shell moulding
 C. Dry sand moulding
 D. Centrifugal casting
Product
 1. Turbine blade
 2. Machine tool bed
 3. Cylindrical block
 4. Hollow castings like lamp shades
 5. Rain water pipes
 6. Cast iron shoe brake
[ME 1992 : 2 Marks]
- 2.11 Centrifugally casted products have
 (a) large grain structure with high porosity
 (b) fine grain structure with high density

- (c) fine grain structure with low density
 (d) segregation of slug toward the outer skin of the casting

[ME 1993 : 1 Mark]

2.12 Only 4 pairs can be matched

Casting process

- A. Investment casting
 B. Die casting
 C. Centrifugal casting
 D. Drop forging
 E. Extrusion
 F. Shell moulding

Product

1. Turbine rotors
2. Turbine blades
3. Connecting rods
4. Galvanized iron pipes
5. Cast iron pipes
6. Carburetor body

[ME 1994 : 2 Marks]

■■■■

Answers Metal Casting

- 2.1 (a) 2.2 (c) 2.3 (a) 2.4 (b) 2.5 (c) 2.6 (d) 2.7 (a) 2.8 (d)
 2.9 (c) 2.10 (A-4, B-3, C-2, D-5) 2.11 (b) 2.12 (A-2, B-6, C-5, D-3, E-4, F-1)

Explanations Metal Casting**2.1 (a)**

Since, riser acts as a reservoir of molten metal to mould cavity, it is so designed as to freeze after the casting freezes.

2.2 (c)

After freezing, solid shrinkage takes place as material cools from freezing temperature to room temperature. Contraction or shrinkage allowance is provided on pattern to compensate for this.

2.3 (a)

Chills (metal pieces) are provided to increase cooling rate and to achieve directional solidification.

2.5 (c)

$$\text{Modulus} = \frac{V}{A}$$

$$\text{For cube 1, } M_1 = \frac{2^3}{6 \times 2^2} = \frac{8}{24} = \frac{1}{3}$$

$$\text{For cube 2, } M_2 = \frac{4^3}{6 \times 4^2} = \frac{64}{96} = \frac{2}{3}$$

$$\text{Solidification time} \propto \left(\frac{V}{A}\right)^2 \text{ i.e. } t_s \propto M^2$$

Hence, we have

$$\frac{T_1}{T_2} = \frac{M_1^2}{M_2^2}$$

$$\text{Given } T_1 = 2 \text{ min}$$

$$\Rightarrow T_2 = 2 \times \left(\frac{2}{3}\right)^2 \times \left(\frac{3}{1}\right)^2 = 8 \text{ min}$$

2.6 (d)

Gating ratio denotes sprue area : runner area : gate area.

$a : b : c \Rightarrow$ sprue area : runner area : gate area
 If ingate area is less pressure is more due to back flow of liquid metal.

2.7 (a)

$$\text{Shrinkage} = \alpha A (T_f - T_a),$$

where

α = coefficient of thermal contraction

A = Pattern/mould cross-section area

T_f = Freezing temperature

T_a = Ambient temperature

Solid shrinkage is independent of pouring temperature.

2.8 (d)

Converging passages are used as sprues to gain in velocity of molten metal as it reduces air aspiration.

2.9 (c)

Uniform ramming of sand during mould preparation improves mould strength, and makes it dimensionally stable.

2.10 Sol.

A-4, B-3, C-2, D-5

Slush casting is used for making lamp shades, decorative pots etc. Symmetrical jobs like cylinder heads of IC engines are made with shell casting. Machine tool beds are casted using sand moulding. Hollow cylindrical parts are made with the help of centrifugal casting due to centrifugal effect.

2.11 (b)

In centrifugal casting, fine grain structure with high density is obtained due to centrifugal action. Slug segregation is toward internal skin of casting.

2.12 Sol.

A-2, B-6, C-5, D-3, E-4, F-1

Complex shape are made with investment casting connecting rods are made using forging operation.



- 3.1** For wire drawing operation, the work material should essentially be
 (a) ductile (b) tough
 (c) hard (d) malleable
[ME 1987 : 1 Mark]
- 3.2** In forging operation the sticking friction condition occurs near the ... (centre/ends)
[ME 1987 : 1 Mark]
- 3.3** The true sliding strain for a low carbon steel bar which is doubled in length by forging is
 (a) 0.307 (b) 0.5
 (c) 0.693 (d) 1.0
[ME 1992 : 1 Mark]
- 3.4** The process of hot extrusion is used to produce
 (a) Curtain rods made of aluminium
 (b) Steel pipes of domestic water supply
 (c) Stainless steel tubes used in furniture
 (d) Large size pipes used in city water mains
[ME 1994 : 1 Mark]
- 3.5** Calculate the bite angle when rolling plates 12 mm thick using work rolls 600 mm diameter and reducing the thickness by 3 mm
[ME 1994 : 2 Marks]
-

Answers Metal Forming

3.1 (a) 3.2 (centre) 3.3 (c) 3.4 (a) 3.5 (5.73)

Explanations Metal Forming

3.1 (a)

For wire drawing, ductility is essential criterion.

3.2 Sol.

In forging operation the sticking friction condition occurs near the **centre**.

3.3 (c)

Engineering strain:

$$\epsilon = \frac{2l - l}{l} = 1$$

True strain = $\ln(1 + \epsilon) = \ln 2 = 0.693$

3.5 Sol.

$$\text{Bite angle: } \theta = \tan^{-1} \left(\frac{\sqrt{R\Delta h}}{R - \frac{\Delta h}{2}} \right)$$

Here, $\Delta h = 3$ mm, $R = 300$ mm

$$\theta = \tan^{-1} \left(\frac{\sqrt{300 \times 3}}{300 - 1.5} \right) = 5.73^\circ$$

■■■■

4

Sheet Metal Operations

4.1 For blanking and piercing operations, clearance is provided on the ... and the .. respectively.

[ME 1987 : 1 Mark]

4.2 Wrinkling is a common defect found is

- (a) Bent components
- (b) Deep drawn components
- (c) Embossed components
- (d) Blanked component

[ME 1991 : 1 Mark]

4.3 The thickness of the blank needed to produce, by power spinning a missile cone of thickness 1.5 mm and half cone angle 30°

- (a) 3.0 mm
- (b) 2.5 mm
- (c) 2.0 mm
- (d) 1.5 mm

[ME 1992 : 2 Marks]

4.4 In deep drawing of sheets, the values of limiting drawing ratio depends on

- (a) percentage elongation of the sheet
- (b) yield strength of the sheet
- (c) type of press used
- (d) thickness of sheet

[ME 1994 : 1 Mark]



Answers Sheet Metal Operations

4.1 (Punch and die) 4.2 (b) 4.3 (a) 4.4 (d)

Explanations Sheet Metal Operations

4.1 Sol.

In blanking, size is controlled by die hence clearance is provided on punch. Similarly in case of piercing, size of hole is controlled by punch, therefore clearance is provided on die.

4.2 (b)

During deep drawing operation, edges of the blank lifts up and wrinkles are formed due to circumferential compressive stresses.

4.3 (a)

Thickness of blank

$$= \frac{\text{cone thickness}}{\cos(2\alpha)} = \frac{1.5}{\cos 60^\circ} = 3.0 \text{ mm}$$

4.4 (d)

Limiting drawing ratio (LDR) is an indication of formability of material. Larger thickness sheets will exhibit larger value of LDR.



- 5.1 Penetration is increased by
- Increasing welding current and welding speed
 - Increasing welding current and decreasing welding speed
 - Decreasing welding current and welding speed
 - Decreasing welding current and increasing welding speed

[ME 1990 : 1 Mark]

- 5.2 At small variations of arc length at operating conditions, the manual metal arc welding transformer provides nearly
- Constant power
 - Constant power factor
 - Constant voltage
 - Constant current

[ME 1990 : 1 Mark]

- 5.3 For gas welding a particular job using a neutral oxyacetylene flame the acetylene consumption was 10 litres. The oxygen consumption from the cylinder in liters will be

- 5
- 10
- 15
- 20

[ME 1991 : 1 Mark]

- 5.4 For resistance spot welding of 1.5 mm thick steel sheets, the current required is of the order

- 10 Amp
- 100 Amp
- 1000 Amp
- 10,000 Amp

[ME 1991 : 1 Mark]

- 5.5 Welding process

- Thermit welding
- Seam welding
- MIG welding
- Friction welding

Heat source

- Chemical reaction
- Exothermic chemical reaction
- Electric spark
- Ohmic resistance
- Mechanical work
- Electric arc

[ME 1991 : 2 Marks]

- 5.6 In an explosive welding process, the (maximum/minimum) velocity of impact is fixed by the velocity of sound in the (flyer/ target) plate material.

[ME 1992 : 1 Mark]

- 5.7 In DC welding, the straight polarity (electrode negative) results in

- Lower penetration
- Lower deposition rate
- Less heating of work piece
- Smaller weld pool

[ME 1993 : 1 Mark]

- 5.8 The electrodes used in arc welding are coated. This is not expected to

- Provide protective atmosphere to weld
- Stabilize the arc
- Add alloying elements
- Prevent electrode from contamination

[ME 1994 : 1 Mark]

- 5.9 The ratio of acetylene to oxygen is approximately for neutral flame used in gas welding

[ME 1994 : 1 Mark]

■■■■■

Answers Joining/Welding

- 5.1 (b) 5.2 (d) 5.3 (b) 5.4 (d) 5.5 (A-2, B-4, C-6, D-5)
 5.6 (Maximum, flyer) 5.7 (b) 5.8 (d) 5.9 (1 : 1)

Explanations Joining/Welding**5.1 (b)**

On increasing currents, heat generated will increase and reducing speed will give more time to heat to accumulate hence increasing weld penetration.

5.2 (d)

Manual metal arc welding transformer provides nearly constant current power source for small change in arc length.

5.3 (b)

For neutral oxy acetylene flame, ratio between oxygen and acetylene is approx 1 : 1, hence in this case oxygen consumption will be **10 litres**, from the cylinder.

5.4 (d)

For resistance spot welding, current required
= $3937 (t_1 + t_2)$ Ampere
= $3937 (1.5 + 1.5)$
= $118115 \approx 10000$ Amp.

5.6 Sol. Maximum, flyer

In an explosive welding process, the maximum velocity of impact is fixed by the velocity of sound in flyer plate.

5.7 (b)

In straight polarity, electrode is negative and workpiece is +ve, hence more heat is generated at workpiece resulting in greater penetration but due to lower heat generation at electrode end, melting rate of electrode reduces causing low deposition rate.

5.8 (d)

Coatings are provided to produce shielding gasses, remove oxides, stabilize the arc and provide alloying elements to improve strength and physical properties of the weld metal.

5.9 Sol.

In neutral flame ratio of acetylene to oxygen by vol is 1 : 1.



- 6.1** The standard specification of a grinding wheel is A-46-M-6-V-21. It means a wheel of
 (a) Aluminum oxide of mesh size 6
 (b) Boron carbide of mesh size 46
 (c) Aluminum oxide of mesh size 46
 (d) Silicon carbide of mesh size 6
[ME 1987 : 1 Mark]
- 6.2** Cutting tools are provided with large positive rake angle mainly for
 (a) Increasing the strength of the cutting edge
 (b) Avoiding rubbing action with the finished surfaces
 (c) Reducing the magnitude of the cutting force
 (d) Better heat dissipation **[ME 1987 : 1 Mark]**
- 6.3** If in a turning operation both the feed rate and the nose radius are doubled the surface finish value will be
 (a) Decreases by 50%
 (b) Increases by 300%
 (c) Increases by 100%
 (d) Rumanian affected **[ME 1987 : 1 Mark]**
- 6.4** The ideal cutting fluid for low speed machining of metals should be one which
 (a) removes the heat faster from the cutting zone
 (b) forms a coating on the cutting tools by chemical reaction
 (c) forms a low shear strength film of work material at the tool chip interface
 (d) serves as a dielectric, minimizing thereby reactions due to EMF at the interface
[ME 1988 : 1 Mark]
- 6.5** In twist drills.... (small/large) point angle and ... (small/large) helix angle are provided for drilling soft, low strength steel.
[ME 1988 : 1 Mark]
- 6.6** Cutting speed in grinding is set to a high value to
 (a) Reduce the cutting time
 (b) Increase the bond strength
 (c) Improve cooling of job and wheel
 (d) Reduce the wheel wear
[ME 1988 : 1 Mark]
- 6.7** Pure metal pose machinability problem in turning operations. The reason is the
 (a) Increased length of contact due to the production of continuous chip
 (b) Susceptibility to chemical reactions
 (c) Tendency to from intense adhesion joint with the tool face
 (d) Absence of inclusions which aids chip formation **[ME 1988 : 2 Marks]**
- 6.8** The size of BUE in metal cutting increases with
 (a) very high speed
 (b) large uncut chip thickness
 (c) use of cutting fluid
 (d) increase in positive rake angle
[ME 1989 : 1 Mark]
- 6.9** Crater wear always starts at some distance from the tool tip because at that point
 (a) cutting fluid does not penetrate
 (b) chip tool interface temp is maximum
 (c) normal stress on rake face is maximum
 (d) tool strength is minimum
[ME 1989 : 1 Mark]
- 6.10** Gear hobbing produces more accurate gears than milling because in hobbing
 (a) there is a continuous indexing operation
 (b) pressure angle is larger than in milling
 (c) hob and work piece both are rotating
 (d) a special multi-tooth cutter (hob) is used
[ME 1989 : 1 Mark]
- 6.11** Teeth of internal spur gears can be accurately cut in a
 (a) Milling machine
 (b) Gear shaping machine
 (c) Slotting machine
 (d) Hobbing machine **[ME 1989 : 1 Mark]**
- 6.12** Minimum dimensional and form accuracy can be obtained in the cylinder bores of automobile engines if the bores are finished by
 (a) Lapping (b) Reaming
 (c) Internal grinding (d) Honing
[ME 1989 : 1 Mark]

- 6.13** In turning operation the feed rate could be doubled to increase the metal removal rate. To keep the same level of surface finish, the nose radius of the tool has to be
 (a) Doubled
 (b) Halved
 (c) Multiplied by 4 times
 (d) Kept unchanged [ME 1989 : 2 Marks]
- 6.14** Most of the metal cutting heat goes into the
 (a) Moving chip (b) Cutting tool
 (c) Work material (d) Machine tool
 [ME 1990 : 1 Mark]
- 6.15** If the longitudinal feed in centreless grinding is expressed by $V_f = \pi DN \sin\alpha$, D stands for
 (a) Diameter of blank
 (b) Diameter of finished workpiece
 (c) Diameter of control wheel
 (d) Diameter of grinding wheel
 [ME 1990 : 1 Mark]
- 6.16** In small lot production for machining T-slots on machine tables, it is expected to use
 (a) Shaping machine
 (b) Broaching machine
 (c) Vertical milling machine
 (d) Horizontal milling machine
 [ME 1990 : 1 Mark]
- 6.17** For cutting double start screw threads of pitch 1.0 mm on a lathe, the thread cutting tool should have a feed rate of
 (a) 0.5 mm/rev (b) 1.0 mm/rev
 (c) 2.0 mm/rev (d) 4.0 mm/rev
 [ME 1991 : 2 Marks]
- 6.18** A milling cutter having 10 teeth is rotating at 100 rpm. The table feed is set at 50 mm per minute. The feed per tooth in mm is
 (a) 5 (b) 0.5
 (c) 0.2 (d) 0.05
 [ME 1991 : 2 Marks]
- 6.19** The effect of rake angle on the mean friction angle in machining can be explained by
 (a) Sliding model of friction
 (b) Sticking and then sliding friction model
 (c) Sticking friction model
 (d) Sliding and then sticking friction model
 [ME 1992 : 1 Mark]
- 6.20** In horizontal milling process (up/down) milling provides better surface finish and (up/down) milling provide longer tool life.
 [ME 1992 : 1 Mark]
- 6.21** Component process
 A. Square hole in a high strength alloy
 B. Square hole in a ceramic component
 C. Blind holes in a die
 D. Turbine blade profile on high strength alloy
 1. Milling
 2. Drilling
 3. ECM
 4. Jig boring
 5. EDM
 6. USM
 [ME 1992 : 2 Marks]
- 6.22** A milling cutter having 8 teeth is rotating at 150 rpm. If the feed per tooth is 0.1 mm, the speed in mm per minute is
 (a) 120 (b) 187
 (c) 125 (d) 70
 [ME 1993 : 2 Marks]
- 6.23** To get good surface finish on a turned job, one should use a sharp tool with ... feed rate and ... speed of rotation of the job.
 [ME 1994 : 1 Mark]
- 6.24** A grinding wheel A 27 K 7 V is specified for finish grinding of a HSS cutting tool. What do you understand about the wheel from the above code. IS this an appropriate choice?
 (a) yes
 (b) no, because abrasive is not correct
 (c) no, grain size is not correct
 (d) no, because grade is not correct choice
 [ME 1994 : 2 Marks]



Answers Machining and Machine Tool Operation

- 6.1** (c) **6.2** (c) **6.3** (c) **6.4** (a) **6.5** (small, large) **6.6** (a) **6.7** (a) **6.8** (b)
6.9 (b) **6.10** (a) **6.11** (b) **6.12** (d) **6.13** (c) **6.14** (a) **6.15** (c) **6.16** (c)
6.17 (c) **6.18** (d) **6.19** (b) **6.20** (down, down) **6.21** A-5, B-6, C-2, D-3 **6.22** (a)
6.23 (small, high) **6.24** (c)

Explanations Machining and Machine Tool Operation**6.5 Sol.**

Small/large.

6.7 (a)

Generally pure metals have high ductility, hence the continuous chips are produced.

6.17 (c)

Feed in thread cutting = lead of threads
= number of starts \times pitch
= $2 \times 1.0 = 2 \text{ mm/rev}$

6.20 Sol.

In horizontal milling process **down** milling provides better surface finish and **down** milling provide longer tool life.

6.22 (a)

Teeth on milling cutter = 8

rpm = 150

Feed per tooth, $f_t = 0.1 \text{ mm}$

Feed per revolution = feed per tooth \times no. of teeth
= $0.1 \times 8 = 0.8 \text{ mm/rev.}$

speed = $0.8 \times 150 \text{ mm/min}$

= **120 mm/min**

6.23 Sol.

To get good surface finish on a turned job, one should use a sharp tool with **small** feed rate and **high** speed of rotation of the job.



- 7.1 The hole $40_{+0.000}^{+0.020}$ and shaft, $40_{-0.010}^{+0.010}$ when assembled will result in
 (a) clearance fit (b) interference fit
 (c) transition fit (d) drive fit
[ME 1987 : 1 Mark]

- 7.2 In an engineering drawing one finds the designation of 20G7f8, the position of tolerance of the hole is indicated by
 (a) Letter G (b) Letter f
 (c) Number 7 (d) Number 8
[ME 1988 : 1 Mark]
[ME 1989 : 1 Mark]

- 7.3 A bush was turned after mounting the same on a mandrel. The mandrel diameter in millimeters is $40_{-0.05}^{+0.00}$ and bore diameter of bush is $40_{-0.010}^{+0.06}$. The maximum eccentricity of the bush in mm will be
 (a) 0.01 (b) 0.055
 (c) 0.1 (d) 0.11
[ME 1991 : 2 Marks]

- 7.4 Two shafts *A* and *B* have their diameters specified as 100 ± 0.1 mm and 0.1 ± 0.0001 mm respectively. Which of the following statements is/are true
 (a) Tolerance in the dimension is greater in shaft *A*
 (b) The relative error in the dimension is greater in shaft *A*
 (c) Tolerance in the dimension is greater in shaft *B*
 (d) The relative error in the dimension is same for shaft *A* and shaft *B*
[ME 1992 : 2 Marks]

- 7.5 A shaft of diameter $20_{-0.15}^{+0.05}$ mm and a hole of diameter $20_{+0.10}^{+0.20}$ mm when assembled would yield
 (a) Transition fit (b) Interference fit
 (c) Clearance fit (d) None of these
[ME 1993 : 2 Marks]

■ ■ ■ ■

Answers Metrology and Inspection

7.1 (c) 7.2 (a) 7.3 (b) 7.4 (a) 7.5 (c)

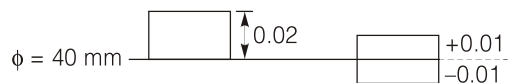
Explanations Metrology and Inspection**7.1 (c)****7.2 (a)**

The position of tolerance zone with respect to the zero line, which is a function of the basic size, is indicated by letter symbol, a capital letter for holes and a small letter for shafts. The tolerance, the value of which is a function of the basic size is designated by a number symbol, called the grade.

7.3 (b)

Max. dia of bushing = 40.06 mm
 Min. dia of mandrel = 39.95 mm

$$\begin{aligned} \text{Maximum eccentricity} &= \text{Max. radial clearance} \\ &= \frac{40.06 - 39.95}{2} = 0.055 \text{ mm} \end{aligned}$$

7.4 (a)

Tolerance of shaft *A*
 $= 100.1 - 99.9 = 0.2$ mm
 Tolerance of shaft *B*
 $= 0.1001 - 0.0999 = 0.0002$ mm
 So, tolerance of shaft *A* > Tolerance of shaft *B*

7.5 (c)

Max. diameter for shaft = 20.05 mm
 Min. diameter for shaft = 19.85 mm
 Similarly min. diameter for hole = 20.10 mm
 Since, min. diameter for hole is greater than max. diameter of shaft, it is a case of clearance fit.

■ ■ ■ ■

- 8.1 In NC part programming spindle speed of 730 rpm will be coded by the magic -3 rule as
 (a) S673 (b) S730
 (c) S630 (d) S037
[ME 1989 : 1 Mark]
- 8.2 Numerically controlled machine tools are better suited for ... (batch/mass) production, because their setup time is.... (larger/smaller) in comparison to special purpose machine tools
[ME 1991 : 1 Mark]
- 8.3 In PTP type of NC system
 (a) Control of position and velocity of the tool is essential
 (b) Control of only position of the tool is sufficient
 (c) Control of only velocity of the tool is sufficient
 (d) Neither position nor velocity need be controlled
[ME 1992 : 1 Mark]
- 8.4 With reference to NC machine, which of the following statement is wrong?
 (a) Both closed loop and open loop control systems are used
 (b) Paper tapes, floppy drives and cassettes are used for data storage
 (c) Digitisers may be used as interactive input devices
 (d) Post-processor is an item of hardware
[ME 1993 : 2 Marks]
- 8.5 CNC machines are more accurate than conventional machines because they have a high resolution encoder and digital readouts for positioning. (T/F) **[ME 1994 : 1 Mark]**
- 8.6 CNC machines are more economical to use even for simple turning jobs. (T/F)
[ME 1994 : 1 Mark]

■ ■ ■ ■

Answers NC, CNC, DNC, APT, Automation

8.1 (a) 8.2 (Mass and smaller) 8.3 (b) 8.4 (d) 8.5 (True) 8.6 (False)

Explanations NC, CNC, DNC, APT, Automation**8.2 Sol.**

Set-up time for NC machines is **smaller** in comparison to special purpose machines hence, used for **batch** production.

8.3 (b)

In point to point type of NC system, only end position of tool is controlled. Neither path nor velocity of the tool is important.

8.4 (d)

Post-processor is not used in NC machine.

8.5 Sol.

True

8.6 Sol.

False

■ ■ ■ ■

9

Nonconventional Machining (EDM, High Energy Rate Forming)

- 9.1 In ultrasonic machining the tool... at very high frequency with the help of ... transducers.
[ME 1987 : 1 Mark]
- 9.2 ECM... (can/cannot) be used for all such materials for which ultrasonic machining is possible, while EDM ... (can/cannot) be used for all such materials for which ECM is possible.
[ME 1987 : 1 Mark]
- 9.3 In ECM, the material removal rate will be higher for metal with
(a) large density
(b) larger valency
(c) larger chemical absorption tendency
(d) large chemical weight
[ME 1989 : 2 Marks]
- 9.4 In USM the metal removal rate would ... with increasing mean grain diameter of the abrasive material
(a) increase
(b) decrease
(c) increase and then decrease
(d) decrease and then increase
[ME 1992 : 1 Mark]
- 9.5 The two main criteria for selecting the electrolyte in ECM is that the electrolyte should
(a) chemically stable
(b) not allow dissolution of cathode material
(c) not allow dissolution of anode material
(d) have high electrical conductivity
[ME 1992 : 1 Mark]
- 9.6 In ultrasonic machining process, the material removal rate will be higher for material with
(a) higher toughness
(b) higher ductility
(c) lower toughness
(d) higher fracture strain [ME 1993 : 1 Mark]
- 9.7 EDM imposes larger forces on tool than ECM (T/F)
[ME 1994 : 1 Mark]
- 9.8 EDM is more efficient process than ECM for producing large non-circular holes (T/F)
[ME 1994 : 1 Mark]
- 9.9 USM is about the best process for making holes in glass which are comparable in size with thickness of the sheet. [ME 1994 : 1 Mark]
- 9.10 Generally cylindrical parts produced by powder metallurgy should not have nonuniform cross section and length to diameter ratio exceeding.
[ME 1994 : 1 Mark]
-

Answers Nonconventional Machining

- 9.1 (Vibrate, magnetostrictive) 9.2 (Cannot, can) 9.3 (d) 9.4 (c) 9.5 (b, d) 9.6 (c)
9.7 (False) 9.8 (True) 9.9 (True) 9.10 (2.5)

Explanations Nonconventional Machining**9.1 Sol. Vibrate, magnetostrictive**

In ultrasonic machining the tool vibrates at very high frequency with the help of magnetostrictive transducer.

9.2 Sol. Cannot, can

ECM and EDM can be done for conductive material while ultrasonic machining can be done on any material.

9.3 (d)

For ECM, $MRR \propto$ atomic weight of material.

9.6 (c)

In USM, mode of material removal is brittle fracture, therefore material removal rate will be higher for material with lower toughness.

9.7 Sol. FALSE

EDM is a non-contact type machining while in ECM material removal takes place through ion displacement.

9.9 Sol. TRUE

USM is used for machining, non-conducting brittle materials like ceramics and glass as material removal takes place through brittle fracture.

9.10 Sol.

Generally cylindrical parts produced by powder metallurgy should have length to diameter ratio less than or equal to 2.5



Industrial Engineering

UNIT XII

CONTENTS

- | | | |
|----|---|----|
| 1. | Inventory Control & Break-Even Analysis | 96 |
| 2. | PERT and CPM | 97 |

Inventory Control & Break-Even Analysis

1.1 In an ideal inventory control system, the economic lot size for a part is 1000. If the annual demand for the part is doubled, the new economic lot size required will be

- (a) 500 (b) 2000
(c) $1000/\sqrt{2}$ (d) $1000\sqrt{2}$

[1989 : 2 Marks]

1.2 When the annual demand of a product is 24000 units, the EOQ (Economic Order Quantity) is 2000 units. If the annual demand is 48000 units the most appropriate EOQ will be

- (a) 1000 units (b) 2000 units
(c) 2800 units (d) 4000 units

[1991 : 2 Marks]



Answers Inventory Control & Break-Even Analysis

1.1 (d) 1.2 (c)

Explanations Inventory Control & Break-Even Analysis

1.1 (d)

Economic order quantity,

$$EOQ = \sqrt{\frac{2DC_o}{C_h}}$$

Given that $EOQ = 1000$ units
When demand is doubled,

$$\begin{aligned} EOQ' &= \sqrt{\frac{2(2D)C_o}{C_h}} = \sqrt{2} \sqrt{\frac{2DC_o}{C_h}} \\ &= \sqrt{2} EOQ = 1000\sqrt{2} \end{aligned}$$



POINTS TO REMEMBER

- Here, $EOQ' = \sqrt{2} EOQ$ is taken because demand is increasing twicely to the previous demand.
- This problem is based on same formula as problem 2.1



1.2 (c)

Given that:

Annual demand, $D = 24000$ units

Economic order quantity, $EOQ = 2000$ units

Annual demand increases to 48000,

then, $D' = 48000 = 2 \times 24000 = 2D$

Economic order quantity when demand is 48000,

$$\begin{aligned} EOQ' &= \sqrt{2} EOQ = \sqrt{2} \times 2000 \\ &= 2828.427 \text{ units} \approx 2800 \text{ unit} \end{aligned}$$

- 2.1 In the construction of networks, dummy activities are introduced in order to
- (a) Compute the slack on all events
 - (b) Transfer resources, if necessary, during monitoring
 - (c) Clearly designate a precedence relationship
 - (d) Simplify the crashing plan

[1990 : 2 Marks]

■ ■ ■ ■

Answers PERT and CPM

2.1 (c)

Explanations PERT and CPM

2.1 (c)

Dummy Activity: An activity which only shows the dependency of one activity over other, but doesn't consume any time or resources. Dummy activity is introduced to clearly designate a precedence relationship.

■ ■ ■ ■