

GATE

Electrical Engineering

(Previous Years Solved Papers 1991-1994)

Contents

1. Electric Circuits	1 - 10
2. Signals and Systems	11 - 13
3. Electrical Machines	14 - 21
4. Power Systems	22 - 30
5. Control Systems	31 - 40
6. Electrical & Electronic Measurements	41 - 46
7. Analog Electronics	47 - 53
8. Digital Electronics	54 - 56
9. Power Electronics	57 - 62
10. Electromagnetic Theory	63 - 65
11. Engineering Mathematics	66 - 67



Electric Circuits

UNIT

I

CONTENTS

1. Basics 2
2. Steady State AC Analysis 3
3. Resonance and Locus Diagrams 4
4. Network Theorems 5
5. Transients and Steady State Response 6
6. Two Port Network and Network Functions 7
7. Magnetically Coupled Circuits,
Network Topology/Graph Theory & Filters 8
8. Three-Phase Circuits 9

1.1 All resistances in the figure are $1\ \Omega$ each. The value of current ' I ' is

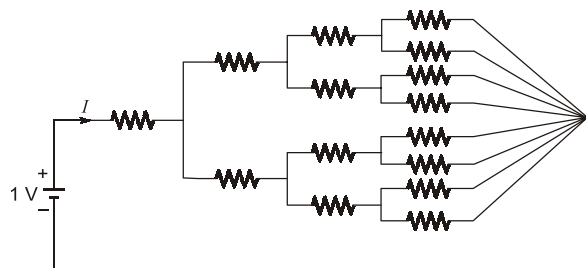

- (a) $\frac{1}{15}\text{ A}$
- (b) $\frac{2}{15}\text{ A}$
- (c) $\frac{4}{15}\text{ A}$
- (d) $\frac{8}{15}\text{ A}$

[1992 : 1 Mark]

1.2 All resistances in the circuit in figure are of R ohms each. The switch is initially open. What happens to the lamp's intensity when the switch is closed?

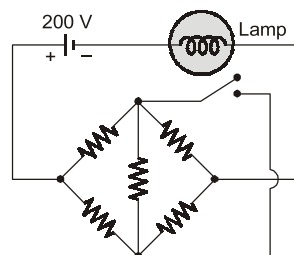

- (a) Increases
- (b) Decreases
- (c) Remains same
- (d) Answer depends on the value of R

[1992 : 1 Mark]

Answers Basics

1.1 (d) 1.2 (c)

Explanations Basics

1.1 (d)

$$R = 1 + [(1 \parallel 1 + 1) \parallel (1 \parallel 1 + 1) + 1]$$

$$= \frac{15}{8}\ \Omega \Rightarrow I = \frac{V}{R} = \frac{1}{15/8} = \frac{8}{15}\text{ A}$$

1.2 (c)

As the given bridge is balanced Wheatstone bridge, current flowing through the lamp will remain same irrespective of the state of switch; Hence intensity of lamp will remain same.



2

Steady State AC Analysis

- 2.1 In the circuit shown in figure, the voltage V_L has a phase angle of _____ with respect to V_s .

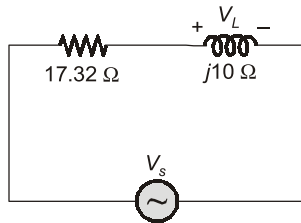

[1994 : 2 Marks]

Answers Steady State AC Analysis

2.1 (60)

Explanations Steady State AC Analysis

2.1 Sol.

$$V_L = V_s \times \frac{j10}{17.32 + j10}$$

(Using voltage division rule)

$$= V_s \times 0.5 \angle 60^\circ \text{ volts}$$

Hence, V_L has a phase angle of 60° with respect to V_s .



- 3.1 The following circuit shown in the figure resonates at

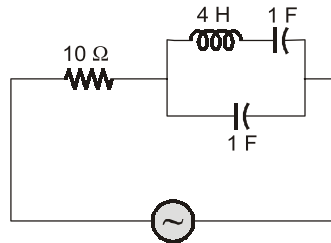

- (a) all frequencies (b) 0.5 rad/sec
(c) 5 rad/sec (d) 1 rad/sec

[1993 : 1 Mark]

- 3.2 At resonance, the given parallel circuit constituted by an iron-cored coil and a capacitor behaves like

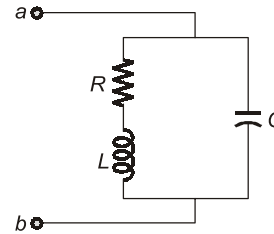

- (a) an open-circuit
(b) a short-circuit
(c) a pure resistor of value R
(d) a pure resistor of value much higher than R

[1994 : 1 Mark]

■■■■

Answers Resonance and Locus Diagrams

- 3.1 (b) 3.2 (d)

Explanations Resonance and Locus Diagrams

3.1 (b)

$$Z = 10 + \left(j4\omega - \frac{j}{\omega} \right) \parallel \left(-\frac{j}{\omega} \right)$$

$$= 10 - j \left[\frac{4 - \frac{1}{\omega^2}}{4\omega - \frac{2}{\omega}} \right]$$

For circuit to be in resonance imaginary part of Z must be equal to zero.

$$\text{Hence, } 4 - \frac{1}{\omega_{res}^2} = 0$$

$$\Rightarrow \omega_{res} = 0.5 \text{ rad/sec.}$$

3.2 (d)

$$Y = \frac{1}{R + j\omega L} \times \frac{R - j\omega L}{R - j\omega L} + \frac{1}{-jX_C}$$

$$Y = \frac{R - j\omega L}{R^2 + (\omega L)^2} + \frac{j}{X_C}$$

Imaginary parts are equal to zero for resonance

$$\frac{\omega L}{R^2 + (\omega L)^2} = \omega C$$

From this we get ' ω_0 '

At resonance,

$$Y = \frac{R}{R^2 + \omega_0^2 L^2} = \frac{1}{Y} = \frac{R^2 + \omega_0^2 L^2}{R}$$

$$Z \gg R$$

■■■■

4.1 In the following circuit, $i(t)$ under steady state is

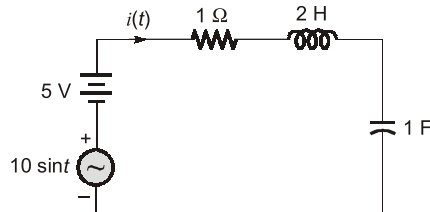

- (a) zero (b) 5
 (c) $7.07 \sin t$ (d) $7.07 \sin(t - 45^\circ)$

[1993 : 1 Mark]

4.2 Superposition principle is not applicable to a network containing time-varying resistors. (True/False).

[1994 : 1 Mark]

■■■■

Answers Network Theorems

4.1 (d) 4.2 (F)

Explanations Network Theorems

4.1 (d)

For DC supply of 5 V, the capacitor acts as open circuit at the steady state, consequently there will not be any current flowing in the circuit due to DC supply.

For AC supply of $V = 10 \sin(t)$; $\omega = 1$ rad/sec.

$$\begin{aligned} Z &= R + j\omega L - \frac{j}{\omega C} = 1 + j2 - j \\ &= (1 + j) = \sqrt{2} \angle 45^\circ \Omega \end{aligned}$$

$$\begin{aligned} \text{Hence, Current, } I &= \frac{V}{Z} \\ &= \frac{10 \sin(t)}{\sqrt{2} \angle 45^\circ} = 7.07 \sin(t - 45^\circ) \text{ A} \end{aligned}$$

4.2 Sol.

False. Superposition principle is applicable on both time variant and time invariant resistors.

■■■■

5

Transients and Steady State Response

5.1 The time constant of the network shown in the figure is

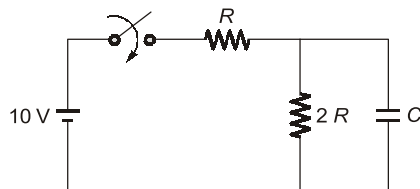

- (a) $2RC$ (b) $3RC$
 (c) $\frac{RC}{2}$ (d) $\frac{2RC}{3}$

[1992 : 1 Mark]

Answers Transients and Steady State Response

5.1 (d)

Explanations Transients and Steady State Response

5.1 (d)

Time constant, $\tau = R_{\text{net}} \cdot C$

R_{net} = Net resistance across capacitor when all the independent voltage sources are short circuited and all independent current sources are open circuited.

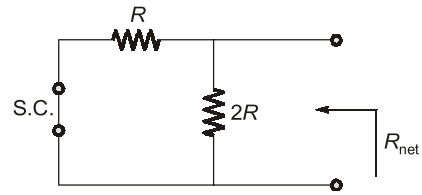

$$R_{\text{net}} = R \parallel 2R = \frac{2}{3}R$$

Hence time constant,

$$\tau = \frac{2}{3}RC \text{ sec.}$$



6

Two Port Network and Network Functions

6.1 If a two-port network is reciprocal, then we have, with the usual notation, the following relationship

- (a) $h_{12} = h_{21}$
- (b) $h_{12} = -h_{21}$
- (c) $h_{11} = h_{22}$
- (d) $h_{11} h_{22} - h_{12} h_{21} = 1$

[1994 : 1 Mark]

Answers Two Port Network and Network

6.1 (b)

Explanations Two Port Network and Network

6.1 (b)

For reciprocity,

$$h_{12} = -h_{21}$$

For symmetry, $\begin{vmatrix} h_{11} & h_{12} \\ h_{21} & h_{22} \end{vmatrix} = 1$



Magnetically Coupled Circuits, Network Topology/Graph Theory & Filters

7.1 The equivalent inductance seen at terminals A–B in the figure is H.

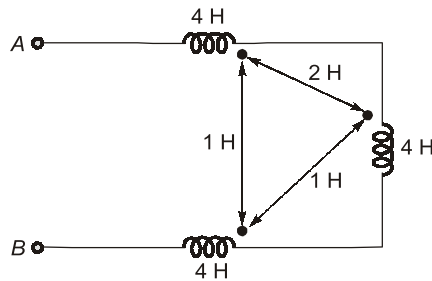

[1992 : 2 Marks]

7.2 The figure shows a DC resistive network and its graph is drawn a side. A 'proper tree' chosen for analysing the network will not contain the edges:

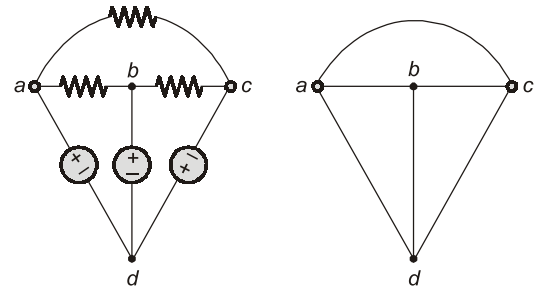

- (a) ab, bc, ad
- (b) ab, bc, ca
- (c) ab, bd, cd
- (d) ac, bd, ad

[1994 : 1 Mark]

Answers Magnetically Coupled Circuits, Network Topology/Graph Theory & Filters

7.1 (8) 7.2 (b)

Explanations Magnetically Coupled Circuits, Network Topology/Graph Theory & Filters

7.1 Sol.

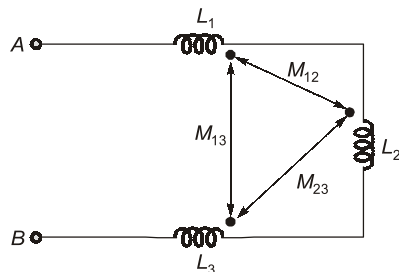

$$\begin{aligned}
 L &= L_1 + L_2 + L_3 - 2 M_{12} + 2 M_{23} - 2 M_{13} \\
 &= 4 + 4 + 4 - (2 \times 2) + (2 \times 1) - (2 \times 1) \\
 &= 8 \text{ H}
 \end{aligned}$$

7.2 (b)

Tree must not contain any closed loop. Hence, option (b) is correct.



8.1 Using Thevenin equivalent circuit, determine the RMS value of the voltage across the 100 ohm resistor after the switch is closed in the 3-phase circuit shown in the figure.

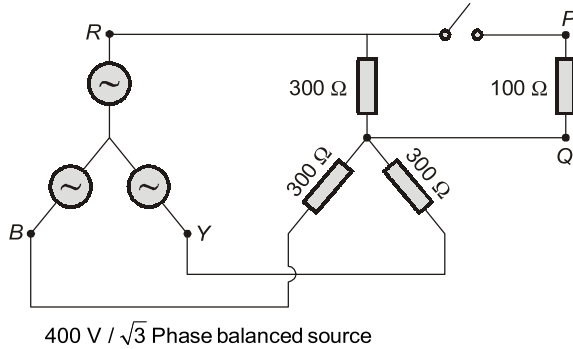

[1992 : 2 Marks]

8.2 A set of 3 equal resistors, each of value R_x , connected in star across RYB of given figure consumes the same power as the unbalanced delta connected load shown. The value of R_x is

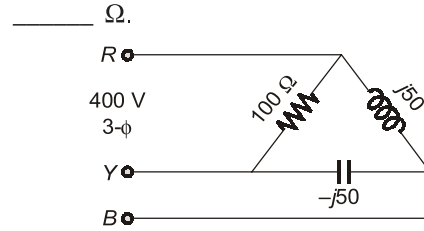

[1994 : 2 Marks]

Answers Three-Phase Circuits

8.1 (115.5) 8.2 (100)

Explanations Three-Phase Circuits

8.1 Sol.

$$V_{Th} = V_{ph} = \frac{400}{\sqrt{3}} \simeq 231V$$

Now, to find Z_{Th} , replacing all the independent voltage sources by short circuit, We have,

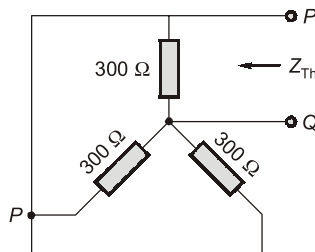

$$\therefore Z_{Th} = 300 \parallel 300 \parallel 300 = 100 \Omega$$

\therefore Thevenin's equivalent circuit:

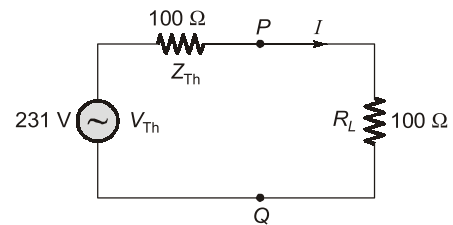

\therefore Voltage across 100 Ω resistor

$$= 231 \times \frac{100}{100 + 100} \quad (\text{voltage division rule})$$

$$= \frac{231}{2} = 115.5 V$$

8.2 Sol.

∴ Only resistor consumes power, neither inductor nor capacitor.

∴ Power consumed in unbalanced delta

$$\text{connected load} = \frac{V_{ph}^2}{R} = \frac{V_L^2}{R} = \frac{(400)^2}{100} = 1600 \text{ W}$$

Power consumed in a balanced star connection containing a set of equal resistors (in all three phases), each of value

$$R_x = 3 \left[\frac{V_{ph}^2}{R_x} \right] = \frac{V_L^2}{R_x} = \frac{(400)^2}{R}$$

∴ According to the question, power consumed in both the cases is equal.

$$\therefore 1600 = \frac{(400)^2}{R} \Rightarrow R = 100 \Omega$$



Signals and Systems

UNIT

II

CONTENTS

1. Introduction of C.T. and D.T. Signals 12
2. Linear Time Invariant Systems 13

1

Introduction of C.T. and D.T. Signals

1.1 The value of the integral $\int_{-5}^{+6} e^{-2t} \delta(t-1) dt$ is equal to _____.

[1994 : 1 Mark]

Answers Introduction of C.T. and D.T. Signals

1.1 (Sol.)

Explanations Introduction of C.T. and D.T. Signals

1.1 Sol.

Using, $\int_{-\infty}^{\infty} x(t) \delta(t-t_0) dt = x(t_0)$

We have, $\int_{-5}^{6} e^{-2t} \delta(t-1) dt = e^{-2}$

■■■■

2.1 $s(t)$ is step response and $h(t)$ is impulse response of a system. Its response $y(t)$ for any input $u(t)$ is given by

(a) $\frac{d}{dt} \int_0^t s(t-\tau) u(\tau) d\tau$

(b) $\int_0^t s(t-\tau) u(\tau) d\tau$

(c) $\int_0^t \int_0^{\tau} s(t-\tau) u(\tau_1) d\tau_1 d\tau$

(d) $\frac{d}{dt} \int_0^t h(t-\tau) u(\tau) d\tau$

[1993 : 1 Mark]

2.2 If $f(t)$ is the step-response of a linear time-invariant system, then its impulse response is given by _____.

[1994 : 1 Mark]

Answers Linear Time Invariant Systems

2.1 (a) 2.2 (Sol.)

Explanations Linear Time Invariant Systems

2.1 (a)

$y(t) = u(t) * h(t)$ (always)
 where $h(t)$ is impulse response
 $\therefore s(t)$ is step response (given)

$$\Rightarrow \frac{d}{dt} s(t) = h(t)$$

$$\therefore y(t) = u(t) * \frac{d}{dt} s(t)$$

$$= \frac{d}{dt} [u(t) * s(t)] \quad (\text{using property})$$

$$= \frac{d}{dt} \int_{-\infty}^{\infty} u(\tau) s(t-\tau) d\tau$$

(by definition of convolution)

$$= \frac{d}{dt} \int_0^t u(\tau) s(t-\tau) d\tau$$

($\because u(t)$ and $s(t)$ are causal functions)

2.2 Sol.

$$h(t) = \frac{d}{dt} f(t)$$

■■■■

Electrical Machines

UNIT III

CONTENTS

1. D.C. Machines 15
2. Transformers 16
3. Three Phase Induction Machines 18
4. Synchronous Machines 19
5. Single Phase Induction Motors, Special Purpose Machines and Electromechanical Energy Conversion Systems 21

1.1 A separately excited DC motor has an armature resistance of 0.5 ohms. It runs from a 250 V DC supply drawing an armature current of 20 A at 1500 rpm. For the same field current, the torque developed for an armature current of 10 A will be _____.

[1992 : 1 Mark]

1.2 Neglecting all losses, the developed torque (T) of a DC separately excited motor, operating under constant terminal voltage, is related to its output power (P) as under

- (a) $T \propto \sqrt{P}$ (b) $T \propto P$
 (c) $T^2 \propto P^3$ (d) T independent of P

[1992 : 1 Mark]

1.3 A cumulative compound long shunt motor is driving a load at rated torque and rated speed. If the series field is shunted by a resistance equal to the resistance of the series field, keeping the torque constant

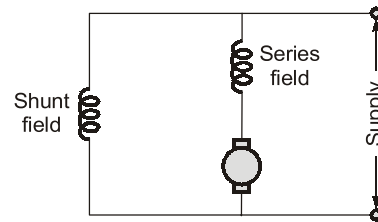

- (a) the armature current increases
 (b) the motor speed increases
 (c) the armature current decreases
 (d) the motor speed decreases

[1993 : 1 Mark]

Answers D.C. Machines

1.1 (15.2788) 1.2 (b) 1.3 (a)

Explanations D.C. Machines

1.1 Sol.

$$\begin{aligned} V &= E_b + I_a R_a \\ 250 &= E_b + 20 \times 0.5 \\ E_b &= 240 \text{ V} \\ T &= \frac{P}{\omega} = \frac{E_b I_a}{\frac{2\pi N}{60}} = \frac{240 \times 10 \times 60}{2\pi \times 1500} \\ &= 15.2788 \text{ Nm} \end{aligned}$$

1.2 (b)

$$\begin{aligned} T &= K\phi I_a \\ T &\propto I_a \quad \dots(i) \\ P &= E_b I_a \end{aligned}$$

For constant voltage supply, $P \propto I_a$... (ii)

From (i) and (ii) $T \propto P$.

1.3 (a)

$$T = K\phi I_a$$

The value of current in series field gets halved. Hence, the armature current is to be increased in order to have fixed torque.



- 2.1** Two transformers of the same type, using the same grade of iron and conductor materials, are designed to work at the same flux and current densities; but the linear dimensions of one are two times those of the other in all respects. The ratio kVA of the two transformers closely equals
 (a) 16 (b) 8
 (c) 4 (d) 2
[1992 : 1 Mark]
- 2.2** Two transformers of different kVA ratings working in parallel share the load in proportional to their ratings when their
 (a) per unit leakage impedances on the same kVA base are the same.
 (b) per unit leakage impedances on their respective ratings are equal.
 (c) ohmic values of the leakage impedances are inversely proportional to their ratings.
 (d) ohmic values of the leakage magnetizing reactances are the same.
[1992 : 1 Mark]
- 2.3** A Buchholz relay is used for
 (a) protection of a transformer against all internal faults.
 (b) protection of a transformer against external faults.
 (c) protection of a transformer against both internal and external faults.
 (d) protection of induction motors.
[1992 : 1 Mark]
- 2.4** A 50 Hz, 220/400 V, 50 kVA single-phase transformer operates on 220 V, 40 Hz supply with secondary winding. Then
 (a) the eddy current loss and hysteresis loss of the transformer decrease
 (b) the eddy current loss and hysteresis loss of the transformer increase
 (c) the hysteresis loss of the transformer increase while eddy current loss remains the same
 (d) the hysteresis loss remains the same whereas eddy current loss decreases
[1993 : 2 Marks]
- 2.5** When a transformer winding suffers a short-circuit, the adjoining turns of the same winding experience
 (a) an attractive force
 (b) a repulsive force
 (c) no force
 (d) none of the above
[1994 : 1 Mark]
- 2.6** Two transformers of identical voltage but of different capacities are operating in parallel. For satisfactory load sharing
 (a) impedances must be equal
 (b) per unit impedances must be equal
 (c) per unit impedances and X/R ratios must be equal
 (d) impedances and X/R ratios must be equal
[1994 : 1 Mark]

Answers Transformers

2.1 (a) 2.2 (b, c) 2.3 (a) 2.4 (c) 2.5 (a) 2.6 (b)

Explanations Transformers**2.1 (a)**

Both the developed emf and current carrying capability are the functions of core area.

Current carrying capabilities or the current density of the core material is fixed. As the area has increased '4' times, current carrying capability has also increased '4' times.

The induced emf is directly proportional to core area. Hence it has also increased '4' times.

$$kVA_2 = E_2 I_2 = 4 E_1 \times 4 I_1 = 16 E_1 I_1$$

2.3 (a)

It is used to detect incipient faults.

2.4 (c)

$$W_h \propto B_m^{1.6} f$$

$$W_h \propto \frac{B_m^{1.6} f^{1.6}}{f^{0.6}} \propto \frac{V^{1.6}}{(f)^{0.6}} \quad (\text{As } V \propto B_m f)$$

$$W_e \propto B_m^2 f^2 \propto V^2$$

2.5 (a)

Since the direction of current in adjoining turns is same, it will feel force of attraction.

2.6 (b)

For satisfactory load sharing of two transformer the per unit impedances must be equal.



3.1 A three-phase slip ring induction motor is fed from the rotor side with stator winding short-circuited. The frequency of the currents flowing in the short-circuited stator winding will be

- (a) slip frequency
- (b) supply frequency
- (c) frequency corresponding to rotor speed
- (d) zero

[1993 : 1 Mark]

3.2 Skewing is used in induction motors in order to reduce torque due to

- (a) time harmonics (b) space harmonics
- (c) slot harmonics (d) reverse rotating fields

[1994 : 1 Mark]

3.3 A 3-phase induction motor coupled to a pump is operating at normal speed. If one line gets disconnected, the motor stops. (State whether true or false).

[1994 : 1 Mark]

3.4 A six pole 50 Hz induction motor rotating at 1400 rpm is in _____ mode.

[1994 : 1 Mark]

3.5 In a variable frequency induction motor drive, the voltage must be varied _____ to the frequency.

[1994 : 1 Mark]

Answers Three Phase Induction Machines

3.1 (a) **3.2** (c) **3.3** (Sol.) **3.4** (Sol.) **3.5** (Sol.)

Explanations Three Phase Induction Machines

3.3 Sol.

(False)

Single phasing will occur but the motor will continue to run with reduced capacity.

3.4 Sol.

$$N_s = \frac{120 \times 50}{6} = 1000 \text{ rpm}$$

$$N > N_s$$

Super synchronous mode or working as an induction generator.

3.5 Sol.

Linearly,

In order to have fixed value of air gap-flux, the ratio (V/f) must be kept constant.

$$\Rightarrow \frac{V}{f} = K$$

$$V = Kf$$

It is directly proportional to the frequency.



- 4.1 The torque angle of a synchronous machine operating from a constant voltage bus, is usually defined as the space angle between
- Rotor mmf wave and stator mmf wave
 - Rotor mmf wave and resultant flux density wave
 - Stator mmf wave and resultant flux density wave
 - Stator mmf wave and resultant mmf wave

[1992 : 1 Mark]

- 4.2 The figure, depicts the load characteristics of an isolated three-phase alternator, running at constant speed. Match the following sets of operating conditions with the given characteristics. Disregard the effects of saliency, saturation and stator resistance.

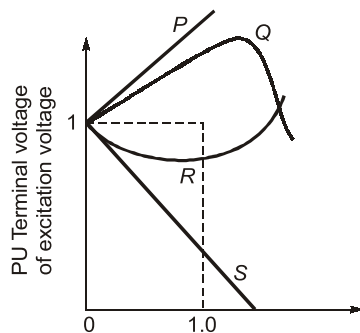

- Constant excitation and non-zero leading power-factor.
- Constant excitation and zero power-factor, leading.
- Constant terminal voltage and zero power-factor, leading.
- Constant terminal voltage and non-zero leading power-factor.

[1992 : 2 Marks]

- 4.3 A three-phase alternator has negligible stator resistance. A short-circuit test is conducted on this alternator. At a particular speed a field current of I_f is required to drive the rated armature current. If the speed of the alternator is reduced to half, the field current required to maintain rated armature current

- would be equal to I_f
- would be equal to $2 I_f$
- would be equal to $I_f/2$
- cannot be predicted due to insufficient data

[1993 : 2 Marks]

- 4.4 A synchronous motor operates at 0.8 p.f. lagging. If the field current of the motor is continuously increased
- the power factor decreases upto a certain value of field current and thereafter it increases.
 - the armature current increases upto a certain value of field current and thereafter it decreases.
 - the power factor increases upto a certain value of field current and thereafter it decreases.
 - the armature current decreases upto a certain value of field current and thereafter it increases.

From these the correct one is

- 1 and 2
- 2 and 3
- 3 and 4
- 1 and 3

[1993 : 2 Marks]

- 4.5 Two 550 kVA alternators operate in parallel to supply the following loads
- 250 kW at 0.95 power factor lag
 - 100 kW at 0.8 power factor lead
- One machine is supplying 200 kW at 0.9 power factor lag. The power factor of the other machine must be
- 0.89 lead
 - 0.95 lead
 - 0.95 lag
 - 0.89 lag

[1993 : 2 Marks]



Answers Synchronous Machines

4.1 (a) 4.2 (Sol.) 4.3 (a) 4.4 (c) 4.5 (a)

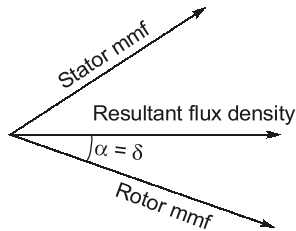
Explanations Synchronous Machines**4.1 (a)****4.2 Sol.**

a - Q, b - P, c - S, d - R.

4.3 (a)

For short circuit calculation,

$$I_{sc} = \frac{E_t}{Z_s} \approx \frac{E_t}{X_s}$$

Also $E_t \propto f\phi$ and $X_s \propto f$ which gives $I_{sc} \propto \phi$

Hence short circuit current is only a function of excitation.

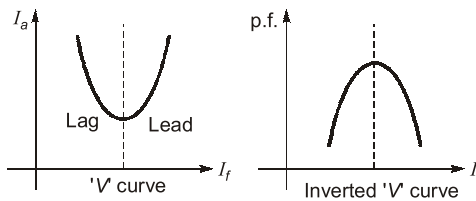
4.4 (c)**4.5 (a)**

Total kVA supplied to load

$$= \frac{250}{0.95} \angle -\cos^{-1}(0.95)$$

$$= (250 - j82.17) \text{ kVA}$$

Total kVA supplied by M_2

$$= \frac{100}{0.8} \angle \cos^{-1}(0.8)$$

$$= 100 + j75$$

Total kVA supplied by M_1

$$= \frac{200}{0.9} \angle -\cos^{-1}(0.9)$$

$$= (200 - j96.864) \text{ kVA}$$

Using power conservation,

$$(250 - j82.17) + (100 + j75)$$

$$= (200 - j96.864) + S_2$$

$$\Rightarrow S_2 = 174.65 \angle +30.814^\circ$$

Positive signs indicates leading pf.

$$\text{p.f.} = \cos(30.814^\circ)$$

$$= 0.8588 \text{ lead.}$$

■■■■

Single Phase Induction Motors, Special Purpose Machines and Electromechanical Energy Conversion Systems

- 5.1 The developed electromagnetic force and/or torque in electro-mechanical energy conversion systems act in a direction that tends
- (a) to increase the stored energy at constant mmf
 - (b) to decrease the stored energy at constant flux
 - (c) to decrease the co-energy at constant mmf
 - (d) to increase the stored energy at constant mmf

[1992 : 1 Mark]

Answers

Single Phase Induction Motors, Special Purpose Machines and Electromechanical Energy Conversion Systems

- 5.1 (b)

Explanations

Single Phase Induction Motors, Special Purpose Machines and Electromechanical Energy Conversion Systems

- 5.1 (b)

Lenz law.



CONTENTS

1. Performance of Transmission Lines,
Line Parameters & Corona 241
2. Compensation Techniques and
Voltage Profile Control 251
3. Distribution Systems, Cables
and Insulators 258
4. Economic Power Generation and
Load Dispatch 264
5. Fault Analysis 271
6. Power System Stability 291
7. Switch Gear and Protection 307
8. Generating Power Stations 312
9. Load Flow Studies 313
10. High Voltage DC Transmission 326
11. Per Unit System 328
12. Power System Transients 330

Performance of Transmission Lines, Line Parameters and Corona

- 1.1 The inductance of a power transmission line increases with
- decrease in line length.
 - increase in diameter of conductor.
 - increase in spacing between the phase conductors.
 - increase in load current carried by the conductors.

[1992 : 1 Mark]

- 1.2 A three phase overhead transmission line has its conductors horizontally spaced with spacing between adjacent conductors equal to 'd'. If now the conductors of the line are rearranged to form an equilateral triangle of sides equal to 'd' then
- average capacitance and inductance will increase.

- average capacitance will increase and inductance will increase.
- average capacitance will increase and inductance will decrease.
- surge impedance loading of the line increases.

[1993 : 1 Mark]

- 1.3 The increase in resistance due to non-uniform distribution of current in a conductor is known as _____ effect.

[1994 : 1 Mark]

- 1.4 The charging current of a 400 kV transmission line is more than that of a 220 kV line of the same length. [True/False]

[1994 : 2 Marks]

Answers Performance of Transmission Lines, Line Parameters and Corona

1.1 (c) 1.2 (c) 1.3 (Sol.) 1.4 (T)

Explanations Performance of Transmission Lines, Line Parameters and Corona

1.1 (c)

$$L \propto \ln\left(\frac{d}{r'}\right)$$

$$\Rightarrow L \propto d \quad \text{and} \quad L \propto \frac{1}{r'}$$

1.2 (c)

$$L \propto \text{GMD}$$

$$C \propto \frac{1}{\text{GMD}}$$

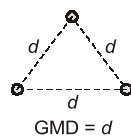
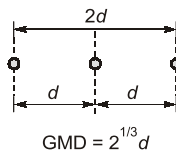

1.3 Sol.

The increase in resistance due to non-uniform distribution of current in a conductor is known as **skin effect**.

1.4 Sol.

$$I_C = 2\pi f V_{ph} C_{ph}$$

$$I_C \propto V_{ph}$$

∴ True



2

Compensation Techniques and Voltage Profile Control

2.1 In a 400 kV network, 360 kV is recorded at a 400 kV bus. The reactive power absorbed by a shunt reactor rated for 50 MVAR, 400 kV connected at the bus is

- (a) 61.73 MVAR (b) 55.56 MVAR
(c) 45 MVAR (d) 40.5 MVAR

[1994 : 1 Mark]

Answers Compensation Techniques and Voltage Profile Control

2.1 (d)

Explanations Compensation Techniques and Voltage Profile Control

2.1 (d)

Reactive power absorbed,

$$Q_{\text{absorbed}} = \frac{V^2}{X_{\text{rated}}} = \frac{(360)^2}{(400)^2 / 50} = 40.5 \text{ MVAR}$$



3

Distribution Systems, Cables and Insulators

- 3.1 The selection of size of conductors for a distributor in a distribution system is governed by
- (a) Corona loss
 - (b) Temperature rise
 - (c) Radio interference
 - (d) Voltage drop

[1992 : 1 Mark]

Answers Distribution Systems, Cables and Insulators

- 3.1 (d)

4.1 In a power-system, the 3-phase fault MVA is always higher than the single-line-ground fault MVA at a bus. (True/False).

[1994 : 1 Mark]

Answers Fault Analysis

4.1 (F)

Explanations Fault Analysis

4.1 Sol.

False. For a line to ground fault, the fault current is highest as compared to other fault conditions, given the same value of fault conditions.



5.1 The transient stability of the power system can be effectively improved by

- (a) improving generator excitation
- (b) phase shifting transformer
- (c) single pole switching of circuit breakers
- (d) increasing the turbine valve opening

[1993 : 1 Mark]

5.2 In a system, there are two generators operating in parallel. One generator, of rating 250 MVA, has an inertia constant of 6 MJ/MVA while the other generator of 150 MVA has an inertia constant of 4 MJ/MVA. The inertia constant for the combined system on 100 MVA common base is MJ/MVA.

[1994 : 2 Marks]

Answers Power System Stability

5.1 (c) 5.2 (21)

Explanations Power System Stability

5.1 (c)

Using high speed circuit breakers, this can be achieved.

5.2 Sol.

For 250 MVA generator

$$H = \frac{250}{100} \times 6 = 15 \text{ MJ/MVA}$$

For 150 MVA generator

$$H = 4 \times \frac{150}{100} = 6 \text{ MJ/MVA}$$

$$H = 15 + 6 = 21 \text{ MJ/MVA}$$



- 6.1 The distribution system shown in the figure is to be protected by over current system of protection. For proper fault discrimination directional over current relays will be required at locations

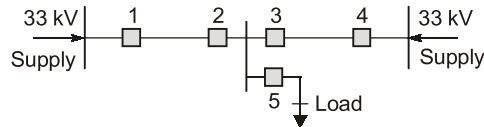

- (a) 1 and 4 (b) 2 and 3
 (c) 1, 4 and 5 (d) 2, 3 and 5

[1993 : 2 Marks]

Answers Switch Gear and Protection

6.1 (b)

Explanations Switch Gear and Protection

6.1 (b)

If a fault occurs in between relay 1 and 2, the direction of current in relay '2' changes. Similarly if a fault occurs between relay 3 and 4 the direction of current in relay '3' changes.

Hence these relays '2' and '3' must be directional in nature.



7.1 In load flow studies of a power system, the quantities specified at a voltage controlled bus are _____ and _____.

[1992 : 1 Mark]

7.2 In load flow analysis, the load connected at a bus is represented as

- (a) constant current drawn from the bus
- (b) constant impedance connected at the bus
- (c) voltage and frequency dependent source at the bus
- (d) constant real and reactive power drawn from the bus

[1993 : 1 Mark]

Answers Load Flow Studies

7.1 (Sol.) 7.2 (d)

Explanations Load Flow Studies

7.1 Sol.

In load flow studies of a power system, the quantities specified at a voltage controlled bus are $|V|$ and P .

7.2 (d)

In load flow study generators are modeled as source of complex power, loads are modeled as demand of complex power and transmission lines are modeled as π -model.



- 8.1 HVDC transmission is preferred to EHV – AC because
- (a) HVDC terminal equipment are inexpensive
 - (b) VAR compensation is not required in HVDC systems
 - (c) System stability can be improved
 - (d) Harmonics – problem is avoided

[1994 : 1 Mark]

Answers High Voltage DC Transmission

- 8.1 (c)

Control Systems

UNIT

V

CONTENTS

1. Mathematical Models of
Physical Systems 32
2. Time Response Analysis 33
3. Concepts of Stability 34
4. Root Locus Techniques 35
5. Frequency Response Analysis 37
6. Design of Control Systems 39
7. State Variable Analysis 40

Mathematical Models of Physical Systems

1.1 The signal flow graph of figure shown below, has _____ forward paths and _____ feedback loops.

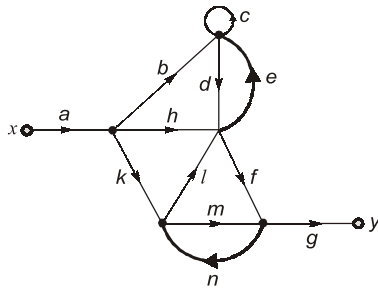

[1991 : 2 Marks]

1.2 The overall transfer function of the system shown in figure is

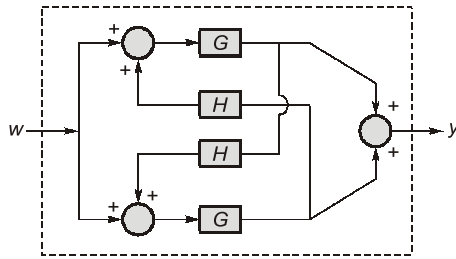

Answers Mathematical Models of Physical Systems

1.1 (4, 4) 1.2 (b) 1.3 (b)

Explanations Mathematical Models of Physical Systems

1.1 (4, 4)

Number of forward paths
= 4 (*abdfg, ahfg, akldfg, akmg*)
Number of loops = 4 (*c, de, lfn, mn*)

1.2 (b)

SFG:

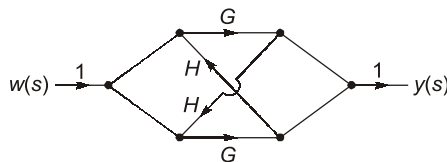

(a) $\frac{G}{1-GH}$ (b) $\frac{2G}{1-GH}$

(c) $\frac{GH}{1-GH}$ (d) $\frac{GH}{1-H}$

[1992 : 1 Mark]

1.3 Signal flow graph is used to obtain the

- (a) stability of a system
- (b) transfer function of a system
- (c) controllability of a system
- (d) observability of a system

[1993 : 1 Mark]

$$\therefore \text{T.F.} = \frac{G + GHG + G + GHG}{1 - [GHGH]} = \frac{2G(1 + GH)}{1 - G^2H^2}$$

[4 forward paths are there]

$$= \frac{2G}{1 - GH}$$

1.3 (b)

Signal flow graph is used to find the transfer function between the output and input node.



2

Time Response Analysis

2.1 A first order system and its response to a unit step input are shown in the figure below. The system parameters are

$a = \underline{\hspace{2cm}}$
 $K = \underline{\hspace{2cm}}$

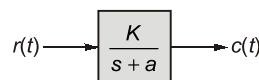
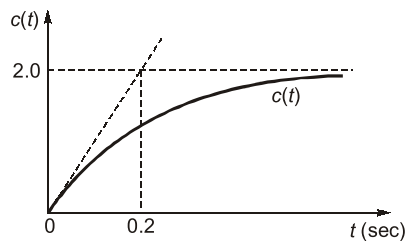

[1991 : 2 Marks]

2.2 For what values of 'a' does the system shown in figure have a zero steady state error [i.e. $\lim_{t \rightarrow \infty} E(t)$] for a step input?

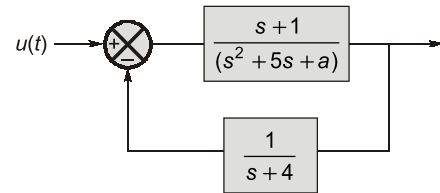

- (a) $a = 0$ (b) $a = 2$
 (c) $a \geq 4$ (d) for no value of 'a'

[1992 : 1 Mark]

Answers Time Response Analysis

2.1 (5, 10) 2.2 (a)

Explanations Time Response Analysis

2.1 (5, 10)

\therefore Time constant = 0.2 sec. (from figure)

$$= \frac{1}{a} \quad \left(\text{From } G(s) = \frac{K}{a \left(1 + \frac{s}{a} \right)} \right)$$

$$\therefore \frac{1}{a} = 0.2$$

$$\Rightarrow a = 5$$

\therefore Final value = $\lim_{s \rightarrow 0} sC(s)$

$$= \lim_{s \rightarrow 0} s \frac{K}{s+a} \cdot \frac{1}{s} = \frac{K}{a} = 2 \quad (\text{from figure})$$

$$\therefore \frac{K}{a} = 2$$

$$\Rightarrow K = 2 \times 5 = 10$$

2.2 (a)

$$E(s) = \frac{R(s)}{1 + G(s)H(s)}$$

$$\lim_{t \rightarrow \infty} E(t) = \lim_{s \rightarrow 0} sE(s)$$

$$= \lim_{s \rightarrow 0} \frac{s \cdot \frac{1}{s}}{1 + \frac{(s+1)}{(s^2+5s+a)} \cdot \frac{1}{(s+4)}}$$

$$\Rightarrow \frac{1}{1 + \frac{1}{4a}} = 0$$

$$\Rightarrow \frac{4a}{4a+1} = 0$$

Hence, $a = 0$



- 3.1 The closed loop system of figure is stable if the transfer function $T(s) = \frac{C(s)}{R(s)}$ is stable. (True/False)

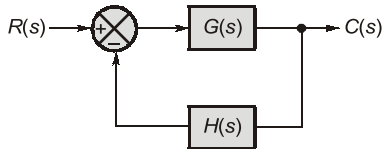

[1994 : 1 Mark]

- 3.2 The number of positive real roots of the equation $s^3 - 2s + 2 = 0$ is _____.

[1994 : 1 Mark]

Answers Concepts of Stability

3.1 (Sol.) 3.2 (Sol.)

Explanations Concepts of Stability

3.1 Sol.

All the close loop poles must lie in left half of the s-plane.

3.2 Sol.

$$\therefore s^3 - 2s + 2 = 0$$

$$\therefore s = -1.77, 0.88 \pm j0.59$$

Hence, no positive real root exists.



4

Root Locus Techniques

4.1 A unity feedback system has an open loop transfer function of the form $KG(s) = \frac{K(s+a)}{s^2(s+b)}$; $b > a$

which of the loci shown in the figure can be valid root-loci for the system?

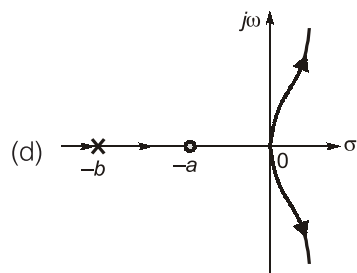
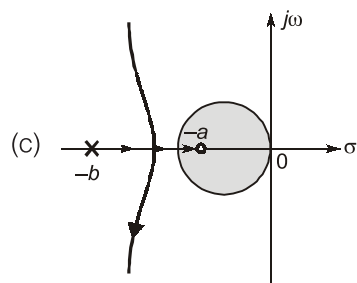
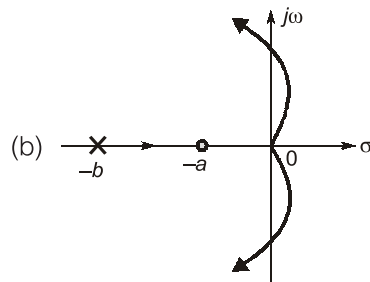
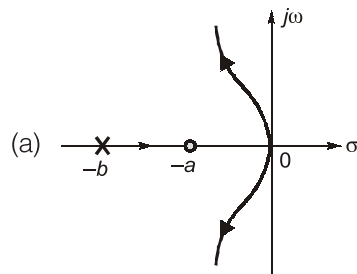

[1991 : 1 Mark]

4.2 Which of the following figure(s) represent valid root loci in the s-plane for positive K ? Assume that the system has transfer function with real coefficient.

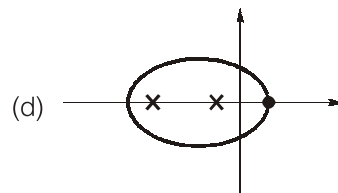
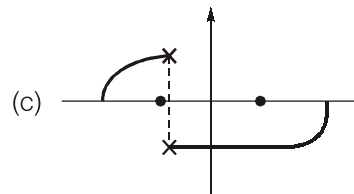
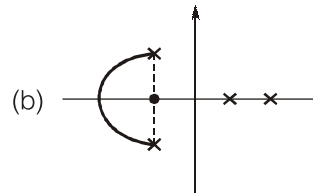
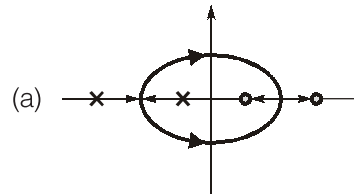

[1992 : 1 Mark]

Answers Root Locus Techniques

4.1 (a) 4.2 (a)

Explanations Root Locus Techniques**4.1** (a)

$$P = 3, \quad Z = 1$$

and two repeating poles at origin

$$\begin{aligned} \text{Centroid} &= \frac{0 - b - (-a)}{3 - 1} \\ &= \frac{-(b - a)}{2} < 0 \end{aligned}$$

$$\begin{aligned} \text{Angle of asymptotes} &= \frac{(2q + 1) 180^\circ}{3 - 1} \\ &= 90^\circ \quad (\text{for } q = 0) \\ &= 270^\circ \quad (\text{for } q = 1) \end{aligned}$$

∴ Option (a) is correct.

4.2 (a)

The valid root loci in the s-plane can be only option (a), because of symmetry and root locus definition.



5

Frequency Response Analysis

5.1 Which of the following is the transfer function of a system having the Nyquist plot shown in the figure below?

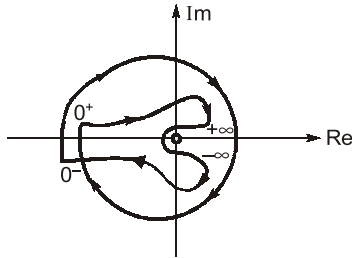

- (a) $\frac{K}{s(s+2)^2(s+5)}$ (b) $\frac{K}{s^2(s+2)(s+5)}$
 (c) $\frac{K(s+1)}{s^2(s+2)(s+5)}$ (d) $\frac{K(s+1)(s+3)}{s^2(s+2)(s+5)}$

[1991 : 1 Mark]

5.2 The system having the Bode magnitude plot shown in the figure below has the transfer function.

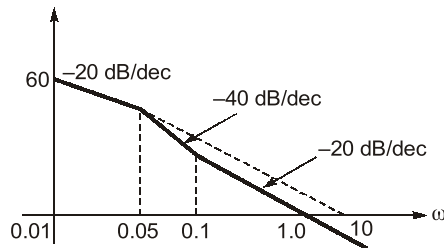

- (a) $\frac{60(s+0.01)(s+0.1)}{s^2(s+0.05)^2}$
 (b) $\frac{10(1+10s)}{s(1+20s)}$
 (c) $\frac{3(s+0.05)}{s(s+0.1)(s+1)}$
 (d) $\frac{5(s+0.1)}{s(s+0.05)}$

[1991 : 1 Mark]

5.3 A unity feedback system has the open loop transfer function,

$$G(s) = \frac{1}{(s-1)(s+2)(s+3)}$$

The Nyquist plot of $G(s)$ encircle the origin.

- (a) Never (b) Once
 (c) Twice (d) Thrice

[1992 : 1 Mark]



Answers **Frequency Response Analysis**

- 5.1 (b) 5.2 (b, d) 5.3 (a)

Explanations Frequency Response Analysis**5.1 (b)**

∴ Curve starts from $-180^\circ \Rightarrow$ type 2 system and
 ∴ Curve ends at -360° .
 \Rightarrow difference between number of poles and
 number of zeros = $\frac{360^\circ}{90^\circ} = 4$
 ∴ Only option (b) is satisfying these two
 properties, So, option (b) is correct.

5.2 (b, d)

Type = 1

Poles at $\Rightarrow \omega = 0, 0.05$ Zero at $\Rightarrow \omega = 0.1$

Using initial line equation,

$$\text{dB} = 20 \log K - 20 \log(\omega)$$

At $\omega = 0.01$

$$\text{dB} = 60$$

$$\therefore 60 = -20 \log(0.01) + 20 \log K$$

On solving, $K = 10$

Therefore,

$$\text{Transfer function} = \frac{10(1+10s)}{s(1+20s)} = \frac{5(s+0.1)}{s(s+0.05)}$$

5.3 (a)

$$G(s) = \frac{1}{(s-1)(s+2)(s+3)}$$

$$1 + G(s)H(s) = 0$$

$$\text{i.e., } s^3 + 4s^2 + s - 5 = 0$$

Applying Routh criteria

$$\begin{array}{l|ll} s^3 & 1 & 1 \\ s^2 & 4 & -5 \\ s^1 & 9/4 & 0 \\ s^0 & -5 & \end{array}$$

Hence, number of closed loop poles at RHS of
 s-plane = number of sign changes = One.

Number of encirclements of $G(s)$ about origin
 = Number of encirclements of $G(s)H(s)$ about
 $(-1, 0) = \{\text{Number of open loop poles at RHS of
 s-plane} - \text{Number of closed loop poles at RHS of
 s-plane}\}.$

$$N = P - Z = 1 - 1 = 0$$

∴ No encirclement of origin of $G(s)$.



6

Design of Control Systems

6.1 The pole zero configuration of a phase lead compensator is given by

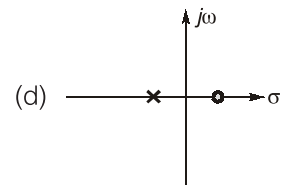
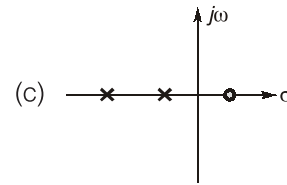
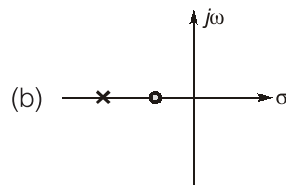
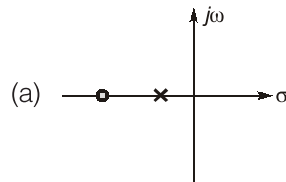

[1994 : 1 Mark]

Answers Design of Control Systems

6.1 (b)

Explanations Design of Control Systems

6.1 (b)

In phase lead compensator $|P| > |Z|$.



7.1 The transfer function for the state variable representation $\dot{X} = AX + BU$, $Y = CX + DU$, is given by

- (a) $D + C(sI - A)^{-1} B$
 (b) $B(sI - A)^{-1} C + D$
 (c) $D(sI - A)^{-1} B + C$
 (d) $C(sI - A)^{-1} D + B$

[1993 : 1 Mark]

7.2 Consider a second order system whose state space representation is of the form $\dot{X} = AX + BU$.

If $x_1(t) = x_2(t)$, then system is

- (a) controllable (b) uncontrollable
 (c) observable (d) unstable

[1993 : 1 Mark]

7.3 The matrix of any state space equations for the transfer function $C(s)/R(s)$ of the system, shown below in the figure is

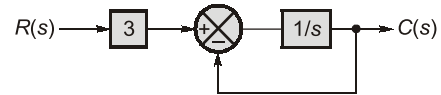

- (a) $\begin{bmatrix} -1 & 0 \\ 0 & 1 \end{bmatrix}$ (b) $\begin{bmatrix} 1 & 0 \\ 0 & -1 \end{bmatrix}$

- (c) $[-1]$ (d) $[3]$

[1994 : 1 Mark]

7.4 The eigen-values of the matrix $\begin{bmatrix} a & 1 \\ a & 1 \end{bmatrix}$ are

- (a) $(a + 1), 0$ (b) $a, 0$
 (c) $(a - 1), 0$ (d) $0, 0$

[1994 : 1 Mark]

Answers State Variable Analysis

7.1 (a) 7.2 (b) 7.3 (c) 7.4 (a)

Explanations State Variable Analysis

7.1 (a)

$$\text{T.F.} = C[sI - A]^{-1} B + D$$

7.2 (b)

$$\text{Let, } \begin{bmatrix} \dot{x}_1 \\ \dot{x}_2 \end{bmatrix} = \begin{bmatrix} a & b \\ c & d \end{bmatrix} \begin{bmatrix} x_1(t) \\ x_2(t) \end{bmatrix} + \begin{bmatrix} e \\ f \end{bmatrix} u(t)$$

$$[B] = \begin{bmatrix} e \\ f \end{bmatrix}, \quad [AB] = \begin{bmatrix} ae + bf \\ ce + df \end{bmatrix}$$

Since, $x_1(t) = x_2(t)$ and $\dot{x}_1(t) = \dot{x}_2(t)$

$$\Rightarrow e = f \text{ and } a + b = c + d$$

$$\therefore |Q_d| = |B \ AB| = \begin{vmatrix} e & ae + bf \\ f & ce + df \end{vmatrix} = 0$$

\Rightarrow Uncontrollable.

7.3 (c)

$$\text{T.F.} = \frac{3}{s+1}$$

\Rightarrow Pole = -1
 \therefore Eigen value of 'A' = -1
 \Rightarrow Option (c) is correct.

7.4 (a)

Characteristic equation:

$$|sI - A| = 0$$

$$\begin{vmatrix} s-a & -1 \\ -a & s-1 \end{vmatrix} = 0$$

$$(s-a)(s-1) - a = 0$$

\therefore Eigen values, $s = 0, (a + 1)$

Electrical & Electronic Measurements

UNIT VI

CONTENTS

1. Characteristics of Instruments and Measurement Systems 42
2. Galvanometers, Voltmeters and Ammeters 43
3. Measurement of Resistance and Potentiometers 44
4. Measurement of Energy and Power 45
5. CRO and Electronic Measurements 46

1

Characteristics of Instruments and Measurement Systems

1.1 A precise measurement guarantees accuracy of the measured quantity. (True/False).

[1994 : 1 Mark]

Answers Characteristics of Instruments and Measurement Systems

1.1 (Sol.)

Explanations Characteristics of Instruments and Measurement Systems

1.1 Sol.

Preciseness means repeatability of readings it does not guarantees the accuracy.



2

Galvanometers, Voltmeters and Ammeters

- 2.1 The current $i(t)$ passing through $10\ \Omega$ resistor as shown in the Fig. (i) as a waveform as shown in Fig. (ii). Then the reading of the DC voltmeter is connected across $10\ \Omega$ resistor is

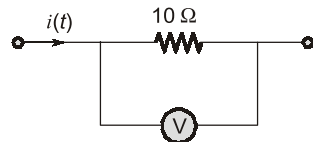

D.C. Voltmeter
Fig. (i)

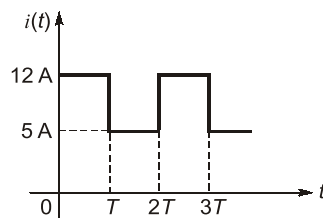

Fig. (ii)

[1991 : 1 Mark]

- 2.2 An unshielded moving iron voltmeter is used to measure the voltage in an ac circuit. If a stray DC magnetic field having a component along the axis of the meter coil appears, the meter reading would be

- (a) unaffected
(b) decreased
(c) increased
(d) either decreased or increased depending on the direction of the DC field

[1992 : 1 Mark]

- 2.3 A metal strain gauge has factor of two. Its nominal resistance is 120 ohms. It undergoes a strain of 10^{-5} , the value of change of resistance in response to the strain is

- (a) 240 ohms (b) 2×10^{-5} ohms
(c) 2.4×10^{-3} ohms (d) 1.2×10^{-3} ohms

[1993 : 1 Mark]

- 2.4 A 0-10 mA PMMC ammeter reads 4 mA in a circuit. Its bottom control spring snaps suddenly. The meter will now read nearly

- (a) 10 mA (b) 8 mA
(c) 2 mA (d) zero

[1994 : 1 Mark]

Answers Galvanometers, Voltmeters and Ammeters

- 2.1 (85) 2.2 (d) 2.3 (c) 2.4 (d)

Explanations Galvanometers, Voltmeters and Ammeters

2.1 Sol.

The voltmeter will read average value,

$$I_{av} = \left(\frac{12+5}{2} \right) \text{A}$$

$$V = I_{av} \times 10\ \Omega = \left(\frac{12+5}{2} \right) \times 10 = 85$$

2.2 (d)

Since, magnetic field is a vector quantity, direction is to be specified.

2.3 (c)

$$G = \frac{\Delta R / R}{\Delta l / l}$$

$$\Rightarrow \frac{\Delta R}{R} = 2 \times 10^{-5}$$

$$\Delta R = 120 \times 2 \times 10^{-5}\ \Omega \\ = 2.4 \times 10^{-3}\ \Omega$$

2.4 (d)

The current through coil will be zero, because in PMMC type instruments control spring is connected in series with the moving coil.

3

Measurement of Resistance and Potentiometers

- 3.1 In DC potentiometer measurements, a second reading is often taken after reversing the polarities of the DC supply and the unknown voltage, and the average of the two readings is taken. This is done with a view to eliminate the effects of
- (a) ripples in the DC supply
 - (b) stray magnetic fields
 - (c) stray thermal emf's
 - (d) erroneous standardization

[1992 : 1 Mark]

- 3.2 A DC potentiometer is designed to measure up to 2 V with a slide wire of 800 mm. A standard cell of emf 1.18 V obtains balance at 600 mm. A test cell is seen to obtain balance at 680 mm. The emf of the test cell is
- (a) 1.00 V
 - (b) 1.34 V
 - (c) 1.50 V
 - (d) 1.70 V

[1994 : 2 Marks]

Answers Measurement of Resistance and Potentiometers

- 3.1 (c) 3.2 (b)

Explanations Measurement of Resistance and Potentiometers

3.2 (b)

∴ Balance at 600 mm is corresponding to an emf of 1.18 V.

∴ Balance at 680 mm is corresponding to an emf

$$\text{of } \frac{1.18}{600} \times 680 \simeq 1.34 \text{ V.}$$



4

Measurement of Energy and Power

- 4.1 The voltage phasor of a circuit is $10\angle 15^\circ$ V and the current phasor is $2\angle -45^\circ$ A. The active and the reactive powers in the circuit are
- (a) 10 W and 17.32 VAR
 - (b) 5 W and 8.66 VAR
 - (c) 20 W and 60 VAR
 - (d) $20\sqrt{2}$ W and $10\sqrt{2}$ VAR

[1994 : 2 Marks]

Answers Measurement of Energy and Power

4.1 (a)

Explanations Measurement of Energy and Power

4.1 (a)

$$\begin{aligned}\text{Complex power} &= VI^* \\ &= 10\angle 15^\circ \times 2\angle 45^\circ = 20\angle 60^\circ \\ &= (10 + j10\sqrt{3}) \\ &= (10 + j17.32) = P + jQ \\ \Rightarrow P &= 10 \text{ W and } Q = 17.32 \text{ VAR}\end{aligned}$$



- 5.1 A lissajous pattern, as shown in the figure below, is observed on the screen of a CRO when voltages of frequencies f_x and f_y are applied to be x and y plates respectively. $f_x : f_y$ is then equal to

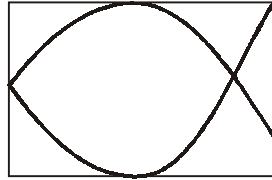

- (a) 3 : 2 (b) 1 : 2
(c) 2 : 3 (d) 2 : 1

[1994 : 1 Mark]

Answers CRO and Electronic Measurements

5.1 (c)

Explanations CRO and Electronic Measurements

5.1 (c)

$$\frac{f_x}{f_y} = \frac{2}{3}$$

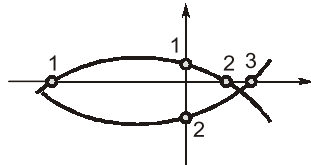

■■■■

Analog Electronics

UNIT VII

CONTENTS

1. Diodes and their Applications 48
2. BJT, FET and their Biasing Circuits 49
3. Operational Amplifiers 50
4. Oscillators and Feedback Amplifiers 52

- 1.1 The figure shows an electronic voltage regulator. The zener diode may be assumed to require a minimum current of 25 mA for satisfactory operations. The value of R required for satisfactory voltage regulation of the circuit is

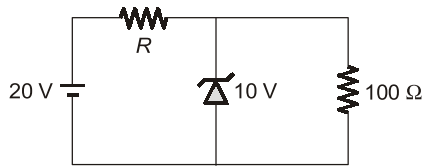

[1991 : 2 Marks]

Answers Diodes and their Applications

1.1 (80)

Explanations Diodes and their Applications

1.1 (80)

Current in $100\ \Omega$ resistance

$$I_{100} = \frac{10\text{ V}}{100\ \Omega} = 100\text{ mA}$$

$$I_2 = 25\text{ mA}$$

Current in resistance R , = $100\text{ mA} + 25\text{ mA}$
= 125 mA

Also, $20 - 10 = 125 \times 10^{-3} \times R$

$$R = \frac{10 \times 1000}{125} = 80\ \Omega$$



BJT, FET and their Biasing Circuits

2.1 The figure shown below, shows a common emitter amplifier. The quiescent collector voltage of the circuit is approximately

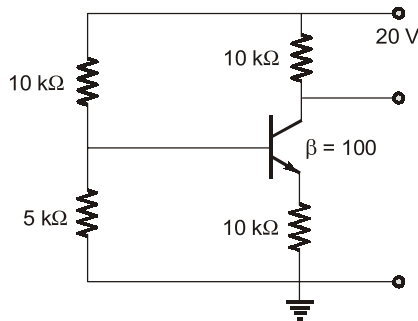

- (a) $\frac{20}{3}$ V (b) 10 V
 (c) 14 V (d) 20 V

[1991 : 1 Mark]

2.2 In the transistor circuit shown in the figure. Collector to ground voltage is +20 V. Which of the following is the probable cause of error?

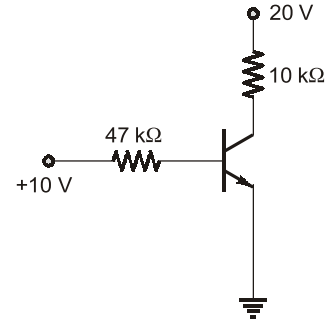

- (a) Collector emitter terminals shorted
 (b) Emitter to ground connection open
 (c) 10 kΩ resistor open
 (d) Collector base terminals shorted

[1994 : 1 Mark]

Answers BJT, FET and their Biasing Circuits

2.1 (c) 2.2 (b)

Explanations BJT, FET and their Biasing Circuits

2.1 (c)

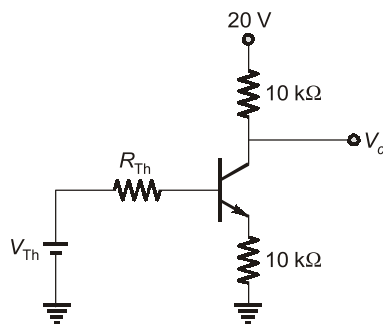

$$V_{Th} = \frac{5}{15} \times 20 \text{ V} = 6.67 \text{ V}$$

$$R_{Th} = \frac{10 \times 5}{10 + 5} = 3.33 \text{ } \Omega$$

$$V_{Th} - I_b R_{Th} - 0.7 - (\beta + 1)I_b \times 10 \text{ k}\Omega = 0$$

$$5.97 = I_b(3.33 + 101 \times 10) \text{ k}\Omega$$

$$I_b = 5.891 \text{ } \mu\text{A}$$

$$I_c = \beta I_b = 0.589 \text{ mA}$$

$$V_c = 20 - 10 \times I_c$$

$$= 14.11 \text{ V} \approx 14 \text{ V}$$

2.2 (b)

$$20 - 10 \text{ k} \times I_c = 20$$

$$\Rightarrow I_c = 0 \text{ which gives}$$

$$I_E = I_C = I_B = 0$$

That is only possible when emitter connection is open. In other cases there will be base current.

- 3.1 An ideal op-amp is used to make an inverting amplifier. The two input terminals of the op-amp are at the same potential because
- the two input terminals are directly shorted internally.
 - the input impedance of the op-amp is infinity.
 - the open-loop gain of the op-amp is infinity.
 - CMRR is infinity.

[1992 : 1 Mark]

- 3.2 The circuit shown in the figure is excited by the input wave form shown. Sketch the wave form of the output. Assume all the components are ideal.

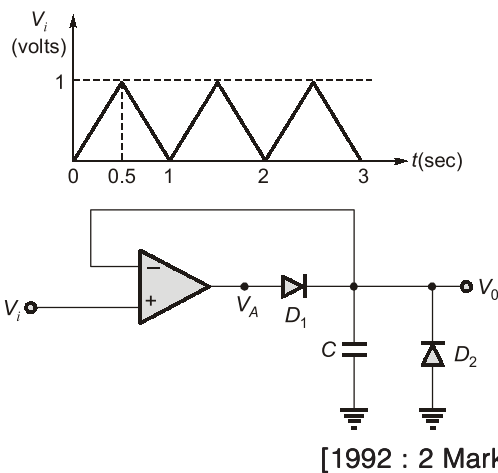

[1992 : 2 Marks]

- 3.3 Given figure, shows a non-inverting op-amp summer with $V_1 = 2\text{ V}$ and $V_2 = -1\text{ V}$ the output voltage $V_0 =$ _____.

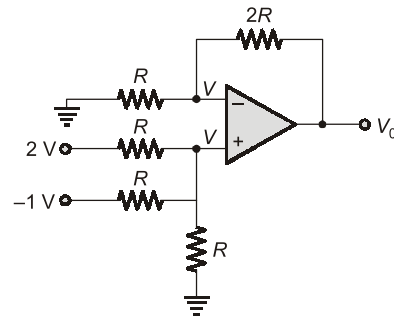

[1994 : 1 Mark]

Answers Operational Amplifiers

3.1 (c, d) 3.2 (Sol.) 3.3 (1)

Explanations Operational Amplifiers

3.2 Sol.

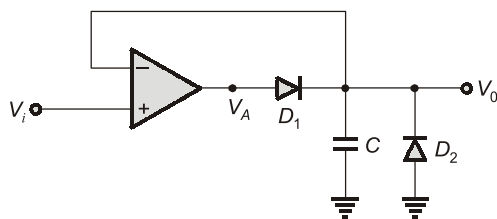

For $0 < t < 0.5\text{ s}$
Capacitor get charged upto 1 volt. D_1 is forward bias and D_2 is reversed bias.

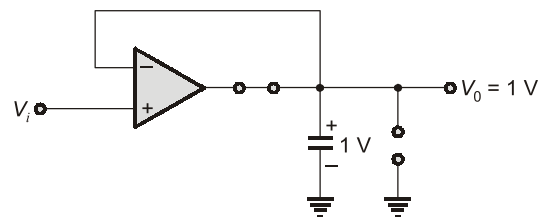

There is no discharging path provided for this capacitor. It will remain charged with 1 V.

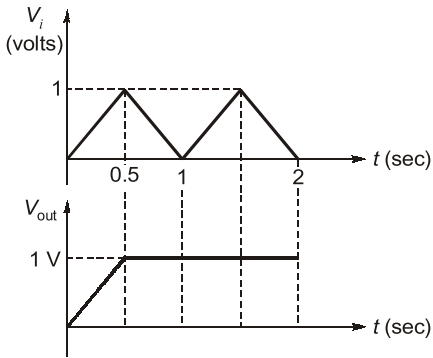
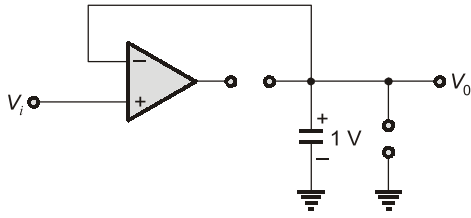

3.3 (1)

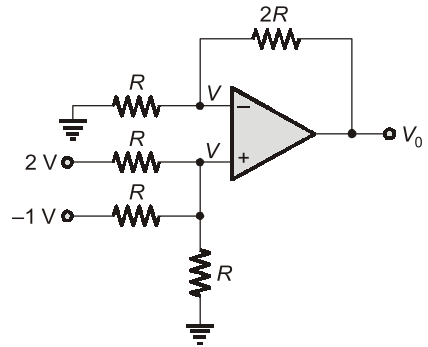

$$\frac{2 - V}{R} + \frac{-1 - V}{R} = \frac{V}{R}$$

$$\Rightarrow V = \frac{1}{3} \text{ Volts}$$

$$\frac{0 - V}{R} = \frac{V - V_0}{2R}$$

$$V_0 = 3V = 1 \text{ Volt}$$



- 4.1 In a common emitter amplifier, the unbypassed emitter resistance provides
- voltage-shunt feedback
 - current-series feedback
 - negative-voltage feedback
 - positive-current feedback

[1992 : 1 Mark]

- 4.2 A Wein bridge oscillator is shown in figure. Which of the following statements are true, if 'f' is the frequency of oscillation?

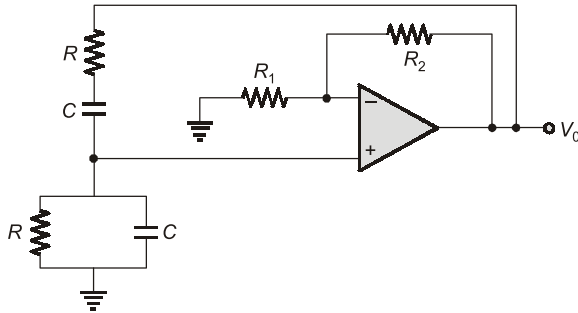

- For $R = 1 \text{ k}\Omega$, $C = \frac{1}{2\pi} \mu\text{F}$, $f = 1 \text{ kHz}$
- For $R = 3 \text{ k}\Omega$, $C = \frac{1}{18\pi} \mu\text{F}$, $f = 3 \text{ kHz}$
- The gain of the op-amp stage should be less than two for proper operation.
- The gain of op-amp should be three for proper operation.

[1993 : 1 Mark]

- 4.3 Given figure shows a two stage small signal transistor feedback amplifier. Match the defective component (listed on the left hand side below) with its probable effect on the circuit (listed on the right hand side).

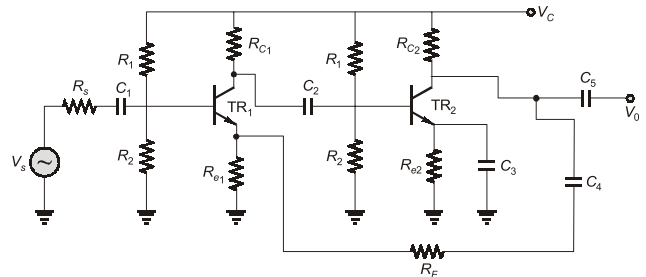

List-I

- Capacitor C_1 is open
- Capacitor C_3 is open
- Capacitor C_4 is open
- R_{C2} is shorted

List-II

- All DC voltages normal, V_0 increase marginally.
- Collector of TR_2 at V_{CC} , $V_0 = 0$.
- All DC voltages normal, gain of 2nd stage decrease V_0 decrease.
- All DC voltage normal, $V_0 = 0$.
- All DC voltage normal, overall gain of the amplifier increases, V_0 increase.
- No change

[1994 : 1 Mark]

- 4.4 A practical RC sinusoidal oscillator is built using a positive feedback amplifier with a closed loop gain slightly less than unity. (True/False)

[1994 : 1 Mark]



Answers Oscillators and Feedback Amplifiers

4.1 (b) 4.2 (a,b,d) 4.3 (Sol.) 4.4 (F)

Explanations Oscillators and Feedback Amplifiers

4.3 Sol.

$A \rightarrow S, B \rightarrow R, C \rightarrow T, D \rightarrow Q.$

4.4 Sol.

False.



Digital Electronics

UNIT VIII

CONTENTS

1. A/D and D/A Converters 55
2. Microprocessors 56

1

A/D and D/A Converters

1.1 A 10 bit A/D converter is used to digitize an analog signal in the 0 to 5 V range. The maximum peak to peak ripple voltage that can be allowed in the DC supply voltage is

- (a) nearly 100 mV (b) nearly 50 mV
(c) nearly 25 mV (d) nearly 5 mV

[1993 : 1 Mark]

1.2 The number of comparisons carried out in a 4-bit flash-type A/D converter is

- (a) 16 (b) 15
(c) 4 (d) 3 [1994 : 1 Mark]

Answers A/D and D/A Converters

1.1 (d) 1.2 (b)

Explanations A/D and D/A Converters

1.1 (d)

If the ripple voltage is more than the resolution, it will go to next level.

$$\text{Resolution} = \frac{V}{2^n} = \frac{5}{2^{10}} \simeq 5 \text{ mV}$$

1.2 (b)

Number of comparators
 $= 2^N - 1 = 2^4 - 1 = 15$



- 2.1 If the *HLT* instruction of a 8085 microprocessor is executed
- (a) the microprocessor is disconnected from the system bus till the reset is pressed.
 - (b) the microprocessor enters into a halt state and the buses are tri-stated.
 - (c) the microprocessor halts execution of the program and returns to monitor.
 - (d) the microprocessor reloads the program from the locations 0024 and 0025H.

[1992 : 1 Mark]

- 2.2 Three devices *A*, *B* and *C* have to be connected to a 8085 microprocessor. Device *A* has highest priority and device *C* has the lowest priority. In this context which of the statements are correct?
- (a) *A* uses TRAP, *B* uses RST 5.5 and *C* uses RST6.5.
 - (b) *A* uses RST 7.5, *B* uses RST 6.5 and *C* uses RST 5.5.

- (c) *A* uses RST 5.5, *B* uses RST 6.5 and *C* uses RST 7.5.
- (d) *A* uses RST 5.5, *B* uses RST 6.5 and *C* uses TRAP.

[1993 : 1 Mark]

- 2.3 The contents of the accumulator in an 8085 microprocessor is altered after the execution of the instruction

- (a) *CMP C* (b) *CPI 3A*
- (c) *ANI 5C* (d) *ORA A*

[1994 : 1 Mark]

- 2.4 The stack pointer of a microprocessor is at A001. At the end of execution of following instructions, the value of stack pointer is _____

```
PUSH   PSW
XTHL
PUSH   D
JMP    FC70H
```

[1994 : 2 Marks]

Answers Microprocessors

2.1 (b) 2.2 (b) 2.3 (c) 2.4 (Sol.)

Explanations Microprocessors

2.2 (b)

Priority order.
TRAP > RST 7.5 > RST 6.5 > RST 5.5 > INTR.

2.3 (c)

Compare instruction does not alter the content accumulator. Similarly self OR operation will also not alter the content of accumulator.

2.4 Sol.

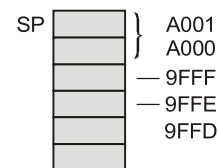

```
A 0 0 1 H
  0 4 H
  ---
 9 F F 0 H
```

Power Electronics

UNIT IX

CONTENTS

1. Power Semiconductor Devices and
Commutation Techniques 58
2. Phase Controlled Rectifiers 59
3. Choppers 60
4. Inverters 61
5. Miscellaneous 62

Power Semiconductor Devices and Commutation Techniques

1.1 In the circuit of figure the switch 'S' is closed at $t = 0$ with $i_L(0) = 0$ and $v_C(0) = 0$. In the steady state v_C equals

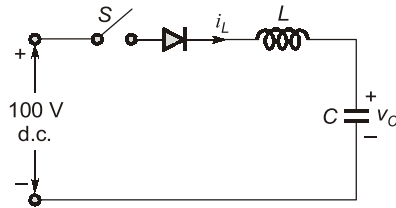

- (a) 200 V
- (b) 100 V
- (c) zero
- (d) -100 V

[1992 : 1 Mark]

1.2 The thermal resistance between the body of a power semiconductor device and the ambient is expressed as

- (a) voltage across the device divided by current through the device.
- (b) average power dissipated in the device divided by the square of the rms current in the device.

- (c) average power dissipated in the device divided by the temperature difference from body to ambient.
- (d) temperature difference from body to ambient divided by average power dissipated in the device.

[1993 : 1 Mark]

1.3 A triac can be triggered by a gate pulse of _____ polarity.

[1994 : 1 Mark]

1.4 A switched mode power supply operating at 20 kHz to 100 kHz range uses as the main switching element.

- (a) Thyristor
- (b) MOSFET
- (c) Triac
- (d) UJT

[1994 : 1 Mark]

Answers Power Semiconductor Devices & Commutation Techniques

1.1 (a) 1.2 (d) 1.3 (+ve, -ve) 1.4 (b)

Explanations Power Semiconductor Devices & Commutation Techniques

1.1 (a)

Voltage across capacitor,

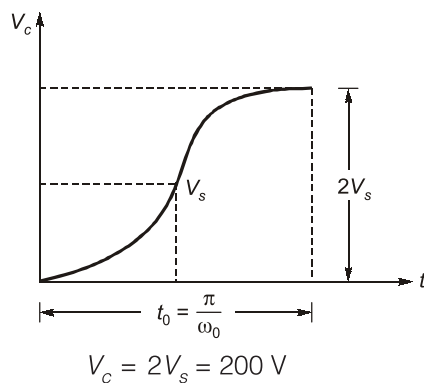

1.3 Sol.

Both positive and negative.

1.4 (b)

MOSFET is used for this frequency range.



2

Phase Controlled Rectifiers

2.1 In the circuit shown in the figure, L is large and the average value of 'i' is 100 A. The thyristor is gated in the _____ half cycle of 'e' at a delay angle is equal to _____

$$e(t) = 200\sqrt{2} \sin 314t.$$

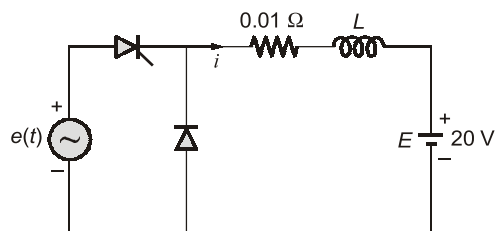

[1992 : 1 Mark]

2.2 Referring to the figure, the type of load is

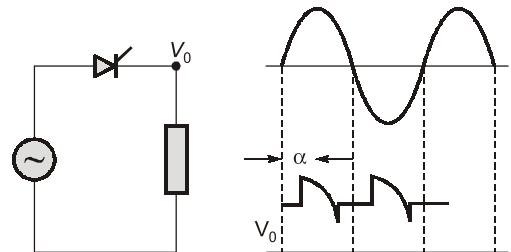

- (a) inductive load
- (b) resistive load
- (c) DC motor
- (d) capacitive load

[1994 : 1 Mark]

2.3 The output voltage of a six-pulse double star rectifier is the same as that of a three-phase half wave rectifier. (True/False).

[1994 : 1 Mark]

Answers Phase Controlled Rectifiers

2.1 (4.054°) 2.2 (c) 2.3 (F)

Explanations Phase Controlled Rectifiers

2.1 Sol.

$$V_o = I_o R + E$$

$$\frac{V_m}{2\pi} (1 + \cos \alpha) = I_o R + E$$

$$\frac{220\sqrt{2}}{2\pi} (1 + \cos \alpha) = 100 \times 0.01 + 20$$

$$1 + \cos \alpha = 0.4241$$

$$\alpha = 125.16^\circ$$

Triggering angle

$$\theta_1 = \sin^{-1} \left(\frac{E}{V_m} \right) = \sin^{-1} \left(\frac{20}{200 \times \sqrt{2}} \right) = 4.054^\circ$$

2.2 (c)

RLE load with discontinuous conduction.

2.3 Sol.

(False)



- 3.1 A chopper operating at a fixed frequency is feeding an $R-L$ load. As the duty ratio of the chopper is increased from 25% to 75%, the ripple in the load current
- (a) remains constant.
 - (b) decreases, reaches a minimum at 50% duty ratio and then increases.
 - (c) increase, reaches a maximum at 50% duty ratio and then decreases.
 - (d) keeps on increasing as the duty ratio is increased.

[1993 : 1 Mark]

Answers Choppers

3.1 (c)

Explanations Choppers

3.1 (c)

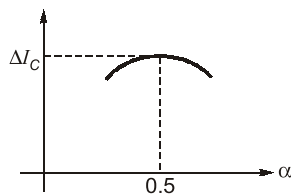

- 4.1 When a line commutated converter operates in the inverter mode?
- (a) It draws both real and reactive power from the AC supply.
 - (b) It delivers both real and reactive power to the AC supply.
 - (c) It delivers real power to the AC supply.
 - (d) It draws reactive power from the AC supply.
- [1993 : 1 Mark]
- 4.2 A line-commutated inverter changes DC voltage to AC voltage. (True/False)
- [1994 : 1 Mark]

Answers Inverters

4.1 (c) 4.2 (T)

Explanations Inverters

4.2 Sol.

(True).



5.1 Match the items on the List-I with List-II.

- | List-I | List-II |
|------------------------|----------------------|
| A. Commutation | P. Resistive load |
| B. V-Curves | Q. Inductive load |
| C. Free wheeling diode | R. Capacitance load |
| D. Overlap | S. Inter pole |
| | T. Source inductance |
| | U. Synchronous motor |
- [1994 : 1 Mark]

5.2 Thyristor circuits that directly convert polyphase ac voltages from one frequency to another frequency are called _____. [1994 : 1 Mark]

Answers Miscellaneous

5.1 (Sol.) 5.2 (Sol.)

Explanations Miscellaneous

5.1 Sol.

- A — S
 B — U
 C — Q
 D — T

5.2 Sol.

Thyristor circuits that directly convert polyphase ac voltages from one frequency to another frequency are called *cycloconverters*.



Electromagnetic Theory

UNIT

X

CONTENTS

1. Electrostatic Fields 64
2. Magnetostatic Fields 65

1.1 An electrostatic potential is given by $\phi = 2x\sqrt{y}$ volts in the rectangular co-ordinate system. The magnitude of the electric field at $x = 1$ m, $y = 1$ m is _____ V/m. [1992 : 1 Mark]

1.2 Which of the following equations represents the Gauss' law in a homogenous isotropic medium?

(a) $\iint \vec{D} \cdot d\vec{S} = \iiint \rho dV$ (b) $\nabla \times \vec{H} = \vec{D}$

(c) $\nabla \cdot \vec{J} + \rho = 0$ (d) $\nabla \cdot \vec{E} = \frac{\rho}{\epsilon}$ [1992 : 1 Mark]

1.3 In electrostatic field, $\nabla \times \vec{E} \equiv 0$ (True/False).

[1994 : 1 Mark]

Answers Electrostatic Fields

1.1 (2.24) 1.2 (a) 1.3 (T)

Explanations Electrostatic Fields

1.1 Sol.

Electrostatic potential, $\phi = 2x\sqrt{y}$

$$\therefore \vec{E} = -\text{grad}(\phi) = -\nabla\phi$$

$$\therefore \vec{E} = -\left[\hat{a}_x \frac{\partial}{\partial x}(2x\sqrt{y}) + \hat{a}_y \frac{\partial}{\partial y}(2x\sqrt{y})\right]$$

$$\vec{E} = -\hat{a}_x 2\sqrt{y} - \hat{a}_y \frac{x}{\sqrt{y}}$$

Now, at $x = 1$ m and $y = 1$ m

$$\vec{E} = -2\hat{a}_x - \hat{a}_y$$

Magnitude of \vec{E}

$$|\vec{E}| = \sqrt{2^2 + 1^2} = \sqrt{5} = 2.24 \text{ V/m}$$

1.2 (a)

Gauss Law: The electric flux passing through any closed surface is equal to the total charge in the volume enclosed by the surface i.e. $\iint \vec{D} \cdot d\vec{S} = \iiint \rho_v dV$.

1.3 Sol. (True)

By stroke's theorem,

$$\int_s (\nabla \times \vec{E}) \cdot d\vec{s} = \oint_c \vec{E} \cdot d\vec{l}$$

which represents the potential difference around a closed path, C which is zero in electrostatic field.

Hence, $\nabla \times \vec{E} = 0$ i.e. electromagnetic fields are conservative in nature.



2

Magnetostatic Fields

2.1 The line integral of the vector potential A around the boundary of a surface S represents

- (a) flux through the surface S
- (b) flux density in the surface S
- (c) magnetic density
- (d) current density

[1993 : 1 Mark]

2.2 Static magnetic fields induce currents in closed conducting loops. (True/False)

[1994 : 1 Mark]

Answers Magnetostatic Fields

2.1 (a) 2.2 (F)

Explanations Magnetostatic Fields

2.1 (a)

Using Stoke's theorem,

$$\oint \vec{A} \cdot d\vec{L} = \int_s (\nabla \times \vec{A}) \cdot d\vec{s}$$

$\therefore \vec{A}$ is vector magnetic potential

$$\Rightarrow \nabla \times \vec{A} = \text{curl}(\vec{A})$$

= Magnetic flux density \vec{B}

$$\Rightarrow \int_s (\nabla \times \vec{A}) \cdot d\vec{s} = \int_s \vec{B} \cdot d\vec{s}$$

= Flux through the surface S .

2.2 Sol. (False)

According to Faraday's law: induced voltage

$\propto \frac{d\phi}{dt}$ i.e. only time varying fields induce voltage

and hence responsible for production of induced currents in closed loops.



Engineering Mathematics

UNIT XI

CONTENTS

1. Linear Algebra 66

1.1 A 5×7 matrix has all its entries equal to -1 . Then the rank of a matrix is

- (a) 7 (b) 5
(c) 1 (d) 0

[1994 : 1 Mark]

1.2 The eigen values of the matrix $\begin{bmatrix} a & 1 \\ a & 1 \end{bmatrix}$ are

- (a) $(a+1), 0$ (b) $a, 0$
(c) $(a-1), 0$ (d) $0, 0$

[1994 : 1 Mark]

1.3 The number of linearly independent solutions of the system of equations

$$\begin{bmatrix} 1 & 0 & 2 \\ 1 & -1 & 0 \\ 2 & -2 & 0 \end{bmatrix} \begin{bmatrix} x_1 \\ x_2 \\ x_3 \end{bmatrix} = 0 \text{ is equal to}$$

- (a) 1 (b) 2
(c) 3 (d) 0

[1994 : 2 Marks]

Answers Linear Algebra

1.1 (c) 1.2 (a) 1.3 (b)

Explanations Linear Algebra

1.1 (c)

$$A = \begin{bmatrix} -1 & -1 & -1 & -1 & -1 & -1 & -1 \\ -1 & -1 & -1 & -1 & -1 & -1 & -1 \\ -1 & -1 & -1 & -1 & -1 & -1 & -1 \\ -1 & -1 & -1 & -1 & -1 & -1 & -1 \\ -1 & -1 & -1 & -1 & -1 & -1 & -1 \end{bmatrix}$$

$$\simeq \begin{bmatrix} -1 & -1 & -1 & -1 & -1 & -1 & -1 \\ 0 & 0 & 0 & 0 & 0 & 0 & 0 \\ 0 & 0 & 0 & 0 & 0 & 0 & 0 \\ 0 & 0 & 0 & 0 & 0 & 0 & 0 \\ 0 & 0 & 0 & 0 & 0 & 0 & 0 \end{bmatrix}$$

$$R_2 - R_1, R_3 - R_1, R_4 - R_1, R_5 - R_1$$

number of non-zero rows = 1

\therefore rank = 1

1.2 (a)

Ch. equation is $|A - \lambda I| = 0$

$$\begin{vmatrix} a-\lambda & 1 \\ a & 1-\lambda \end{vmatrix} = 0$$

$$(a-\lambda)(1-\lambda) - a = 0$$

$$a - a\lambda - \lambda + \lambda^2 - a = 0$$

$$\lambda^2 - (a+1)\lambda = 0$$

$$\lambda = 0, \lambda = a+1$$

1.3 (b)

$$\begin{bmatrix} 1 & 0 & 2 \\ 1 & -1 & 0 \\ 2 & -2 & 0 \end{bmatrix} \begin{bmatrix} x_1 \\ x_2 \\ x_3 \end{bmatrix} = \begin{bmatrix} 0 \\ 0 \\ 0 \end{bmatrix}$$

$$R_2 - R_1, R_3 - 2R_1$$

$$\begin{bmatrix} 1 & 0 & 2 \\ 0 & -1 & -2 \\ 0 & -2 & -4 \end{bmatrix} \begin{bmatrix} x_1 \\ x_2 \\ x_3 \end{bmatrix} = \begin{bmatrix} 0 \\ 0 \\ 0 \end{bmatrix}$$

$$R_3 - 2R_2$$

$$\begin{bmatrix} 1 & 0 & 2 \\ 0 & -1 & -2 \\ 0 & 0 & 0 \end{bmatrix} \begin{bmatrix} x_1 \\ x_2 \\ x_3 \end{bmatrix} = \begin{bmatrix} 0 \\ 0 \\ 0 \end{bmatrix}$$

Rank = 2 number of variables = 3

Nullity = number of linearly independent solutions = 2

